

FEATURES

- 0...±5, 0...±10, 0...10 "H₂O differential/gage
- 0.5...4.5 V ratiometric output
- Precision ASIC conditioning
- Temperature compensated

GENERAL DESCRIPTION

The amplified ASDXL series offers a high level output (4.0 V or ±2.0 V span respectively) on a very cost-effective basis. This family is fully calibrated and temperature compensated using an on-board ASIC. The sensors are intended for use with non-corrosive, non-ionic working fluids such as air and dry gases.

The ASDXL10D44R device is available to measure gage pressure from 0...10 "H₂O and offers 4 V span.

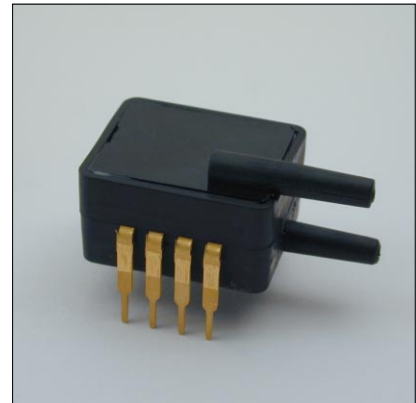

APPLICATIONS

- Medical instrumentation
- HVAC controls
- Pneumatic controls

The ASDXL...4D devices are available to measure differential pressures from 0...±5 "H₂O (ASDXL05D44D) to 0...±10 "H₂O (ASDXL10D44D) and offer ±2.0 V span. Differential devices allow application of pressure to either side of the sensing diaphragm and can be used for gage or differential measurements.

All ASDXL devices are accurate to within ±2.5 %FSS. The devices are characterized for operation from a single 5 V supply. The sensor is designed and manufactured according to standards laid down in ISO9001.

ELECTRICAL CONNECTION

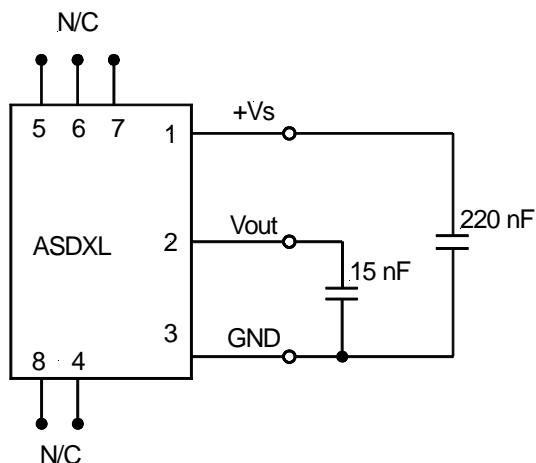

Note: Capacitor 220 nF required between +Vs and GND and 15 nF between Vout and GND.

It is important to place the capacitors as close to the pins as possible!

Pins 4, 5, 6, 7 and 8 are internal device connections and should not be connected for any reason!

PRESSURE SENSOR CHARACTERISTICS

Maximum ratings

Supply voltage V_s	4.75 V to 5.25 V_{DC} max 6.50 V_{DC}
Output current	
Sink	2 mA
Source	2 mA
Lead temperature (2 - 4 sec.)	250 °C
Common mode pressure	50 psi

Environmental specifications

Temperature ranges	
Compensated	0 to +85 °C
Operating	-20 to +105°C
Storage	-40 to +125 °C
Vibration:	10 g at 20 - 2000 Hz
Shock:	50 g for 11 ms

Caution! The sensor is not reverse polarity protected. Incorrect applications of excitation voltage or ground to the wrong pin can cause electrical failure. Application of supply voltage above the maximum can cause electrical failure.

PRESSURE RANGES SPECIFICATIONS

($V_s = 5.0 V_{DC}$, $T_A = 25^\circ C$)

Part number	Pressure range		Burst pressure ¹		Sensitivity (typ.)	
ASDXL05D44D	0...±5	"H ₂ O	3	psi	0.400	V/"H ₂ O
ASDXL10D44D	0...±10		3		0.200	
ASDXL10D44R	0...10		3		0.400	

Specification notes:

1. If maximum burst pressure is exceeded, even momentarily, the package may leak or burst, or the pressure sensing die may fracture.
2. Full Scale Span (FSS) is the algebraic difference between the output signal for the highest and lowest specified pressure. Span is ratiometric to the supply voltage.
3. Total accuracy is the combined error from offset and span calibration, linearity, pressure hysteresis, and temperature effects. Linearity is the measured deviation based on a straight line. Hysteresis is the maximum output difference at any point within the operating pressure range for increasing and decreasing pressure. Calibration errors include the deviation of offset and full scale from nominal values.
4. Delay time between sampling and signal change at the output.
5. The smallest change in the output voltage, given any change in pressure.

PERFORMANCE CHARACTERISTICS

0.5 to 4.5 V ratiometric output ($V_S = 5.0 V_{DC}$, $T_A = 25^\circ C$)

ASDXL...D44D

Characteristics	Min.	Typ.	Max.	Units
Zero pressure offset	2.40	2.50	2.60	V
Full scale span (FSS) ²		4.00		
Output at max. specified pressure at min. specified pressure	4.40 0.40	4.50 0.50	4.60 0.60	
Total accuracy (0 to 85 °C) ³			±2.5	%FSS
Sample rate	100			Hz
Response delay ⁴	2.73		14.11	ms
Quantization step ⁵		3		mV
Current consumption		6		mA

ASDXL10D44R

Characteristics	Min.	Typ.	Max.	Units
Zero pressure offset	0.40	0.50	0.60	V
Full scale span (FSS) ²		4.00		
Full scale output	4.40	4.50	4.60	
Total accuracy (0 to 85 °C) ³			±2.5	%FSS
Sample rate	100			Hz
Response delay ⁴	2.73		14.11	ms
Quantization step ⁵		3		mV
Current consumption		6		mA

ELECTRICAL CONNECTION

Note:

Pins 4, 5, 6, 7 and 8 are internal device connections and should not be connected for any reason!

PHYSICAL DIMENSIONS

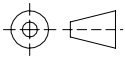
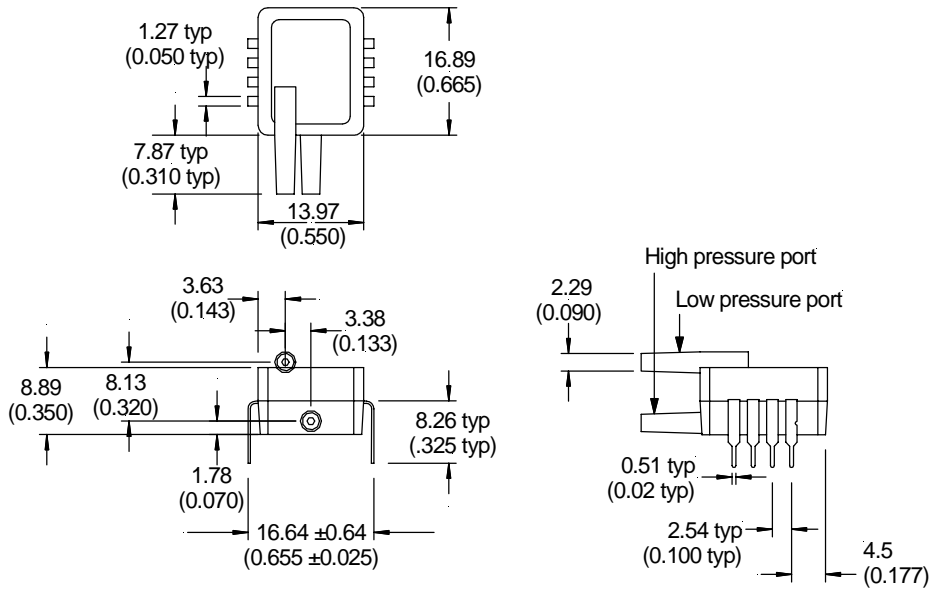

third angle projection

dimensions in mm (inches)

ORDERING INFORMATION

Pressure range	Differential/Gage
0...±5 "H ₂ O	ASDXL05D44D
0...±10 "H ₂ O	ASDXL10D44D
0...10 "H ₂ O	ASDXL10D44R

Other pressure ranges or calibrations are available on request

SenSym and Sensortechinics reserve the right to make changes to any products herein. SenSym and Sensortechinics do not assume any liability arising out of the application or use of any product or circuit described herein, neither does it convey any license under its patent rights nor the rights of others.