



Description of the hygrostat

The humidity measuring element, produced by Galltec under the name Polyga®, consists of several synthetic fabric bands each with 90 individual fibres with a diameter of 0.003mm. A special process gives the fibre hygroscopic properties. The measuring element absorbs and desorbs humidity. The swelling effect, which is predominantly in a lengthways direction, is carried via a suitable lever system to a microswitch with an extremely small switching path. The measuring element reacts quickly and precisely to the change in air humidity. By adjusting the set value control knob, the lever system is engaged so that when the set air humidity is reached the microswitch is activated.

In the case of the hygrostat type HG80-2, a second microswitch is positioned parallel to the first microswitch. After the housing cover has been removed, the second set value can be finely adjusted at the microswitch lever using a screwdriver. The switch point of the second microswitch is connected to the switch point of the first microswitch. The switch distance (neutral zone) can be set from 0% rel. humidity to +15% rel. humidity.

The fan shaped measuring element is protected by a perforated sensor tube and is exposed to the housing. The hygrosats are designed for pressureless systems. The mounting position should be chosen such that condensed water cannot get into the interior of the housing. The preferred mounting position is with the „sensor vertically downwards“ or „sensor horizontal“ (see diagram on the reverse). In the mounting positions described above, a blanking plate in the sensor tube with a 0.8mm diameter hole will prevent water getting in.

Hygrostat HG80Exi
 with a changeover contact
 for intrinsically safe circuits
 with Polyga® humidity measuring element

Hygrostat HG80-2Exi
 with two changeover contacts
 for intrinsically safe circuits
 with Polyga® humidity measuring element
 measuring range 30...100%rh

Note:

*The hygrostat must only be used with approved safety barriers, approved measuring converters or explosion-proof equipment in explosive areas.
 Only for intrinsically safe circuits.*

Technical Data

scale range	30...100%rh
measuring accuracy	
for measuring range > 50%rh	±3.5%rh
for measuring range < 50%rh	±4.0%rh
range of operation	35...95%rh
measuring medium	air, pressureless, non-aggressive
switching difference (microswitch) ref. to 50%rh	approx. 4%rh
switching distance	
between the microswitches for the HG80-2Exi	0...+15%rh
permissible load P	100 mW
max. voltage U ₀	9,0 V
max. current I _K	25 mA
max. induction L _i	< 100 µH
max. capacity C _i	< 10 pF
contact material microswitch	gold
temperature class	T6
permissible ambient temperature	-20...+40 °C
permissible working temperature	0...+40 °C
average temperature coefficient ..	-0,2%/K ref. to 20 °C and 50%rh
adjustment	at average air pressure 430m NN
permissible airspeed	8m/sec
with gauze protection (item no. 20.014)	15m/sec
time constant T ₆₃ at v=2m/sec	120sec
probe length; probe material	220mm; high-grade steel
fixing	slots in the housing base for duct mounting
(item no. 20.009)	console für wall mounting
mounting position	sensor vertically downwards or horizontally
connecting terminals	for conductor cross sections up to 1.5mm ²
cable connection	via twist nipple M20x1.5
electromagnetic compatibility	
resistance to interference	EN 50 082-2
interference emission	EN 50 081-2
housing	ABS light grey
protective system (exterior rotating knob)	IP54
(interior rotating knob)	IP64
measuring element	
..... Polyga®-measuring element, water resistant, washable	
weight	approx. 0,7kg
"subject to technical modifications"	

This information is based on current knowledge and is intended to provide details of our products and their possible applications. It does not, therefore, act as a guarantee of specific properties of the products described or of their suitability for a particular application. It is our experience that the equipment may be used across a broad spectrum of applications under the most varied conditions and loads. We cannot appraise every individual case. Purchasers and/or users are responsible for checking the equipment for suitability for any particular application. Any existing industrial rights of protection must be observed. The perfect quality of our products is guaranteed under our General Conditions of Sale. Issue: February 2009. Subject to modifications.

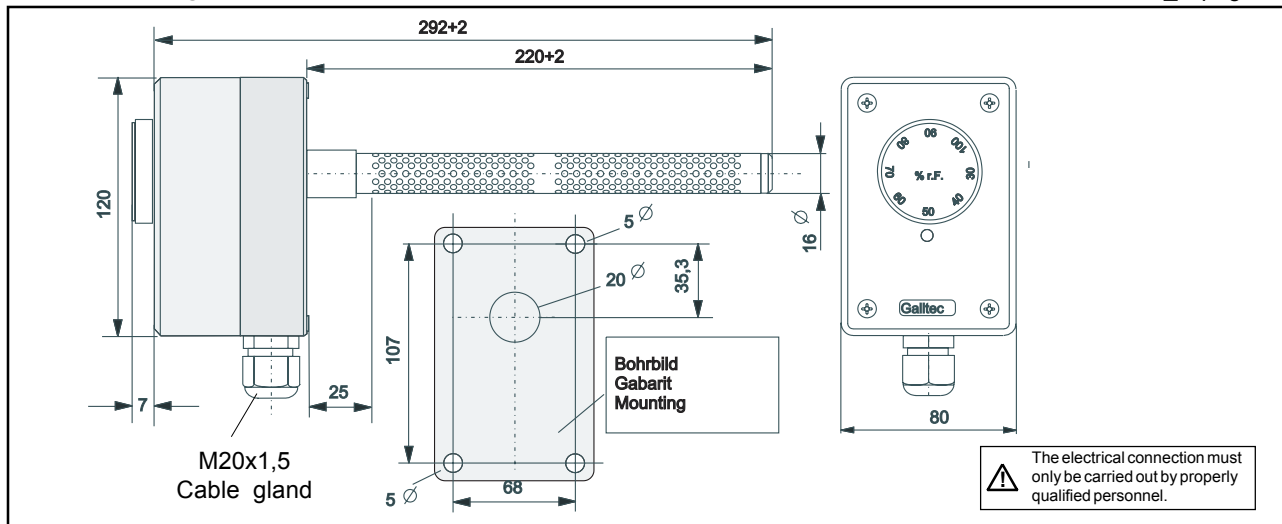

Connection diagram

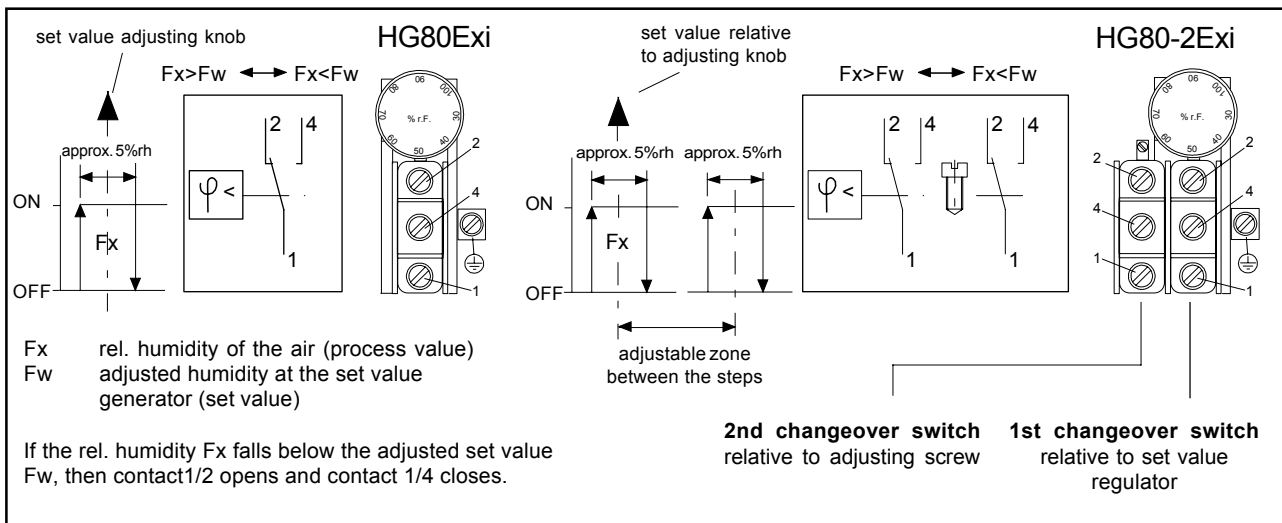

Adjusting the 2nd set value

The hygostats HG80-2(i)Exi are set by the factory such that the 2nd set value is 6% rel. humidity higher than the 1st set value.

The neutral zone (distance between the 1st and 2nd set value) can be adjusted after removing the housing cover using a screwdriver. If turned to the left, the 2nd set value goes up (from 0%rh to +15%rh relative to the 1st set value). The neutral zone can be read using the rotary knob.

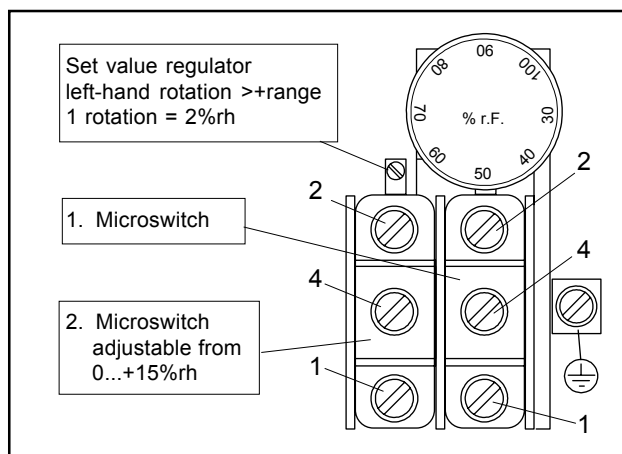

Accessories

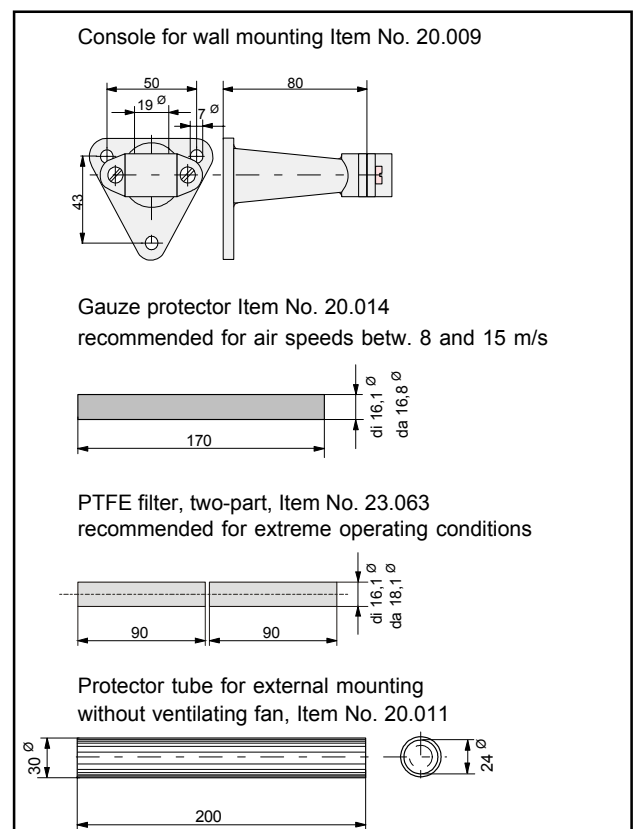

Operating instructions for channel hygrostat HG80Exi and HG80-2Exi

Mounting

- > The hygrostats must not come into direct contact with water (e.g. splashed water when cleaning the climatic chamber etc.)
- > The mounting location should be chosen so that a representative measurement of the air humidity can be guaranteed, i.e. the humidity readings at the mounting location should correspond to those in the room as far as possible.
- > The hygrostat should be exposed to the flow of air.

Operating information:

Note that, with restrictions in the upper range of operation, the possible tolerances (measurement accuracy, switching difference and temperature coefficient) should be observed when adjusting the switch point.

Preferred mounting positions

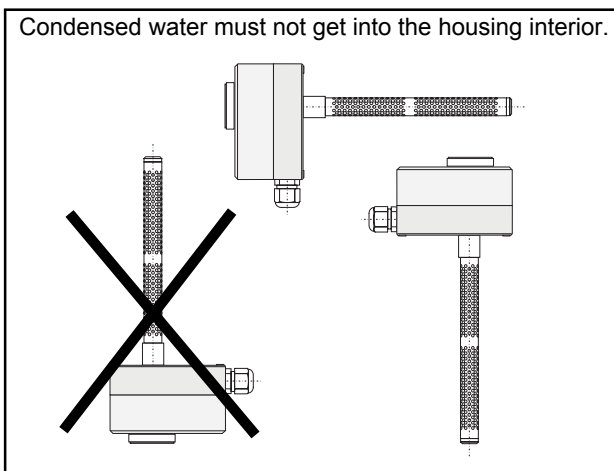

Calibration

Equipment with Galltec hygrometers is correctly set by the factory at a room temperature of 23°C and 50% rel. humidity, relative to the average air pressure of 430m NN.

If, however, subsequent adjustment should be necessary, the following procedure should be observed.

- > Ensure that the ambient humidity and the ambient temperature are constant.
- > If possible, use a psychrometer for checking (no checking equipment with capacitive sensors).
- > Leave the equipment to be checked for at least *1 hour in a constant checking climate*.
- > The adjuster screw is at the end of the sensor - fixed with screw securing lacquer. After removing the lacquer, the adjuster screw can be moved. A right-hand rotation means that the measured value goes down, and with a left-hand rotation the measured value goes up. After calibration, the adjuster screw should again be secured.

NOTE:

Contact with the inner parts or moving the adjuster screw nullifies the guarantee.

Important. The water absorption capacity of the air is influenced, amongst other things, by the temperature. This is a physical law (which can be seen from the hx diagram of Mollier). The higher the air temperature, the greater the volume of water vapour that can be absorbed up to saturation point (100%rh). If a hygrometer is now calibrated at fluctuating air temperature, there is an irregular, non-homogeneous measured medium and there are automatically calibration errors. The table below shows the influence of the air temperature on air humidity. If, for example, calibration occurs at an air temperature of 20 °C and 50%rh, and at a temperature fluctuation of just ± 1 °K, then there will be a humidity fluctuation in the measured medium (air) of $\pm 3.2\%$ rh.

	10°C	20°C	30°C	50°C
10%rh	$\pm 0,7\%$ rh	$\pm 0,6\%$ rh	$\pm 0,6\%$ rh	$\pm 0,5\%$ rh
50%rh	$\pm 3,5\%$ rh	$\pm 3,2\%$ rh	$\pm 3,0\%$ rh	$\pm 2,6\%$ rh
90%rh	$\pm 6,3\%$ rh	$\pm 5,7\%$ rh	$\pm 5,4\%$ rh	$\pm 4,6\%$ rh

Maintenance

The measuring element is maintenance-free in pure ambient air. Aggressive media containing solvent can cause measuring errors and failure, depending on the type and concentration. As with almost all humidity measuring elements, deposits which eventually form a water-repellent film over the sensor are harmful. Such substances are resin aerosols, lacquer aerosols, smoke deposits etc. The water-resistant property of the Galltec measuring elements allows cleaning to be carried out in water. Solvents cannot be used for this purpose. A light-duty detergent is recommended, but any residue should always be washed out thoroughly.

A special process ensures that Galltec sensors have good long-term stability. Regeneration is not necessary, but is also not harmful.