

**FEATURES**

- Ultra-compact size, long life, and high efficiency
- Ideal for use in portable air and gas applications
- Intrinsically safe motors
- Broad media compatibility
- Contamination-free



**WETTED MATERIALS**

Diaphragm: EPDM, FKM or Neoprene  
Valve: Silicone or FKM  
Head: ABS or PPS

**ELECTRICAL**

Voltage (nominal)	4, 5.6, 6, 8.3 or 12.4 V <sub>DC</sub>
Max. power @ nom. voltage	0.4, 1.2, 1.9, 2.3 or 3.2 W
Electrical termination	solder tabs or wire leads

**SPECIFICATIONS**

Max. ambient and media temperature	0 to +50 °C
Weight	
T3CP..., T3EP...	33 g
T3HP...	42 g

# T2-03

## Miniature diaphragm pumps

### PERFORMANCE CHARACTERISTICS

(Standard conditions: 22 °C (70 °F) and 14.7 psia)

Part no.	Max. flow	Max. pressure		Max. vacuum	
		intermittent	continuous	intermittent	continuous
T3CP-1HE-06-1...	3 lpm	450 mbar (6.5 psi)	140 mbar (2 psi)	415 mbar (12.2 inch Hg)	140 mbar (4 inch Hg)
T3CP-1HE-04-1...	2.5 lpm	310 mbar (4.5 psi)		290 mbar (8.6 inch Hg)	
T3CP-1HE-04-2...	1.1 lpm	380 mbar (5.5 psi)		350 mbar (10.4 inch Hg)	
T3EP-1ST-08-1...	2.5 lpm	725 mbar (10.5 psi)		705 mbar (20.8 inch Hg)	
T3EP-1ST-05-3...	1.5 lpm	810 mbar (11.7 psi)		565 mbar (16.7 inch Hg)	
T3HP-1PD-12-1...	2.5 lpm	830 mbar (12 psi)	550 mbar (8 psi)	615 mbar (18 inch Hg)	415 mbar (12.2 inch Hg)

### FLOW CURVES

#### T3CP... (COMPACT)

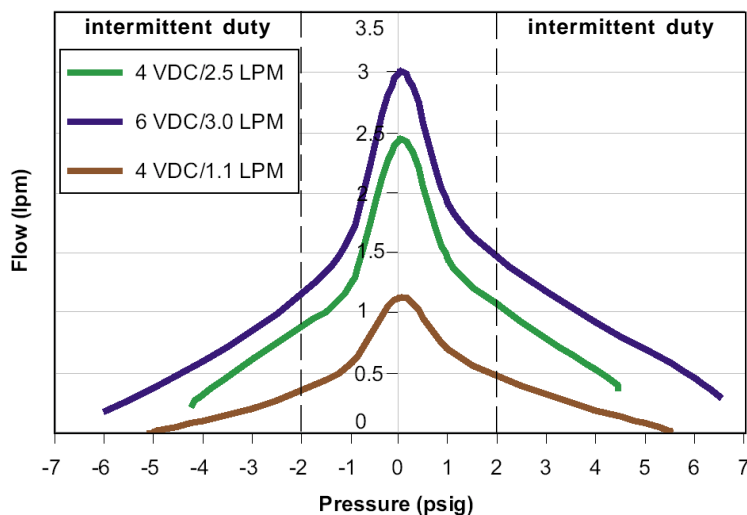

FLOW CURVES (cont.)

T3EP... (E-COMPACT)

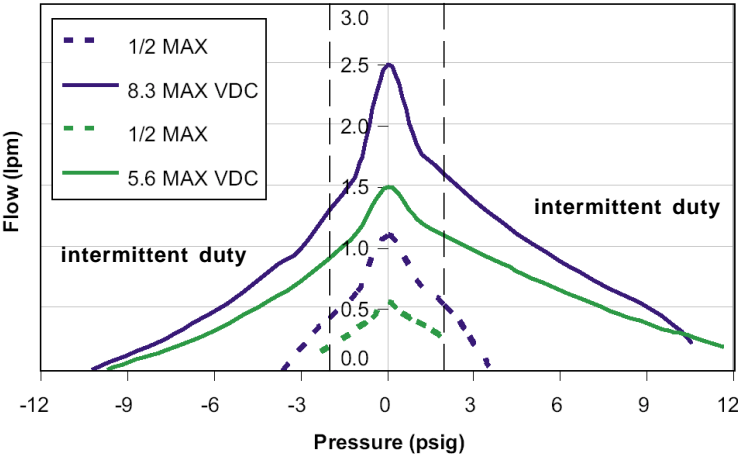

T3HP... (High Performance)

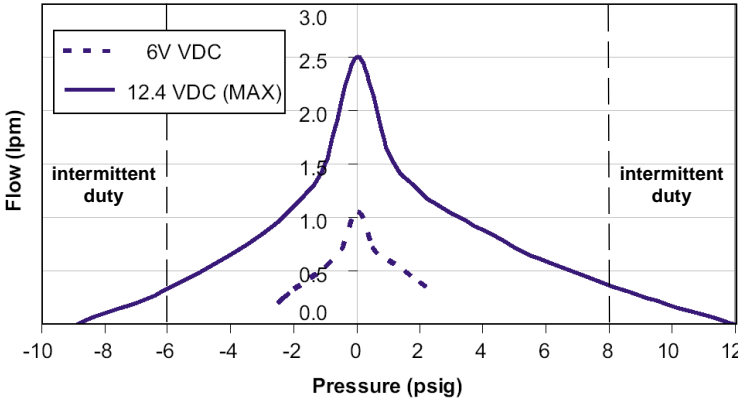

# T2-03

## Miniature diaphragm pumps

### OUTLINE DRAWING

#### T3CP... (COMPACT)

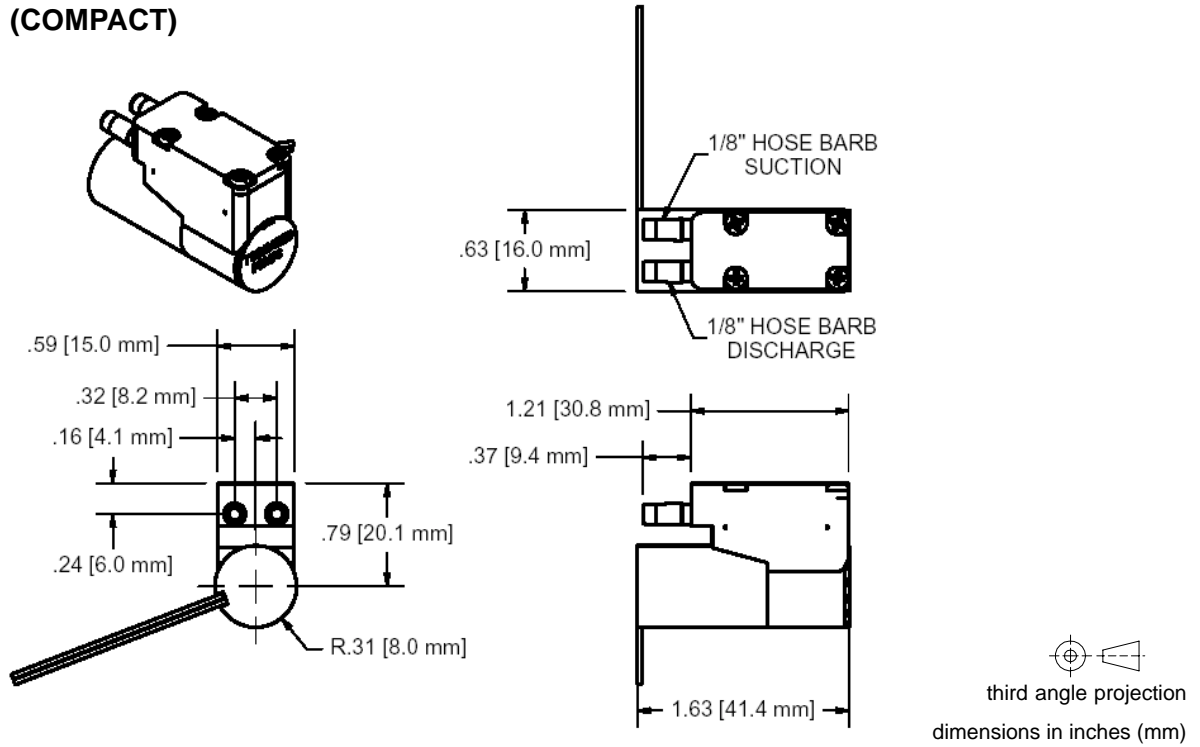

#### T3EP... (E-COMPACT)

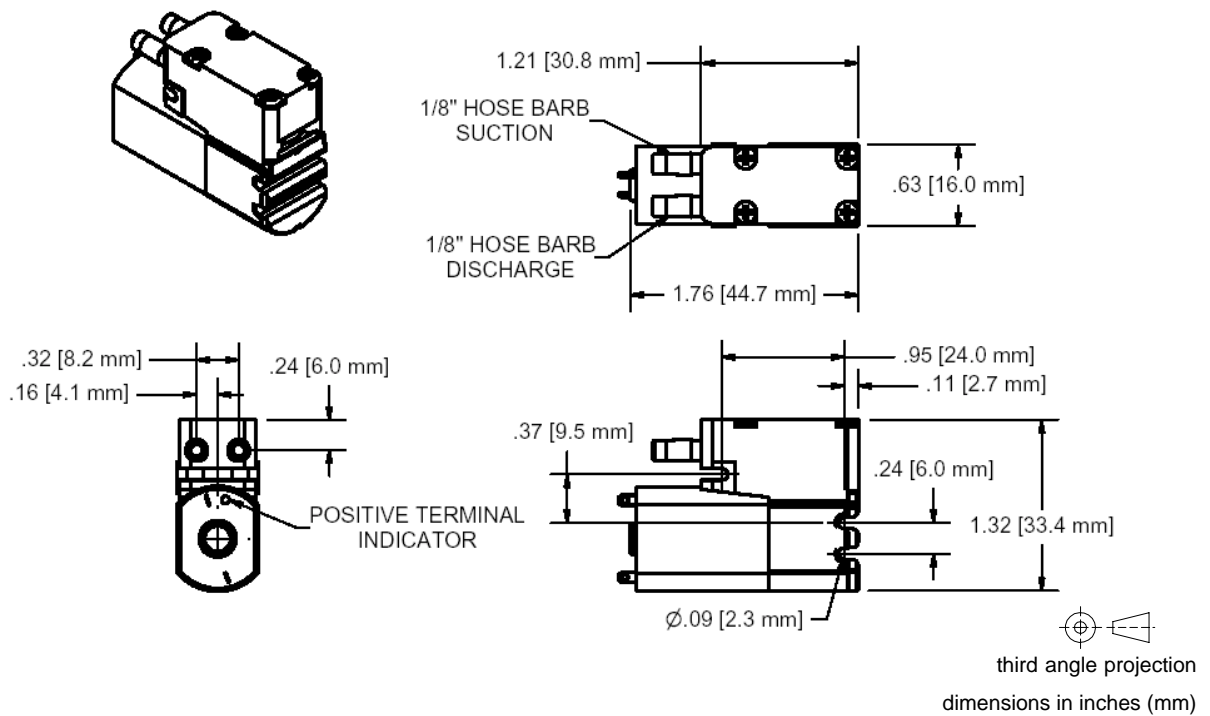

### OUTLINE DRAWING (cont.)

#### T3HP... (High Performance)

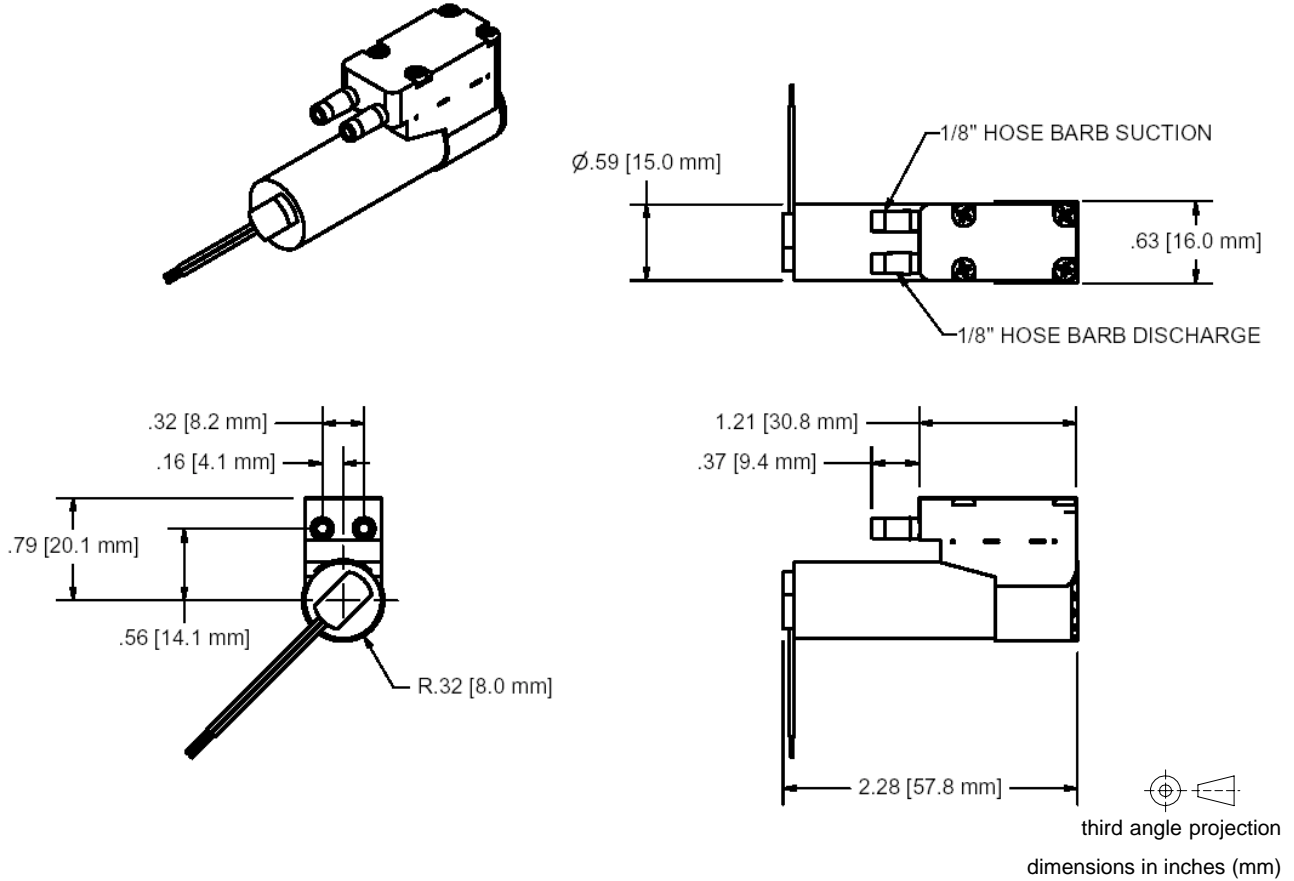

### ORDERING INFORMATION

Order no.	Model	Motor			Electrical termination	Max. flow	Valve	Diaphragm	Body/head
		Type	Nom. voltage	Max. power @ nom. voltage					
T3CP-1HE-06-1SNB	Compact	Ironless core	6 V <sub>DC</sub>	1.9 W	Wire leads	3.0 lpm	Silicone	Neoprene	ABS
T3CP-1HE-04-1SNB			4 V <sub>DC</sub>	1.2 W		2.5 lpm		EPDM	
T3CP-1HE-04-2SEB				0.4 W		1.1 lpm		Neoprene	
T3EP-1ST-08-1SNB	E-compact	Iron core	8.3 V <sub>DC</sub>	3.2 W	Solder tabs	2.5 lpm	FKM	FKM	PPS
T3EP-1ST-05-3FFP			5.6 V <sub>DC</sub>	2.3 W		1.5 lpm		Neoprene	
T3HP-1PD-12-1SNP	HP	Brush DC	12.4 V <sub>DC</sub>	1.2 W	Wire leads	2.5 lpm	Silicone	Neoprene	

**Note:** Custom specific modifications are widely available.  
Please contact your nearest Sensortech sales office for further information.

Sensortech reserves the right to make changes to any products herein. Sensortech does not assume any liability arising out of the application or use of any product or circuit described herein, neither does it convey any license under its patent rights nor the rights of others.