



The sensor series **SONOFLOW CO.55/xxxSD V2.0** with stainless steel housing and display – designed as clamp-on-sensors – detect the flow rate of liquids in plastic tubes of different diameters or materials within a few milliseconds.



For applications on tubes with higher outer diameters the sensors **SONOFLOW CO.55/xxxSDH V2.0** are equipped with a handle for an optimized handling for tube insertion.

The sensors have no contact to the medium or product. With stainless steel housing they are suitable for applications in fields with strict hygienic standards. Due to the current, frequency and switching outputs industrial dosing applications can be supported. The RS485 interface allows bus operation of up to 12 sensors in rough industrial environments.

The **SONOFLOW CO.55/xxxSD(H) V2.0** sensors with complete built-in electronics can be installed in machines or apparatuses. The display shows the current flow rate and the measuring state.

In addition to our standard sensors, we also manufacture customer-specific solutions regarding housing materials, colors, mechanical dimensions, customized output specifications and parameter settings.

Overview sensors

Specification SONOFLOW	Order-No.	Measuring channel (CH = CW)	Dimensions (L x W x H)	Weight
CO.55/035SD V2.0	200 08 0036	□ 3.5 mm	44 x 64 x 31 mm	380 g
CO.55/060SD V2.0	200 08 0032	□ 6.0 mm	44 x 64 x 33 mm	420 g
CO.55/080SD V2.0	200 08 0057	□ 8.0 mm	44 x 64 x 35 mm	430 g
CO.55/100SD V2.0	200 08 0030	□ 10.0 mm	44 x 64 x 38 mm	480 g
CO.55/140SD V2.0	200 08 0058	□ 14.0 mm	44 x 64 x 42 mm	520 g
CO.55/160SD V2.0	200 08 0031	□ 16.0 mm	44 x 64 x 45 mm	540 g

Specification SONOFLOW (with Handle)	Order-No.	Measuring channel (CH x CW)	Dimensions: L x W x H [Height without handle]	Weight
CO.55/190SDH V2.0	200 08 0070	□ 19.0 mm	50 x 88 x 64 [43] mm	800 g
CO.55/230SDH V2.0	200 08 0048	□ 23.0 mm	50 x 88 x 66 [45] mm	800 g
CO.55/260SDH V2.0	200 08 0042	□ 26.0 mm	50 x 88 x 68 [47] mm	800 g
CO.55/340SDH V2.0	200 08 0051	30 x 34.0 mm	50 x 88 x 74 [53] mm	800 g

Tubing properties

Material: PVC, Silicone, PTFE, PFA, FEP, TPE, Tygon, PE, etc.
Outer diameter: ≈ 4 mm ... 35 mm

	<p>Note</p> <p>The listed tubes are examples for frequently used tubes and the given OD and ID are guiding values. The sensors are also applicable for further tubing diameters, up to 2". The selection of the right sensor depends on tubing dimensions as well as on tubing properties. If possible, provide us with a tubing sample.</p>
---	---

Sensors are factory calibrated with the highlighted tubing in the following list.
Calibration to customer specific tubing upon request, please contact our sales team.

Specification SONOFLOW	Tubing OD		Tubing ID		Wall thickness		Tubing
	[mm]	[inch]	[mm]	[inch]	[mm]	[inch]	
CO.55/035SD V2.0	4.0 mm		3.0 mm		0.5 mm		PVC, Deutsch & Neumann™ 3500304
	3.96 mm	5/32" 0.1563"	0.79 mm	1/32" 0.031"	1.6 mm	1/16" 0.0625"	Platinum-Cured Silicone, Cole-Parmer® L/S 13, Masterflex®
CO.55/060SD V2.0	7.0 mm		5.0 mm		1.0 mm		PVC, ESSKA, 702101051099
	6.35 mm	1/4" 0.25"	3.18 mm	1/8" 0.125"	1.6 mm	1/16" 0.0625"	Platinum-Cured Silicone, Cole-Parmer® L/S 16, Masterflex®
CO.55/080SD V2.0	9.0 mm		6.0 mm		1.5 mm		PVC, ESSKA, 702101061599
	9.53 mm	3/8" 0.375"	6.35 mm	1/4" 0.25"	1.6 mm	1/16" 0.0625"	Platinum-Cured Silicone, Cole-Parmer® L/S 17, Masterflex®
CO.55/100SD V2.0	12.0 mm		9.0 mm		1.5 mm		PVC, ESSKA, 702101091550
	11.13 mm	7/16" 0.438"	6.35 mm	1/4" 0.25"	2.39 mm	3/32" 0.0938"	Platinum-Cured Silicone, Cole-Parmer® L/S 24, Masterflex®
CO.55/140SD V2.0	16.0 mm		10.0 mm		3 mm		PVC, ESSKA, 702101103050
	15.88 mm	5/8" 0.625"	9.53 mm	3/8" 0.375"	3.18 mm	1/8" 0.125"	Platinum-Cured Silicone, Cole-Parmer® I/P 73, Masterflex®
CO.55/160SD V2.0	19.0 mm		14.0 mm		2.5 mm		PVC, ESSKA, 702101142550
	19.05 mm	3/4" 0.75"	12.7 mm	1/2" 0.5"	3.18 mm	1/8" 0.125"	Platinum-Cured Silicone, Cole-Parmer® I/P 82, Masterflex®
CO.55/190SDH V2.0	22.0 mm		16.0 mm		3 mm		PVC, ESSKA, 702101163050
	22.23 mm	7/8" 0.875"	15.88 mm	5/8" 0.625"	3.18 mm	1/8" 0.125"	Platinum-Cured Silicone, Saint Gobain, Sani-Tech® STHT®-C-625-4
CO.55/230SDH V2.0	25.4 mm	1"	15.88 mm	5/8" 0.625"	4.76 mm	3/16" 0.1875"	Platinum-Cured Silicone, Saint Gobain, Sani-Tech® STHT®-C-625-5
CO.55/260SDH V2.0	28.56 mm	1 1/8" 1.125"	19.05 mm	3/4" 0.75"	4.76 mm	3/16" 0.1875"	Platinum-Cured Silicone, Saint Gobain, Sani-Tech® STHT®-C-750-5
CO.55/340SDH V2.0	34.93 mm	1 3/8" 1.375"	25.4 mm	1"	4.76 mm	3/16" 0.1875"	Platinum-Cured Silicone, Saint Gobain, Sani-Tech® STHT®-C-1000-5

Manufacturers:

PVC Tubing: Deutsch & Neumann GmbH, 10585 Berlin (Germany);
ESSKA.de GmbH, 20537 Hamburg (Germany)

Silicone Tubing: Cole-Parmer®, Vernon Hills, IL 60061 United States;
Saint Gobain Performance Plastics, Solon, OH 44139

Accuracy

Specification SONOFLOW	Upper range value	Accuracy for water: adjusted at 23 °C ± 2 K and 1 bar on specified tube (listed)	
CO.55/035SD V2.0	3 000 ml/min	0 ... 300 ml/min: ± 6 ml/min	300 ... 3 000 ml/min: ± 2 %
CO.55/060SD V2.0	6 000 ml/min	0 ... 600 ml/min: ± 12 ml/min	600 ... 6 000 ml/min: ± 2 %
CO.55/080SD V2.0	8 000 ml/min	0 ... 800 ml/min: ± 16 ml/min	800 ... 8 000 ml/min: ± 2 %
CO.55/100SD V2.0	10 000 ml/min	0 ... 1 000 ml/min: ± 20 ml/min	1 000 ... 10 000 ml/min: ± 2 %
CO.55/140SD V2.0	14 000 ml/min	0 ... 1 400 ml/min: ± 28 ml/min	1 400 ... 14 000 ml/min: ± 2 %
CO.55/160SD V2.0	18 000 ml/min	0 ... 1 800 ml/min: ± 36 ml/min	1 800 ... 18 000 ml/min: ± 2 %
CO.55/190SDH V2.0	40 000 ml/min	0 ... 4 000 ml/min: ± 80 ml/min	4 000 ... 40 000 ml/min: ± 2 %
CO.55/230SDH V2.0	50 000 ml/min	0 ... 5 000 ml/min: ± 100 ml/min	5 000 ... 50 000 ml/min: ± 2 %
CO.55/260SDH V2.0	70 000 ml/min	0 ... 7 000 ml/min: ± 140 ml/min	7 000 ... 70 000 ml/min: ± 2 %
CO.55/340SDH V2.0	140 000 ml/min	0 ... 14 000 ml/min: ± 280 ml/min	14 000 ... 140 000 ml/min: ± 2 %

Accuracy and calibration

Example for accuracy of **SONOFLOW CO.55/035SD** in the lower flow range, achieved by calibration to customer specific conditions:

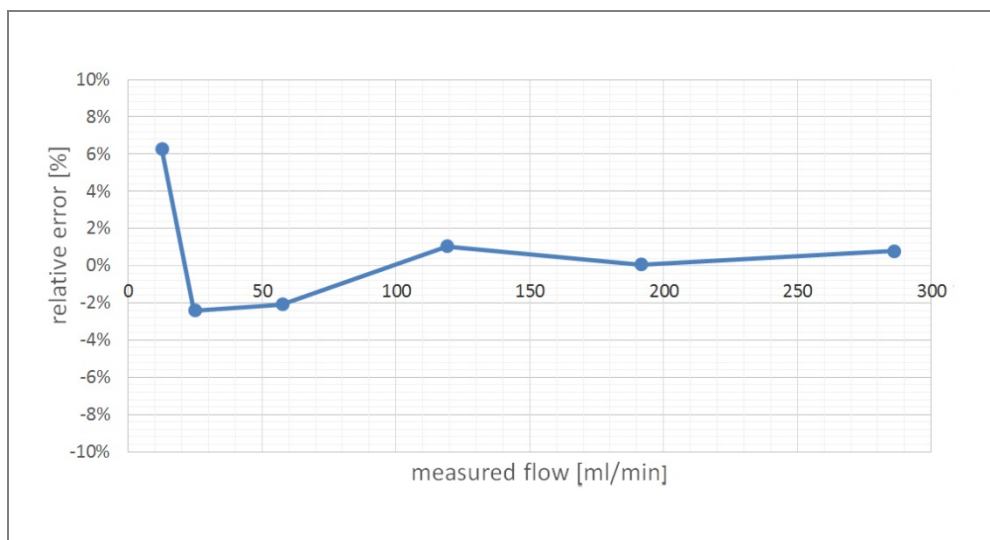

Accuracy depends on tubing, temperature, fluid properties and other conditions. Calibration to customer tubing, fluid, flow range, temperature, etc. on request.

Technical data

SONOFLOW CO.55/xxxSD(H) V2.0 Flow Sensor for liquids	
Measuring method	Ultrasound, two sections of measurements, dry coupling, no couplant required
Calibration	Sensors are factory calibrated for water at 23 °C ± 2 K, tube end depressurized (0 bar); other calibration on request
Mounting	Fixed installation: CO.55/xxxSD V2.0 M4, 8 mm deep 4 fixing holes CO.55/xxxSDH V2.0 M5, 8 mm deep
Media	Water, human blood or other acoustically transparent liquids
Sensor materials	Measuring channel: PMMA black, Display protection: PMMA transparent, Housing: stainless steel 1.4305
Operating voltage	12 ... 30 VDC, maximum ripple 10 %, protection against reverse-polarity
Current consumption	Maximum 30 mA (with open current, frequency and switching output)
Electrical connection	8-pin M12 Connector, DIN EN 61076-2-101:2012
Shielding	Required: via cable / housing (mounting screws)
Interfaces	<ul style="list-style-type: none"> • Current output for flow rate: 0/4 ... 20 mA • Frequency output for flow rate: 0 ... 20 kHz, 5 V digital • RS485 interface: bus-capable • Switching output: configurable as PNP / NPN / Push-Pull, 0 ... 30 V • Digital input
Current output for flow rate	<p>⚠ NOTE: Load to GND. The max. load depends on the operating voltage: 12 V → 250 Ω, 15 V → 500 Ω, 24 V → 1 kΩ, 30 V → 1.2 kΩ</p>

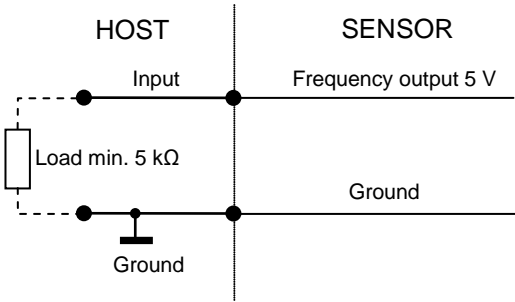
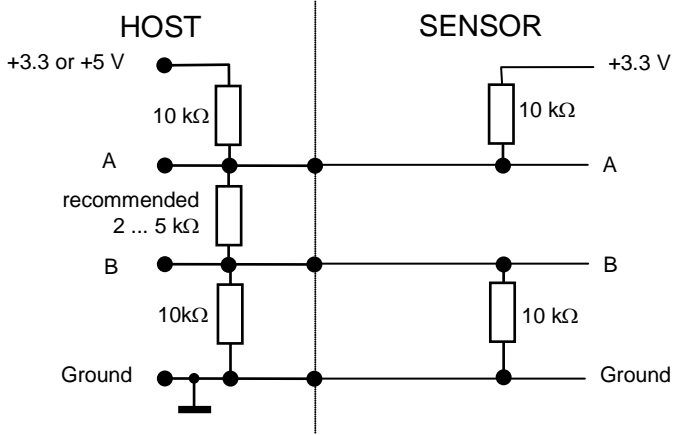
Frequency output for flow rate	
RS485 interface	<p>Half-duplex operation / 115.200 baud / no parity / 1 stop bit / no handshaking</p> <p>⚠ NOTE: Please find the description of the serial protocol for details (upon request).</p>  <p>Recommended electrical connection of the RS 485 interface</p> <p>⚠ CAUTION! If the interface is not used, it does not necessarily has to be connected; the two pins A and B can remain open.</p>
RS485 Bus operation	<p>The sensor supports bus operation with max. 12 subscribers. The default address is #1.</p> <p>⚠ NOTE: The address can be changed with the help of the SONOFLOW Monitor. Permitted are addresses from #1 ... #12. → Menu: Identification RS485 address</p>
Switching output	<p>Freely configurable: e.g. adapting batch process or threshold switch of flow, Maximum 100 mA</p>

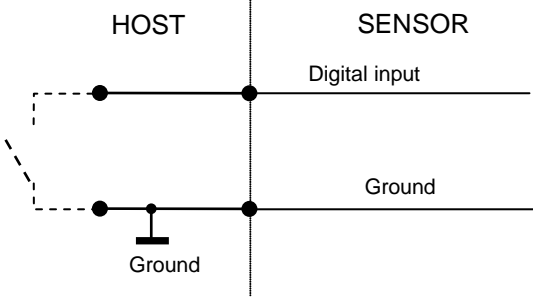
<p>Digital input</p>	<p>Freely configurable: for example for zero point calibration of flow or start dosing processes</p> <p>Voltage resistant up to 30 V</p>
	
<p>Ambient- / Media temperature</p>	<p>0 ... 60 °C, other temperatures available on request</p>
<p>Storage temperature</p>	<p>-20 ... +70 °C</p>
<p>Protection class</p>	<p>IP65</p>
<p>Directives and standards</p>	<ul style="list-style-type: none"> • EMC directive 2004/108/EG • RoHS: 011/65/EU, exception: III 7cI/ IV 15 • Acoustic emission: IEC 61157
<p>Maintenance</p>	<p>Maintenance-free</p>
<p>Scope of delivery</p>	<ul style="list-style-type: none"> • SONOFLOW CO.55/xxxSD(H) V2.0 according to specification • User documentation
<p>Optional accessories</p>	<ul style="list-style-type: none"> • 8-pin M12 sensor cable, length 2 m / 5 m • Calibration protocol <p>SONOFLOW Monitor for setting parameters and recording measurements consisting of</p> <ul style="list-style-type: none"> • USB Data Converter, type 013 for the connection to a computer • Power supply unit (24 VDC) • 8-pin M12 connecting cable, length 2 m • USB cable, type A-B, length 2 m • CD with Software SONOFLOW Monitor and driver for Windows

Display



Start screen:

- displayed for 5 seconds
- shows all information about the identity of sensor



Measuring screen:

(Indication of units adaptable with SONOFLOW Monitor)

- shows the current flow rate and the measuring state
- in intervals of 30 seconds the internal temperature of sensor is displayed



Note: The internal temperature differs from the medium temperature

The displayed information can be customized via software settings. Possible: various units, volume or running time



Error screen:

- shows error codes (see next page)

In case of displayed error codes contact the manufacturer.

Technical data display

Format	128 x 64 Dots
Color	White
Viewing area (W x H)	23.7 x 12.8 mm

Error code	Error	Possible causes and recommended measures
F 0x00	No Measuring error	
F 0x01	Signal value not plausible	Check if:
F 0x10	Signal value not plausible	<ul style="list-style-type: none"> the tubing is firmly secured in the sensor and cannot move?
F 0x81 or higher	Signal value not plausible, no measurement possible	<ul style="list-style-type: none"> the tubing is filled with a liquid, without large gas bubbles? the lid of the sensor is closed?
G 0x00	No device error	
G 0x01	Checksum error in parameters	Recheck parameters. (SONOTEC monitor software can be used).
G 0x02	At least one invalid parameter	
G 0x04	Temperature sensor failed	Power OFF/ power ON the sensor.
G 0x08	DAC failed	If the error persists, return the sensor for repair.
G 0x10	Display failed	

Electrical connection

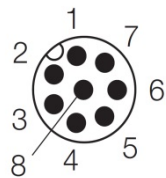

Male connector
(at the sensor)

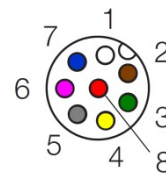

Female connector
(at the cable)

M12 connecting cable	Pin	Color	Connection
Assignment	1	White	Ground
	2	Brown	Operating voltage +12 ... 30 VDC
	3	Green	Current output (0/4 ... 20 mA)
	4	Yellow	RS485 B
	5	Grey	RS485 A
	6	Pink	Frequency output 0 ... 20 kHz
	7	Blue	Switching output: PNP / NPN / Push-Pull
	8	Red	Digital input

Technical drawings

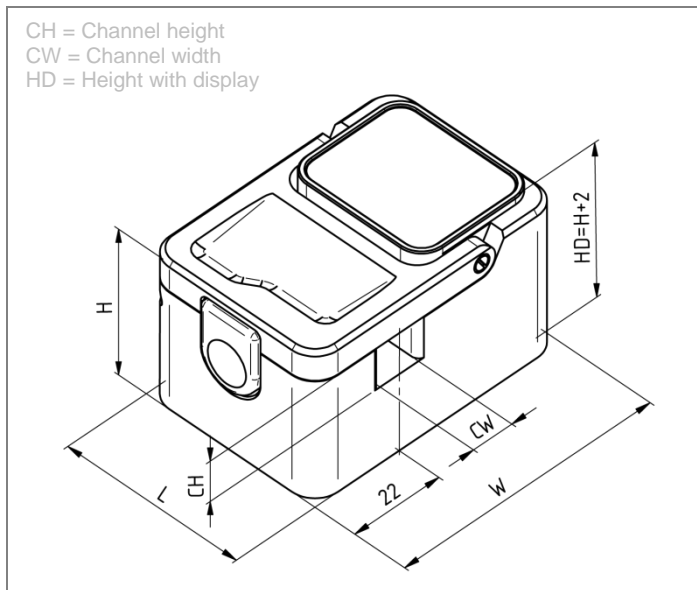

Figure 1: Dimensions SONOFLOW CO.55/xxxSD V2.0 (The drawings are not to scale)

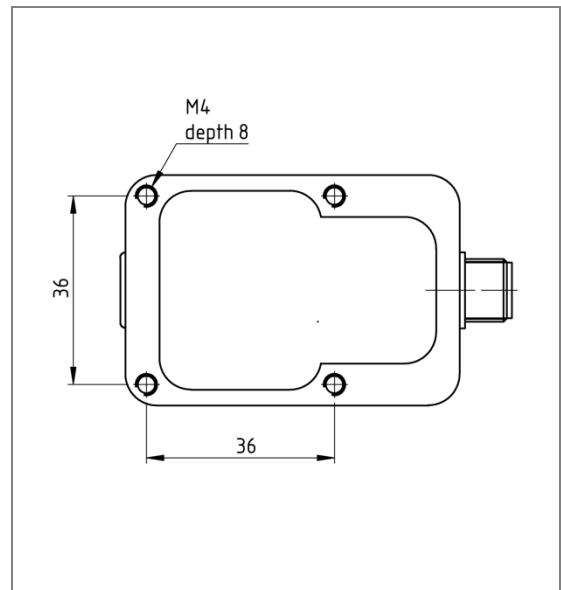

Figure 2: Rear side with drill holes for mounting SONOFLOW CO.55/xxxSD V2.0

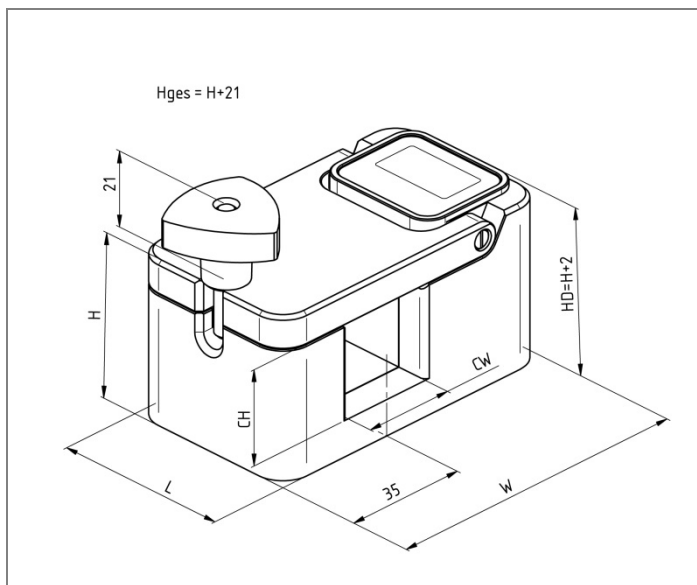

Figure 3: Dimensions SONOFLOW CO.55/xxxSDH V2.0 (The drawings are not to scale)

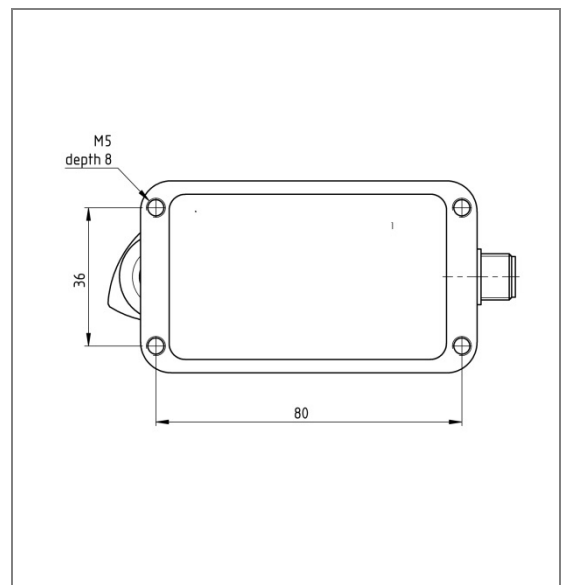

Figure 4: Rear side with drill holes for mounting SONOFLOW CO.55/xxxSDH V2.0

Information is subject to change without notice!

HEADQUARTERS GERMANY

SONOTEC
 Ultraschallsensorik Halle GmbH
 Nauendorfer Str. 2
 06112 Halle (Saale), Germany

Tel.: +49 (0)345 / 133 17- 0
 sales_eu@sonotec.de
 www.sonotec.eu

AMERICAS

SONOTEC US Inc.
 190 Blydenburgh rd
 Suite 8 2nd floor
 Islandia, New York 11749, USA

Phone: +1 631 / 415 4758
 sales@sonotecusa.com
 www.sonotecusa.com