

T2-03

Micro Diaphragm Pumps (air/gas)

Up to 2.5 LPM Free Flow

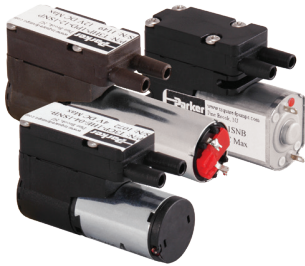

Applications

- Gas Sampling
- Fixed Gas Detectors
- Medical Instruments
- Aerosols and Particle Analysis
- Combustion Analyzers

T2-03 micro diaphragm pump series is ideal for higher performance, fixed and portable air and gas detection, and medical applications requiring flow up to 2.5 lpm. T2-03 pumps are proven in fixed and portable applications for sampling of hazardous gases and vapors typical of industrial and mining operations.

Features

- The valve design has been optimized to provide the highest flow rates available with the lowest power draw in this package size. Lower power results in longer battery life and smaller instrument size.
- The wear components of these pumps have been designed to provide maximum life. Many applications for these pumps require 10,000+ hours of operation.
- The pumps fit into the extremely tight spaces demanded of today's handheld instruments, such as portable gas detectors and portable instruments such as handheld gas detectors and medical devices. The lightweight design minimizes instrument weight.
- RoHS compliant. 

Product Specifications*

Physical Properties

Operating Environment¹:
32 to 122°F (0 to 50°C)
Storage Environment:
14 to 122°F (-10 to 50°C)
Humidity:
5-95% Relative Humidity
Noise Level²:
As low as 45dB
Pump Assembly Rated Life³:
eCompact - 5,000 hrs
Compact - 10,000 hrs
HP - 10,000 hrs
<i>Pressure and speed dependent.</i>
Weight:
1.2 oz. (33 g) eCompact
1.2 oz. (33 g) Compact
1.5 oz. (42 g) HP

Wetted Materials

Diaphragm:
Neoprene, EPDM, FKM
Valves:
Silicone, FKM
Pump Head:
ABS, PPS

Electrical

Motor Type:
PMDC Iron Core Brush, Coreless Brush
Nominal Motor Voltages⁴:
4, 5.6, 8.3, 12.4 VDC
Max Power at Nominal Voltage:
eCompact - PMDC Iron Core Brush 2.4 Watts (298 mA @ 8VDC)
Compact - Coreless Brush Motor 2.3 Watts (386 mA @ 6 VDC)
HP - Coreless Brush Motor 0.7 Watts (88 mA @ 8 VDC)
Electrical Termination:
PMDC Iron Core Brush - Solder Tabs Coreless Brush - 5.7 in (145 mm) Wire Leads
Current Range⁵:
18 - 411 mA
Inductance⁶:
eCompact: 18.64 mH max@1kHz/50mV
Compact: 0.47 mH max@1kHz/50mV
HP: 3.4 mH max@1kHz/50mV

Pneumatic

Head Configuration:
Single
Maximum Flow:
2.5 LPM
Maximum Intermittent Pressure⁷:
12 psi (832 mbar)
Maximum Continuous Pressure:
2 psi (138 bar) - eCompact PMDC Iron Core Brush, Compact Coreless Brush Motor 8 psi (555 mbar) - HP Coreless Brush Motor
Maximum Intermittent Vacuum⁷:
20.8 in Hg (527 mm Hg)
Maximum Continuous Vacuum:
eCompact PMDC Iron Core Brush 4 psi (102 mbar) Compact Coreless Brush Motor 4 psi (102 mbar) HP Coreless Brush Motor 12 psi (305 mbar)
Filtration:
40 micron recommended
Efficiency at Free Flow⁸:
eCompact PMDC Iron Core Brush Motor: 3.56 LPM/Watt (P/N: T3EP-1ST-05-3FFP)
Compact Coreless Brush Motor: 11.92 LPM/Watt (P/N: T3CP-1HE-04-2SEB)
HP Coreless Brush Motor: 15.28 LPM/Watt (P/N: T3HP-1PD-12-1SNP)

* See Appendix A for details.



Performance Specifications

T2-03 e-Compact - PMDC Iron Core Motor

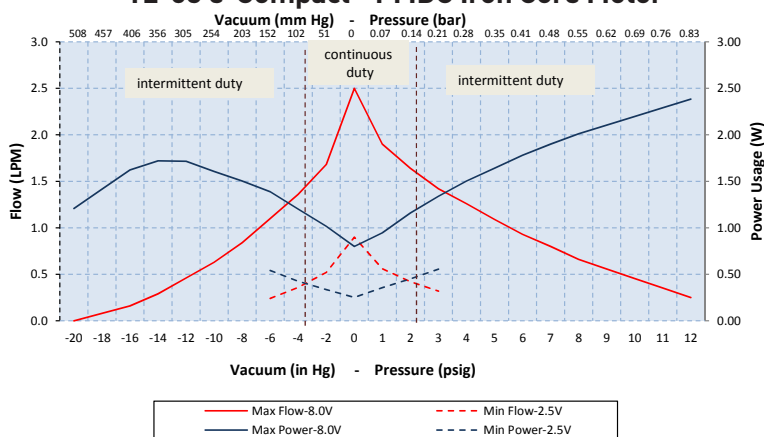

T2-03 Compact Pump - Coreless Brush Motor

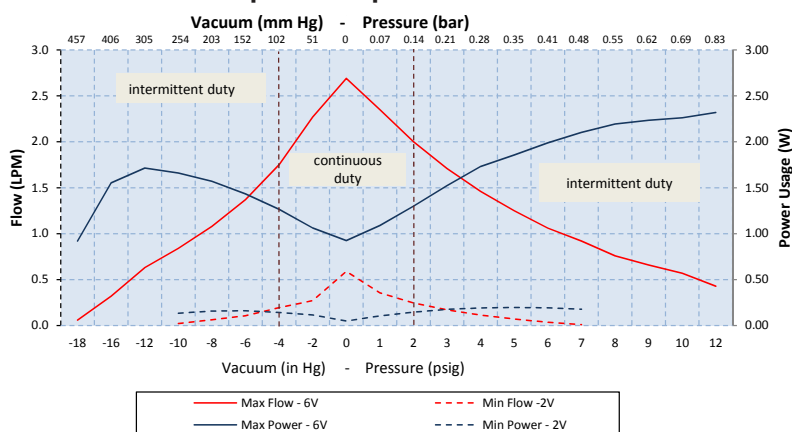

T2-03 HP - Coreless Brush Motor

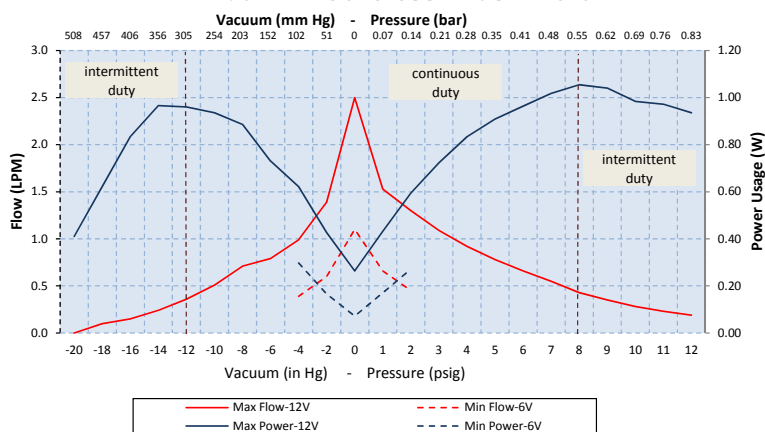

The above graphs represent examples of performance for the pumps series handling air at 800 feet [244M] above sea level at 75° F [24° C]. Performance will vary depending on barometric pressure and media temperature. Curves are representative of standard pump configurations. Pump configurations could be customized for higher or lower flows, depending on specific customer requirements.

Please contact Parker Precision Fluidics Applications Engineering for other considerations.



T2-03

Micro Diaphragm Pumps (air/gas)

Sizing and Selection

T2-03 Series

PMDC Iron Core Brush Motor (eCompact)

Coreless Brush Motor (Compact)

Coreless Brush Motor (HP)

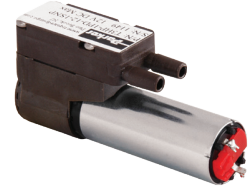
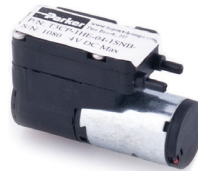

	eCompact	Compact	HP
Inductance ⁶	Good	Best	Better
Efficiency at Free Flow ⁸	Good	Better	Best
Life ³	Good - 5,000 hours	Best - 10,000 hours	Best - 10,000 hours
Size/Weight	Better	Best	Good
Cost	Best	Better	Good

Mounting Guidelines:

- For eCompact, Parker recommends mounting with (2) #1 screw or using a nylon cable tie with a length of at least 4" (100 mm)
- For Compact & HP, Parker recommends using a nylon cable tie with a length of at least 4" (100 mm)

Port Connections:

- Barbs are sized for 1/8" ID tubing, 70-80 durometer recommended.
- Flow direction is marked on the pump head with arrows.

Mechanical Integration

Dimensions

PMDC Iron Core Brush Motor (eCompact)

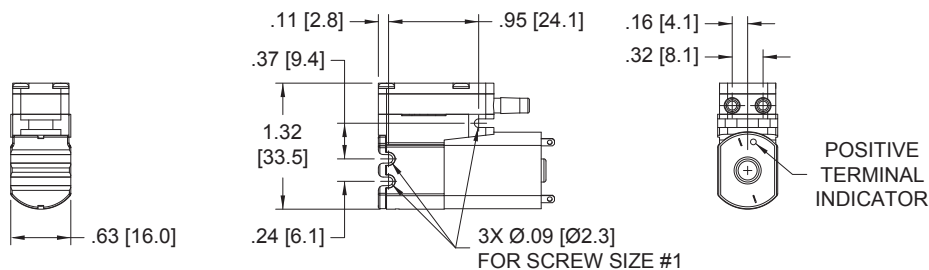
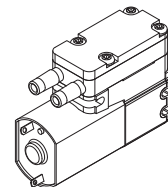
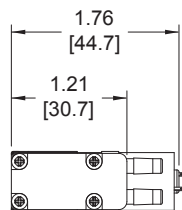

UNITS
IN. [mm.]



Dimensions

Coreless Brush Motor (Compact)

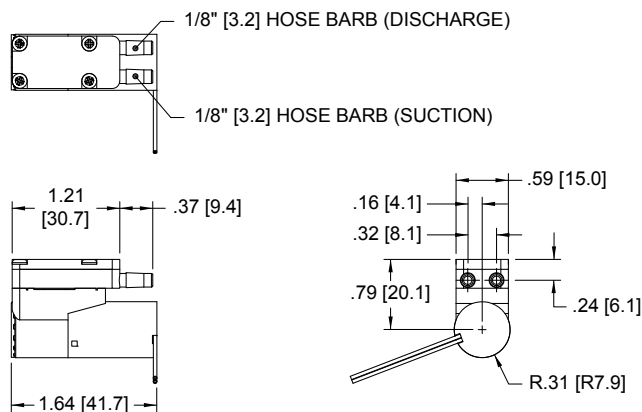

UNITS
IN. [mm.]

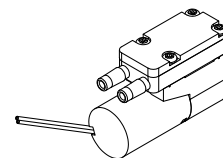

Coreless Brush Motor (HP)

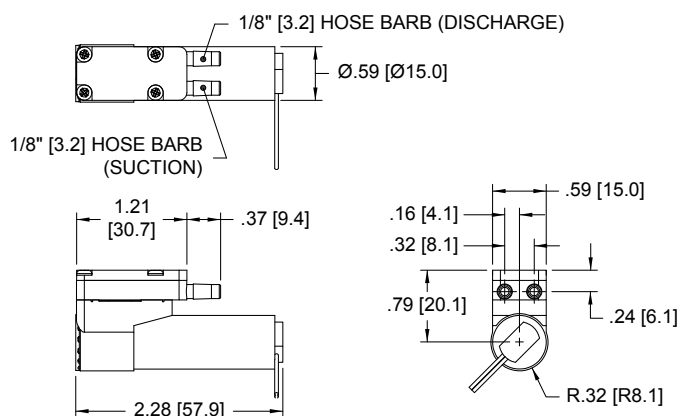

UNITS
IN. [mm.]

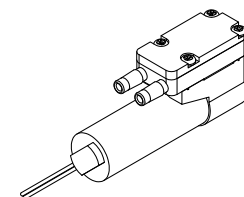

Electrical Integration and Motor Control

If application requires variable flow, motor control options are available, as follows:

PMDC Iron Core Brush Motor (eCompact)

2 Solder Tabs	Positive terminal marked on pump motor
---------------	--

Coreless Brush Motor (Compact & HP)

2 Wire	Red (+), Black (-)
Wire specification	28 AWG Wire lead length 5.7" (145 mm)



T2-03

Micro Diaphragm Pumps (air/gas)

Electrical Integration and Motor Control cont'd

Key Things to Remember

5" (127 mm) flying Leads are the standard electrical connection method to the pump (eCompact standard connection is tabs). Contact Applications for other connection requirements.

The pump lead wires are non-polarized.

The pump can be controlled by DC voltage or PWM. The minimum recommended PWM frequency is 20kHz.

The pump flow and pressure can be controlled by adjusting the input voltage from zero to maximum rated voltage.

The pump is not a pressure holding device. An external check valve is recommended, if there is a pressure holding requirement.

Pump orientation does not affect performance or life.

Typical Flow Diagram

Hand Held Gas Detection

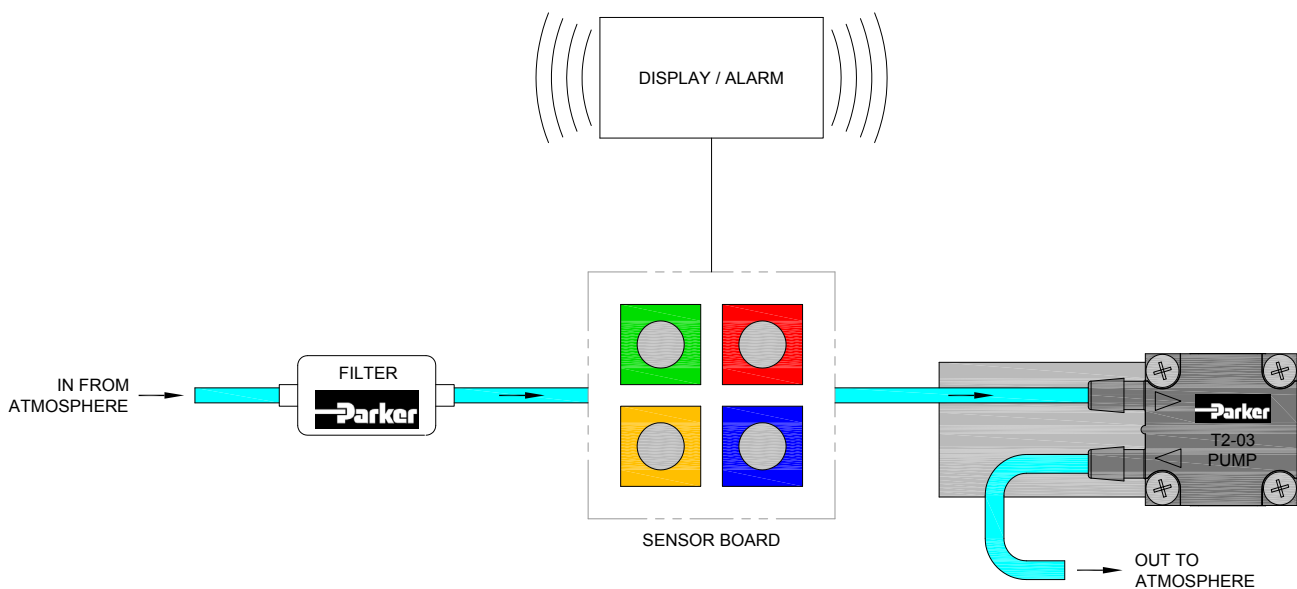

Chemical Compatibility Chart*

Chemical	Chemical Compatibility of Wetted Path Materials					
	FKM	EPDM	ABS	Neoprene Rubber(CR)	PPS	Silicone
Air	1	1	1	1	1	1
Ozone (1000 ppm)	4	4	2	3	1	1
Oxygen	1	1	1	1	1	2
Ethylene (Ethene)	1	4	-	1	1	4
Acetylene	1	1	2	2	1	3
Propane	1	4	2	1	1	4
Methane	1	4	4	2	1	4
Nitrogen	1	1	1	1	1	1
Carbon Dioxide	1	2	2	1	1	2
Halothane (Up to 5%)	1	4	1	4	1	4

Compatibility Legend

- EXCELLENT**
Minimal or no effect
- GOOD**
Possible swelling and/or loss of physical properties
- DOUBTFUL**
Moderate or severe swelling and loss of physical properties
- NOT RECOMMENDED**
Severe effect and should not be considered

Note: Consult factory for other gases.

*The above is an Abbreviated Chemical Compatibility Chart. Please consult factory for details.

Ordering Information

T2-03 Micro Pumps

Configuration	Vacuum: LPM @ Load					Free Flow	Pressure: LPM @ Load					Max		Motor Type	VDC	mA	Wetted Materials ²
	18 in Hg	16 in Hg	12 in Hg	8 in Hg	4 in Hg		0	2 psig	4 psig	6 psig	8 psig	10 psig	Vac in Hg				
T3CP-1HE-04-1SNB	457 mm Hg	406 mm Hg	305 mm Hg	0.3	0.9	2.5	1.1	0.5				8.6	4.5	Coreless Brush	4	313	CR, VMQ, CR
T3CP-1HE-04-2SEB				0.1	0.3	1.1	0.5	0.2				10.4	5.5	Coreless Brush	4	103	EPDM, VMQ, CR
T3CP-1HE-06-1SNB				0.6	1.2	2.8	1.5	0.8	0.5			12.2	6.5	Coreless Brush	6	317	CR, VMQ, CR
T3EP-1ST-05-3FFP			0.3	0.6	0.8	1.5	1.2	0.7	0.6	0.4		16.7	11.7	PMDC Brush	5.6	411	FKM
T3EP-1ST-08-1SNB		0.2	0.6	0.7	1.3	2.5	1.6	1.2	0.7	0.6		20.8	10.5	PMDC Brush	8.3	385	CR, VMQ, CR
T3HP-1PD-12-1SNP		0.2	0.4	0.7	1.0	2.5	1.3	0.9	0.7	0.4	0.3	18.0	12	Coreless Brush	12.4	97	CR, VMQ, CR

1. PCD: Peak Current Draw 2. CR: Neoprene, VMQ: Silicone, FKM: Fluorocarbon, EPDM: Ethylene Propylene Diene Monomer

Please click on the Order On-line button below (or go to www.parker.com/precisionfluidics/t3) to configure your T2-03 Micro Diaphragm Pump.

Serviceable – PPF products are designed for use through the rated life and Parker does not sell replacement parts, nor is it recommended to service these in the field

Note: In addition to Parker’s innovative and flexible pump designs, we offer applications engineering expertise to our customers in order to configure and recommend the optimal pump for the application. Contact Parker Applications Engineering to discuss and configure alternate pump configurations to meet your specific application requirements. Providing information on the following requirements will assist us in developing an optimal solution for your application:

- Noise
- Operating Pressure / Vacuum
- Power Consumption
- Life Requirement
- Size
- Motor Control
- Media
- Voltage



Parker Hannifin Precision Fluidics Division reserves the right to make changes. Drawings are for reference only.



Appendix A

All performance data is typical based on standard conditions: 70°F and 14.7 psia (21°C and 1 bar).

1. Duty Dependent. For operation above 122°F (50°C) consult factory
2. Noise is dependent on the configuration and operation of the pump in the application. Parker has the ability to tailor the pump configuration when noise is a critical criterion in the effort to meet the performance requirements of the application. Noise level is tested to Parker protocol P-105.
3. Life rating can vary depending on application and operating conditions.
4. Custom motor options available. Custom motors may require a significant application potential. The standard motors can be configured with a special winding to meet a particular operation point at a specified voltage
5. Current range is dependent on motor type, voltage, pressure/vacuum and flow requirement. Lower levels possible depending on application.
6. Inductance can be used to measure the viability of a component in a device requiring intrinsic safety.
7. Maximum intermittent pressure/vacuum data is a pump capability guideline for applications that go beyond the maximum continuous levels for short periods of time. Please consult customer specific requirements with the factory or Applications Engineering.
8. Pump efficiency is a measure of the flow rate generated per unit of power consumed. Efficiency may change dependent on application and operating condition at free flow.

