

# T2-04

Up to 6.7 LPM Free Flow



## Micro Diaphragm Pumps (air/gas)

The T2-04 is a high flow and ultra compact pump that is ideal for portable air and gas detection applications. Delivering flow up to 6.7 lpm, the pump works well in environments where high efficiency for extended battery life, high performance, low cost, minimal weight, and compact size are critical.

### Features

- The pump with patented valve design is optimized to provide best-in-class efficiency/size ratio especially for low vacuum applications. Low power consumption enables longer battery life for small instruments.
- The pump fits into the tight spaces demanded of today's battery-powered instruments. The lightweight design keeps the instrument weight minimized.
- The high efficiency coreless brush motor can satisfy intrinsic safety requirements. It has been proven in applications for sampling of medical gases, hazardous gases, particles, and aerosols in a range of fixed and portable instruments.
- Compact dual head design with internal flow paths that require only one set of barbs for intake and discharge simplifies plumbing requirements
- RoHS Compliant 

### Typical Applications

- Particle Detection
- Pathogen Detection
- Compression Therapy
- Wound Therapy
- Fuel Cell

## Product Specifications\*

### Physical Properties

<b>Operating Environment<sup>1</sup>:</b>
32 to 122°F (0 to 50°C)
<b>Storage Temperature:</b>
14 to 122°F (-10 to 50°C)
<b>Media:</b>
Air, Argon, Helium, Nitrogen, Oxygen, and other non-reacting gases
<b>Humidity:</b>
5-95% Relative Humidity
<b>Noise Level<sup>2</sup>:</b>
As low as 45dB
<b>Pump Assembly Rated Life<sup>3</sup>:</b>
Up to 5,000 hrs
<b>Weight:</b>
3.3 oz (94 g)

### Electrical

<b>Motor Type:</b>
High Efficiency Coreless Brush
<b>Nominal Motor Voltages<sup>4</sup>:</b>
6 VDC
<b>Max Power in Continuous Range:</b>
2.6 Watts
<b>Electrical Termination:</b>
28 AWG Wire Leads lead length 5" (127 mm)
<b>Current Range<sup>5</sup>:</b>
50 - 425 mA
<b>Inductance<sup>6</sup>:</b>
Coreless Brush: 0.266 mH max @ 1kHz/50mV

### Pneumatic

<b>Head Configuration:</b>
Dual (Single Ported)
<b>Maximum Flow:</b>
6.7 lpm
<b>Maximum Intermittent Pressure<sup>7</sup>:</b>
16 psi (1103 mbar)
<b>Maximum Continuous Pressure:</b>
2 psi (138 mbar)
<b>Maximum Intermittent Vacuum<sup>7</sup>:</b>
-18.7 in Hg (-475 mm Hg)
<b>Maximum Continuous Vacuum:</b>
-4 in Hg (-101 mm Hg)
<b>Filtration:</b>
40 micron recommended
<b>Efficiency at Free Flow<sup>8</sup>:</b>
Coreless Brush Motor: 10 LPM/Watt @ 3 VDC (P/N: T4-2HE-06-1SCA)

### Wetted Materials

<b>Diaphragm:</b>	<b>Pump Head:</b>
Neoprene Rubber	Polyphthalamide (PPA)
<b>Valves:</b>	
Silicone	

\* See Appendix A for details.

## T2-04

## Micro Diaphragm Pumps (air/gas)

### Typical Flow Curve

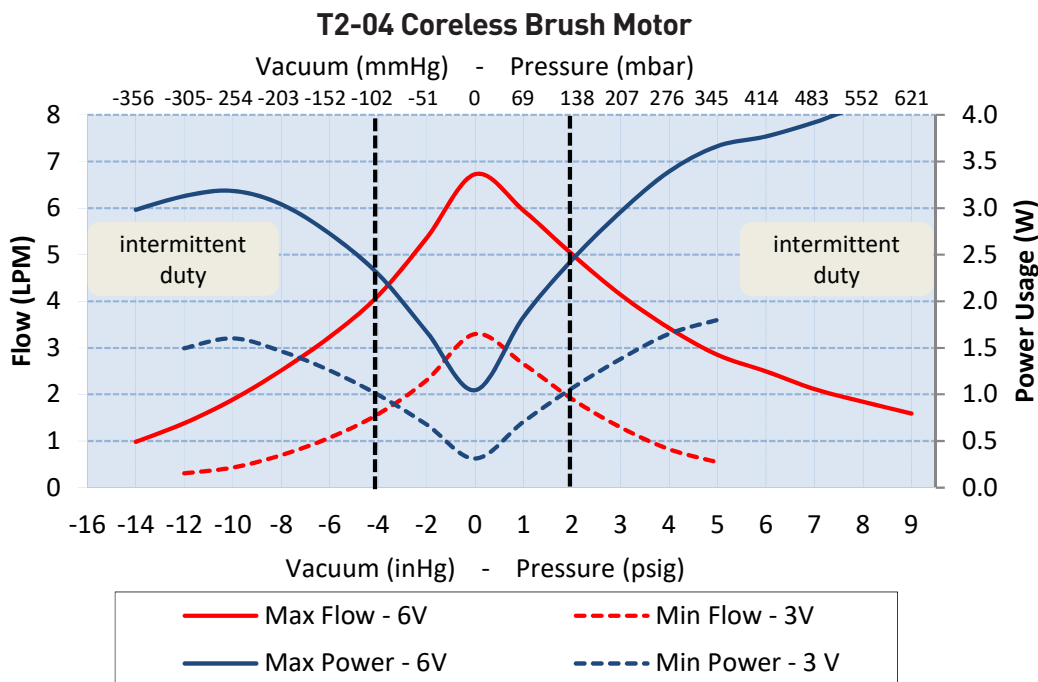

The above graphs represent examples of performance for the pumps series handling air at 800 feet (244M) above sea level at 75° F (24° C). Performance will vary depending on barometric pressure and media temperature.

Curves are representative of standard pump configurations. Pump configurations could be customized for higher or lower flows, depending on specific customer requirements.

Please contact Parker Precision Fluidics Applications Engineering for other considerations

## Sizing and Selection

### T2-04 Series

Coreless Brush Motor



#### Mounting Guidelines:

- Parker recommends using a nylon cable tie with a length of at least 4" (100 mm).

#### Port Connections:

- Barbs are sized for 1/4" ID tubing, 70-80 durometer recommended

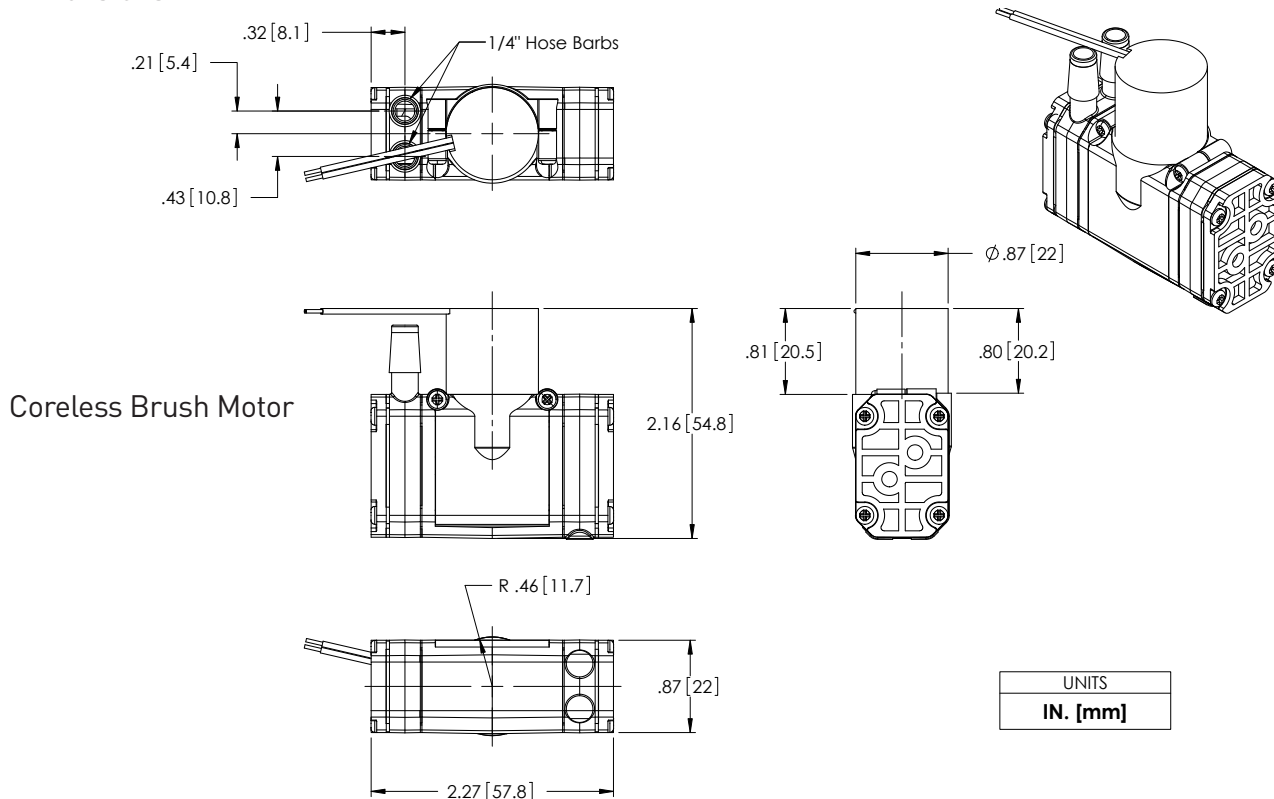
**T2-04****Micro Diaphragm Pumps (air/gas)****Mechanical Integration****Dimensions****Electrical Integration and Motor Control**

If application requires variable flow, motor control options are available, as follows:

**Brush Motor**

2 Wire	Red (+), Black (-)
Wire specification	28 AWG 5" (127 mm) Wire Leads

**Key Things to Remember**

5" (127mm) flying Leads are the standard electrical connection method to the pump. Contact Applications for other connection requirements.

The pump lead wires are non-polarized.

The pump can be controlled by DC voltage or PWM through a control board supplied by the customer. The minimum recommended PWM frequency is 20kHz.

The pump flow and pressure can be controlled by adjusting the input voltage.

The pump is not a pressure holding device. An external check valve is recommended, if there is a pressure holding requirement.

Pump orientation does not affect performance or life.

## T2-04

## Micro Diaphragm Pumps (air/gas)

## Typical Flow Diagram

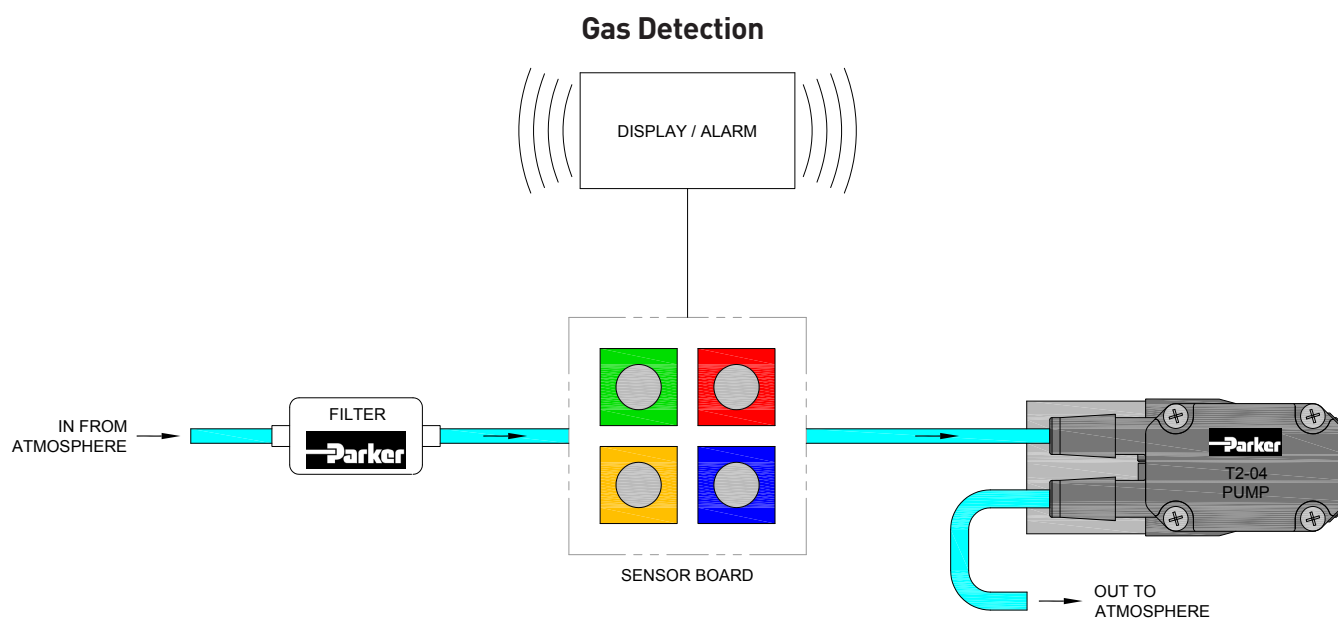

## Chemical Compatibility Chart\*

Chemical	Chemical Compatibility of Wetted Path Materials		
	Neoprene Rubber(CR)	PPA	Silicone
Air	1	1	1
Ozone (1000 ppm)	3	1	1
Oxygen	1	1	2
Ethylene (Ethene)	1	1	4
Acetylene	2	1	3
Propane	1	1	4
Methane	2	1	4
Nitrogen	1	1	1
Carbon Dioxide	1	1	2
Halothane (Up to 5%)	4	1	4

\*The above is an Abbreviated Chemical Compatibility Chart. Please consult factory for details.

## Compatibility Legend

- EXCELLENT  
Minimal or no effect
- GOOD  
Possible swelling and/or loss of physical properties
- DOUBTFUL  
Moderate or severe swelling and loss of physical properties
- NOT RECOMMENDED  
Severe effect and should not be considered

*Note: Consult factory for other gases.*

## T2-04

## Micro Diaphragm Pumps (air/gas)

## Ordering Information

Configuration	Vacuum:		Free Flow	Pressure:		Max Continuous Pressure			Peak Current <sup>1</sup>		Wetted Materials <sup>2</sup>
	LPM @ Load			LPM @ Load							
Part No.	-4 inHg	-2 inHg	0	4 psig	8 psig	Vac inHg	Press psig	Motor Type	VDC	mA	Diaphragm, Valves, Gasket
	-101 mmHg	-50 mmHg		276 mbar	552 mbar						
<b>T4-2HE-06-1SCA</b>	4.1	5.3	<b>6.7</b>	6.0	5.0	-4	2	Coreless Brush	6	425	CR, VMQ, EPDM

1. Peak current draw in continuous operating range 2. CR: Neoprene, VMQ: Silicone, EPDM: Ethylene Propylene Diene Monomer  
Note: Other part number could be available for specific application configurations

Please click on the Order On-line button below (or go to [www.parker.com/precisionfluidics/t4](http://www.parker.com/precisionfluidics/t4)) to configure the T2-04 micro pump for your application.

Serviceable – PPF products are designed for use through the rated life and Parker does not sell replacement parts, nor is it recommended to service these in the field

Note: In addition to Parker's innovative and flexible pump designs, we offer applications engineering expertise to our customers in order to configure and recommend the optimal pump for the application. Contact Parker Applications Engineering to discuss and configure alternate pump configurations to meet your specific application requirements. Providing information on the following requirements will assist us in developing an optimal solution for your application:

- Noise
- Operating Pressure / Vacuum
- Power Consumption
- Life Requirement
- Function in the Application
- Size
- Motor Control
- Media
- Voltage



## Appendix A

All performance data is typical based on standard conditions: 70°F and 14.7 psia (21°C and 1 bar).

1. Duty Dependent. For operation above 122°F (50°C) consult factory
2. Noise is dependent on the configuration and operation of the pump in the application. Parker has the ability to tailor the pump configuration when noise is a critical criterion in the effort to meet the performance requirements of the application. Noise level is tested to Parker protocol P-105.
3. Life rating can vary depending on application and operating conditions.
4. Custom motor options available. Custom motors may require a significant application potential. The standard motors can be configured with a special winding to meet a particular operation point at a specified voltage
5. Current range is dependent on motor type, voltage, pressure/vacuum and flow requirement. Lower levels possible depending on application.
6. Inductance can be used to measure the viability of a component in a device requiring intrinsic safety.
7. Maximum intermittent pressure/vacuum data is a pump capability guideline for applications that go beyond the maximum continuous levels for short periods of time. Please consult customer specific requirements with the factory or Applications Engineering.
8. Pump efficiency is a measure of the flow rate generated per unit of power consumed. Efficiency may change dependent on application and operating condition at free flow.



Parker Hannifin Corporation  
**Precision Fluidics Division**  
 26 Clinton Dr., Unit 103  
 Hollis, NH 03049  
 phone: +1 603 595 1500  
 email: [ppfinfo@parker.com](mailto:ppfinfo@parker.com)  
[www.parker.com/precisionfluidics](http://www.parker.com/precisionfluidics)

## Notes