

BTX-Connect

Miniature Diaphragm Pump



ENGINEERING YOUR SUCCESS.

Innovative solutions for health care success



ENGINEERING **YOUR** SUCCESS.

When you partner with the global leader in motion and control technologies, expect to move your business and the world forward. From miniature solenoid valves to highly integrated automation systems, our innovations are critical to life-saving medical devices and scientific instruments used for drug discovery and pathogen detection. Not to mention, critical to decreasing time to market and lowering your overall cost of ownership. So partner with Parker, and get ready to move, well, anything.



www.parker.com/precisionfluidics 1 603 595-1500

BTX-Connect Miniature Diaphragm Pump

Up to 11 LPM Free Flow



Parker's BTX-Connect pump product line combines best in class diaphragm pump design, innovative 'connected' brushless motor technology, ultra-low vibration, and advanced manufacturing techniques to bring a next-generation solution to next-generation device needs. The BTX-Connect Pump is designed to provide high performance with superior quality and reliability. The options for Motor Control, Single Head, Dual Head, Pressure only, Vacuum only, and Pressure/Vacuum configurations offer a wide range of solutions with the support of Parker's Global Teams.

Applications

- Point of Care Diagnostics
- Negative Pressure Wound Therapy
- Compression Therapy
- Medical Simulation
- Scent Dispersion

Features

- "Connected" brushless motor design with digital communication control and monitoring available
- Fail-safe design with over-current, stall, and over-temperature shut-down
- Optimized pump balancing for ultra-low vibration
- RoHS, REACH, and CE compliant



Product Specifications

Physical Properties

Operating Environment¹:	41 to 122°F (5 to 50°C)
Storage Environment:	-4 to 212°F (-20 to 100°C)
Media:	Air, Nitrogen, Oxygen, and other non-reacting gases
Humidity:	0 - 80% Relative Humidity Non-condensing
Noise Level²:	As low as 45 dB @ 12 in (30 cm) <i>Muffler recommended for additional noise reduction (see accessories)</i>
Pump Assembly Rated Life³:	Brushless Motor - 15,000 Hours
Weight:	Compact BLDC Single Head 4.4 oz (125 g) Compact BLDC Dual Head 5.8 oz (165 g) Slotless BLDC Single Head 7.4 oz (209 g) Slotless BLDC Dual Head 8.4 oz (240 g)

Wetted Materials

Diaphragm:	Long Life - Advanced EPDM
Valves:	EPDM, Advanced EPDM
Pump Head:	PBT

Other materials available upon request

Electrical

Motor Type (DC):	Brushless Slotted, Brushless Slotless
Nominal Motor Voltages⁴:	12 or 24 VDC
Electrical Termination:	Mating Connector: JST PAP-06V-S Pin 1: Tachometer Speed (Blue) Pin 2: PWM or 0-5V Input (White) Pin 3: +DC Voltage Input (Red) Pin 4: -Ground (Black) Pin 5: Digital UART Rx (Brown) Pin 6: Digital UART Tx (Purple)

Pneumatic

Maximum Unrestricted Flow:	Single Head: Up to 6 LPM Dual Head: Up to 11 LPM
Pressure Range:	Continuous Duty: Up to 30 PSIG (2 Bar)
Vacuum Range:	Continuous Duty: Up to -22 inHg (-558 mmHg)
Filtration:	40 microns - recommended

Connect Features

Speed Control Options:	On/Off Control, Factory Set Speed PWM 0-5V Analog Serial UART
Current Limit Shut Down:	Compact BLDC 12V - 1 Amp Compact BLDC 24V - 0.5 Amp Slotless BLDC 12V - 2 Amp Slotless BLDC 24V - 1 Amp
Temperature Limit Shut Down:	Compact BLDC: 90°C Slotless BLDC: 90°C Time before shut down: 2 Seconds
UART Serial Comm:	Pump speed measurement: ±200 RPM Internal Motor Temp: ±10°C Current Measurement: ±50mA Temp and current limits are factory adjustable <i>On/Off only, PWM input, and 0-5Vdc are factory set, see ordering table.</i> <i>Standard on/off configuration only requires DC power and Ground.</i>

BTX-Connect Miniature Diaphragm Pump Typical Flow Curve



BTX-Connect Single Head Typical Performance

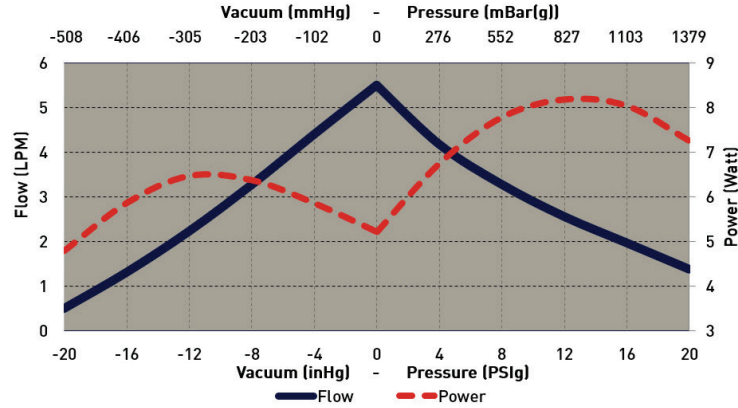

BTX-Connect Dual Head Typical Performance

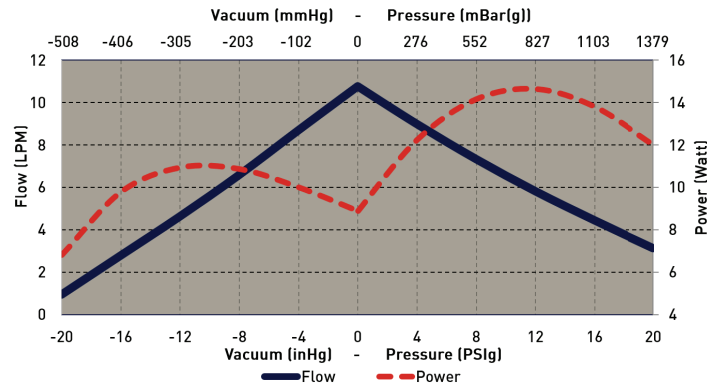

- Dual head performance shown with B2H configuration and pump heads connected in parallel
- Curve shows maximum flow capability with a 0.090" pump offset, which are vacuum or pressure only Pumps capable of alternating pressure and vacuum are available with 0.050" pump offset or less. See ordering table below for a list of available standard options
- Detailed performance specification sheets are available for each part number
- Contact Parker Precision Fluidics Applications Engineering team for other performance options

The user, through its own analysis and testing, is solely responsible for making the final selection of the system and components and assuring that all performance, endurance, maintenance, safety and warning requirements of the application are met. The user must analyze all aspects of the application, follow applicable industry standards, and follow the information concerning the product in the current product catalog and in any other materials provided from a Parker or its subsidiaries or authorized distributor.

The above graphs represent an example of performance for the pump series handling air at 800 feet (244 m) above sea level at 75 degree F (24 C). Performance will vary depending on barometric pressure and media temperature. A variety of configurations can be accommodated to meet application requirements.

Curves are representative of standard pump configurations. Pump configurations could be customized for higher or lower flows depending on specific customer requirements.

Please contact Parker Precision Fluidics Applications Engineering for other considerations.

BTX-Connect Miniature Diaphragm Pump Sizing and Selection

BTX-Connect Single Head
Compact BLDC Motor

B1C



BTX-Connect Single Head
Slotless BLDC Motor

B1S



BTX-Connect Dual Head
Compact BLDC Motor

B2C



BTX-Connect Dual Head
Slotless BLDC Motor

B2S



BTX-Connect Dual Head
High Performance Slotless
BLDC Motor

B2H



Efficiency	Better	Best	Best
Flow Rate	Good	Better	Best
Life	Best - 15,000 Hours	Best - 15,000 Hours	Best - 15,000 Hours
Control	On/Off, Digital, PWM, 0-5V	On/Off, Digital, PWM, 0-5V	On/Off, Digital, PWM, 0-5V
Protection	Reverse Polarity, Temp, Current	Reverse Polarity, Temp, Current	Reverse Polarity, Temp, Current
Cost	Better	Good	Good

Mounting Guidelines:

- Bracket options available for mounting consideration (See *EZ Mount catalog pages*).
- Hole in the center of the bottom housing is for manufacturing only—not to be used for mounting.
- Mounting holes are drilled for #6-20 self-tapping screws with 1/4" (6 mm) thread engagement torque to 4 in-lbs (0.45 N-m).

Port Connections:

- Barbs are sized for 1/8" (3 mm) ID tubing, 70-80 durometer recommended.
- Flow direction is marked on the pump head with arrows.

BTX-Connect Miniature Diaphragm Pump Mechanical Drawings

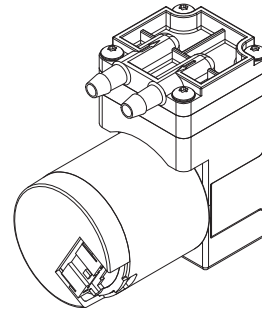
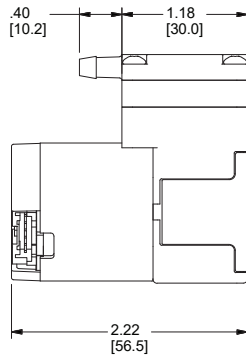
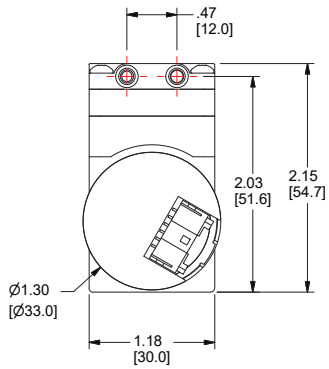

NOTES:
MOUNTING HOLES ARE DRILLED FOR #6-20 SELF-TAPPING SCREWS WITH 1/4" THREAD ENGAGEMENT. [torque to 4 in-lbs.]

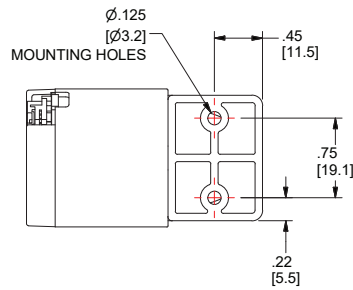

UNITS
IN [mm]

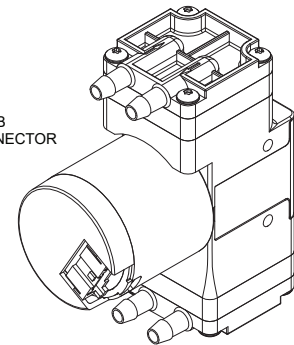
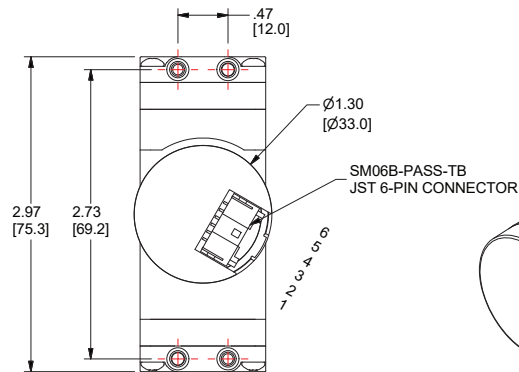
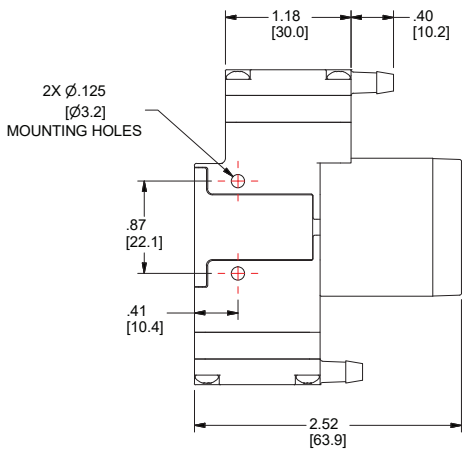

UNITS
IN [mm]

NOTES:
MOUNTING HOLES ARE DRILLED FOR #6-20 SELF-TAPPING SCREWS WITH 1/4" THREAD ENGAGEMENT. [torque to 4 in-lbs.]

PIN OUT	
1	TACH
2	PWM / EVC
3	V+
4	GROUND
5	UART Rx
6	UART Tx

BTX-Connect Miniature Diaphragm Pump Mechanical Drawings

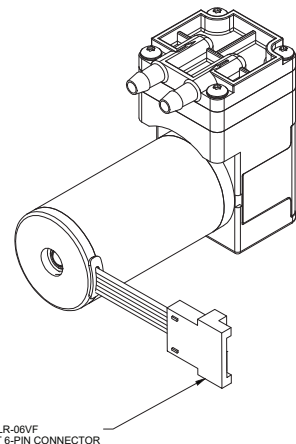
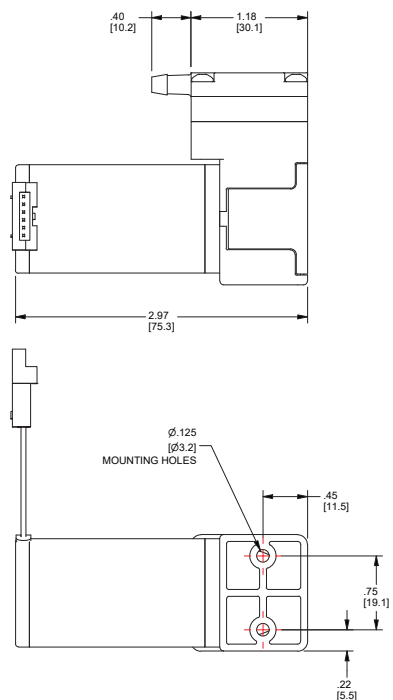
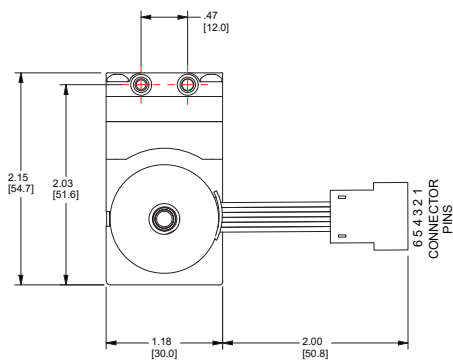

NOTES:
MOUNTING HOLES ARE DRILLED FOR #6-20 SELF-TAPPING SCREWS WITH 1/4" THREAD ENGAGEMENT. [torque to 4 in-lbs.]

UNITS
IN [mm]

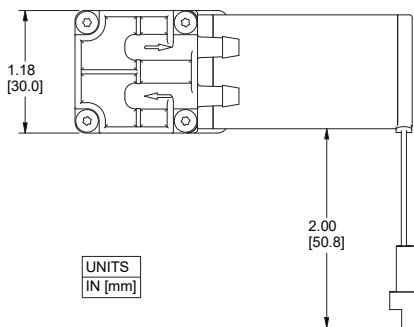
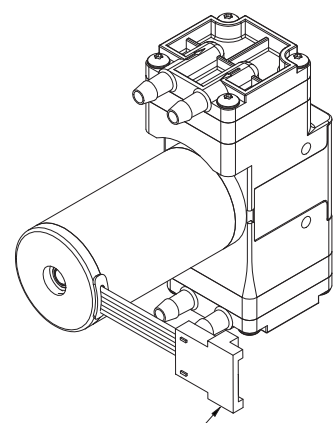
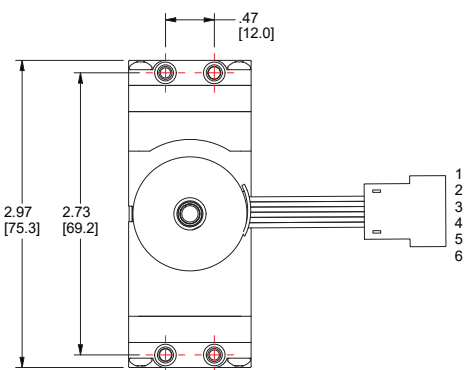
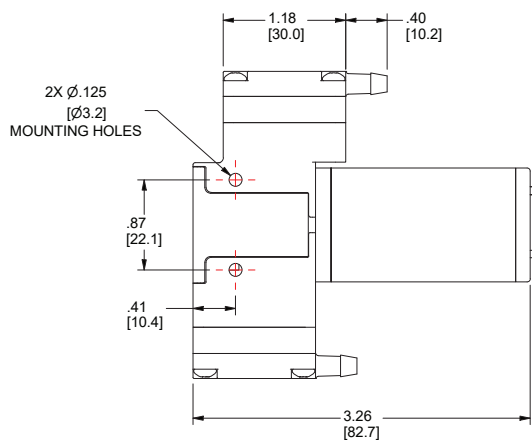

UNITS
IN [mm]

PIN OUT	
1	TACH
2	PWM / EVC
3	V+
4	GROUND
5	UART Rx
6	UART Tx

NOTES:
MOUNTING HOLES ARE DRILLED FOR #6-20 SELF-TAPPING SCREWS WITH 1/4" THREAD ENGAGEMENT. [torque to 4 in-lbs.]

PALR-06VF JST 6-PIN CONNECTOR



BTX-Connect Miniature Diaphragm Pump Typical Flow Diagrams

Negative Pressure Wound Therapy (NPWT)

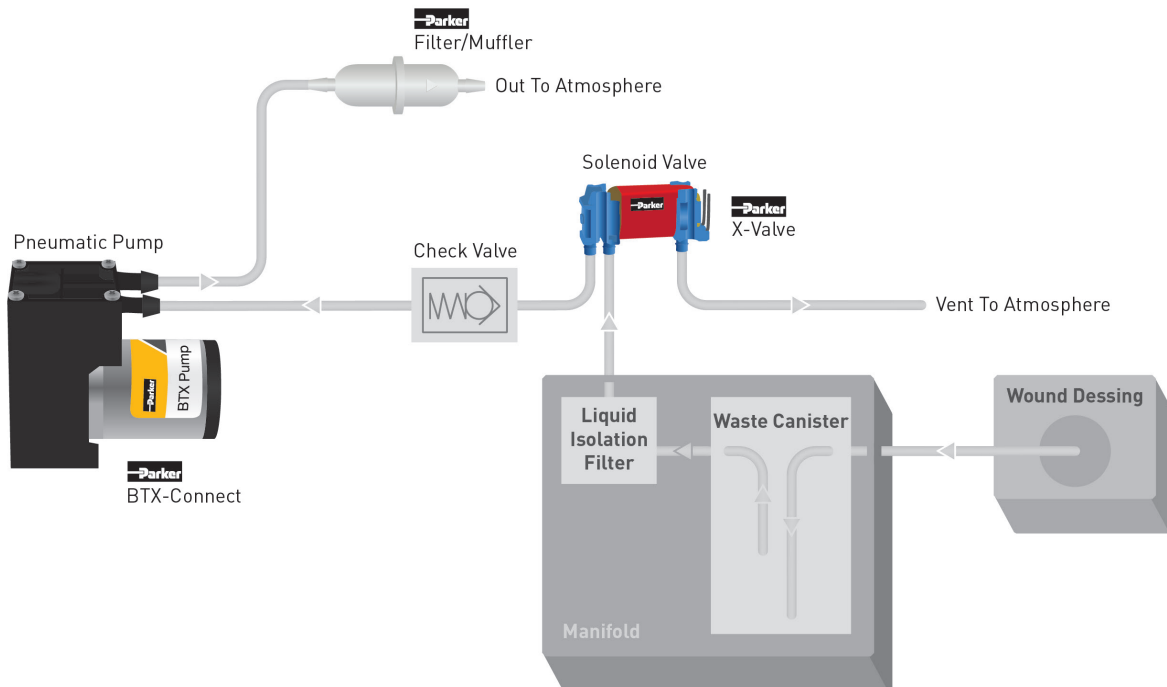

BTX-Connect Miniature Diaphragm Pump Typical Flow Diagram

Compression Therapy Prevention (DVT)

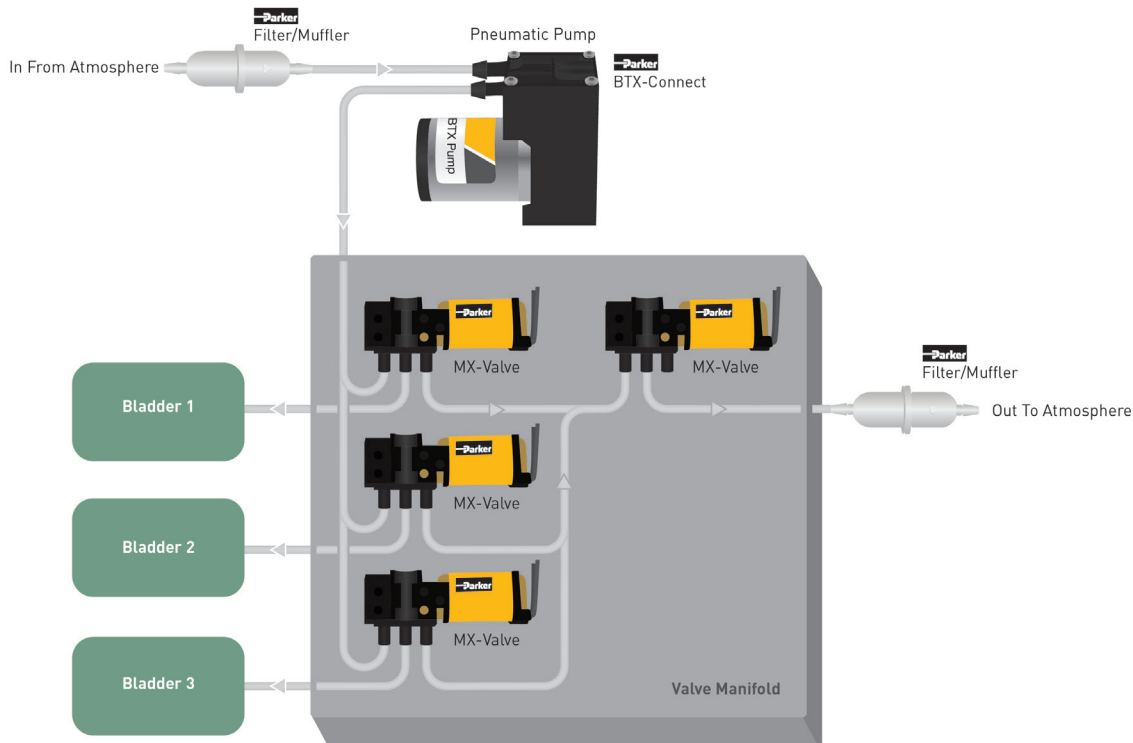

Air-Over-Liquid Flow Control

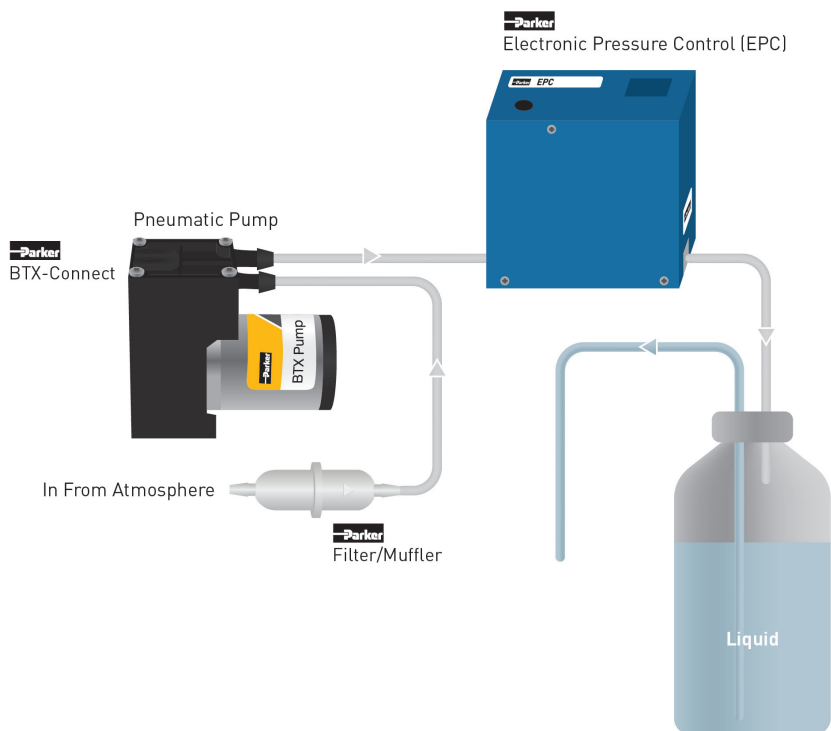

BTX-Connect Miniature Diaphragm Pump CE Compliant

Test	Standard	Test Level
Radiated Emissions	IEC 60601-1-2:2014 EN 61000-6-3:2007/A1:2011	Class B
DC Mains Conducted Emissions	IEC 60601-1-2:2014	Class B
ESD	IEC 60601-1-2:2014 EN 61000-4-2	+/- 8kV couplings planes +/- 8kV contact, +/- 15kV air
RFI - Amplitude Modulated	IEC 60601-1-2:2014 EN 61000-4-3	80-2700 MHz @ 3V/m 1kHz 80%AM
Proximity fields from RF wireless communication	IEC 60601-1-2:2014 EN 61000-4-3	Full table of tested conditions available in the lab report
Power-Frequency Magnetic Field	IEC 60601-1-2:2014 EN 61000-4-8	30A/m

Electrical Integration and Motor Control

Motor Electrical Connection

Integrated Electrical Connector	Male pin JST PALR - 06VF
Recommended Mating Connector	Manufacturing: JST Housing Part Number: PAP-06V-S Terminal Part Number: SPHD-001T-PO.5
Recommended Wire	22 AWG Stranded Wire

BTX- Connect Motor Control Options

The motor control feature is factory selected in 4 speed control modes: On/Off control, PWM input, 0-5Vdc input or UART Serial port mode. These modes are described in detail in the Application Notes section. The Tachometer signal is always enabled.

*The controller utilizes the on-board micro-controller clock, it is not a real time clock.

Speed Control Methods

Stored Speed Setting	With this configuration, the pump speed is factory set, only ground and input voltage must be supplied. The speed can only be adjusted using UART command with this mode.
PWM Input	A PWM signal input is provided on the speed input to change pump speed. When using this mode, the pump is set to 100% speed if the input is floating.
Analog 0-5Vdc Control	0-5 Volt DC signal is applied to control speed. When using this mode, the pump is set to 0% speed if the input is floating.
UART Control	The user will activate the pump and adjust the speed of the pump using the UART serial port channel, the pump will be off until the host sends a UART speed command.

BTX-Connect Miniature Diaphragm Pump Electrical Integration and Motor Control

PWM Control Electrical Details

On Board Motor Circuit	1k Ω to +5VDC weak pull-up enabled on micro controller (Approximately 150-200 microAmp) 5.1VDC Zener diode limits voltage to micro-controller. Controller measures 10 samples 5ms apart to filter input signal. (50ms time between speed updates)
User Control Circuit	User must pull the 5 VDC signal to ground, 0.8 VDC low threshold. MOSFET transistor circuit with external pull-up resistor is recommended as shown in example below.
Control Range	0-95% duty cycle. 96-100% will operate motor at full speed Recommended to only supply PWM signal of 0-95% for speed control.

User PWM Control Circuit Example

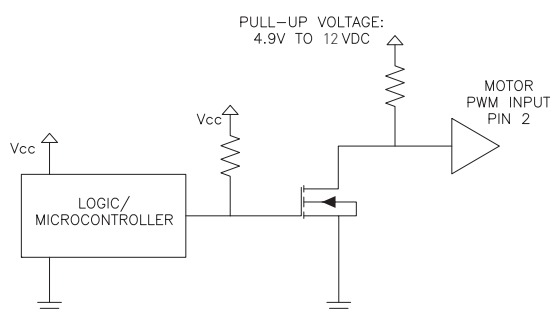

0-5VDC Control Electrical Details

On Board Motor Circuit	1k Ω to micro controller analog input. 5.1VDC Zener diode limits voltage to micro-controller. If the input is disconnected (floating input) it is normal for the pump to operate very slowly, less than 100 RPM or completely off. Controller measures 10 samples 5ms apart to filter input signal. (50ms time between speed updates)
User Control Circuit	User must supply 0 to 5 VDC analog signal for control

Tachometer Electrical Details

Speed Signal Output	The feature is always on, regardless of speed control mode
Compact BLDC Signal	4 Pulses per rotation of the pump
Slotless BLDC Signal	1Pulse per rotation of the pump
On Board Motor Circuit	0 to 5 VDC square wave signal Low signal will be < 0.6VDC, High will be > 4.3VDC

Do not connect motor electrical connector harness while power is applied (Hot Plugging). Arching in the connector may damage UART electronics.

BTX-Connect Miniature Diaphragm Pump Application Notes

UART Electrical Details

UART Voltage	5Vdc TTL UART Voltage
On Board Motor Circuit	UART Connection to PIC18F micro-controller
User Control Circuit	Recommended to use isolation, such as optocouplers motor electronics from user electronics. Parker uses a Microchip MCP2200 UART to USB transceiver IC and confirms it is compatible with the BTX-Connect Motor.
Power Supply and Ground Recommendations	It is possible to power the motor micro-controller through the UART Rx pin. Care should be taken to avoid this possibility. If voltage is provided to the Motor Rx pin while Ground is connected and Vin is disconnected the internal micro-controller may be parasitically powered. This is due to current flowing through the internal Schottky protection diodes in the micro-controller. This can cause the micro-controller to stay powered on when the power is cycled, or it may cause the micro-controller to enter a brown-out condition. It is recommended to remove power from the Rx pin in this condition or low-side switch the Ground to the pump.

Connect Features and Instructions

The BTX-Connect offers many methods to control the pump, this is configured by the factory. However, in any configuration, the serial UART port can be accessed for pump information.

State Diagram

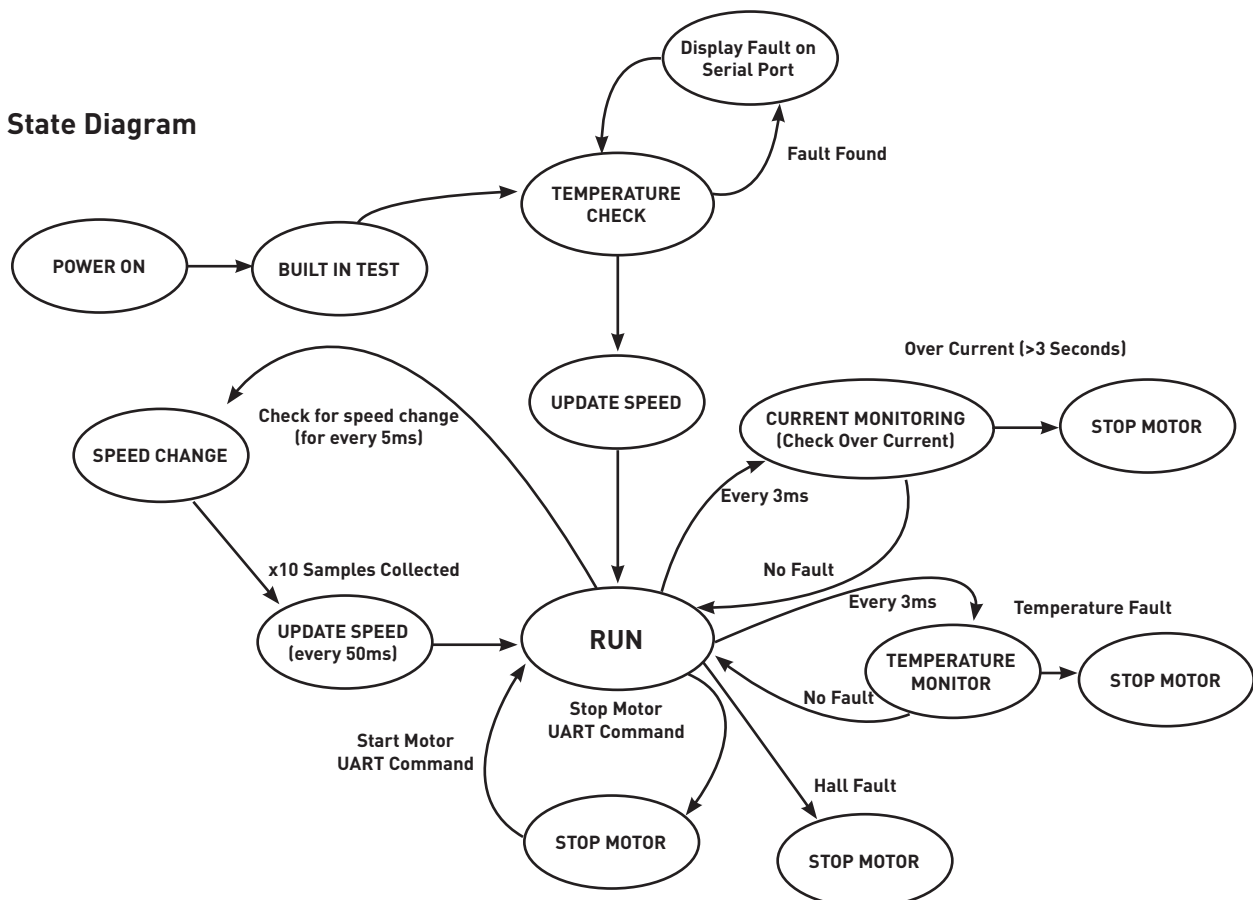

BTX-Connect Miniature Diaphragm Pump Serial UART Details

The BTX with Connect technology includes a UART Serial port that is available regardless of speed control mode. Communication with the pump allows a user to monitor pump performance and pump health. This provides more detail to the hosts system for more integrated pump management and error handling.

UART Configuration

Electrical Signal	5Vdc TTL Level*
Baud Rate	9600 bps
Data Bits	8
Parity	None
Stop Bits	1
Flow Control	None
Timing	Allow > 20ms delay between messages

*For integration with RS232 or USB, a transceiver/converter is required

UART Syntax

1 Byte	4 Bytes	1 Byte	4 Bytes	1 Byte
\$	GETS	,	TACH	#
Starting Flag	Command Type	Comma Selector	Command	Ending Flag

1 Byte	4 Bytes	1 Byte	4 Bytes	1 Byte	1-5 Bytes	1 Byte
\$	CMDS	,	PWMS	,	75	#
Starting Flag	Command Type	Comma Selector	Parameter Name	Comma Separator	Input Parameter	Ending Flag

*Each message from the motor will end with a carriage return (ASCII: 0D)

UART Command Set	Command Sent to Motor	Response from Motor	Description
Temperature Fault at Start-Up	No Command Required; Only at pump startup	\$Temperature Fault: xxx#	If the motor controller temperature exceeds the allowed limit, the pump will not start. This is continuously monitored until the fault is cleared and the motor will start. The pump will continuously send this response until the fault is cleared.
Pump Heartbeat Message	No Command Required	\$HB#	Pump will report a heartbeat message over UART every 30 seconds
Invalid Message Response	Incorrect Command or Syntax	\$CMD: Error#	Response if an incomplete message is sent to the pump
Control Commands	Command Sent to Motor	Response from Motor	Description
Set Pump Speed	\$CMDS,PWMS,500#	\$ACK,PWMS,500#	Set PWM Duty Cycle, <1-100%>, 505 = 50.5% 1000 = 100.0%
Stop Pump	\$CMDS,MSTP#	\$ACK,MSTP#	Motor will stop
Restart Pump	\$CMDS,MRST#	\$ACK,MRST#	Pump will restart, will allow restart fault

BTX-Connect Miniature Diaphragm Pump Serial UART Details

Status Commands	Command Sent to Motor	Response from Motor	Description
Read Approx. Current	\$GETS,CURR#	\$STAT,CURR,1100#	Pump reports approximate average motor current, reported in mA
Read Approx. Temp.	\$GETS,TEMP#	\$STAT,TEMP,50#	Pump reports approximate temperature on motor controller, reported in Celsius
Read Pump Speed	\$GETS,TACH#	\$STAT,TACH,3200#	Pump reports approximate pump speed in RPM (integer value 0 - 65530)
Read Set PWM Duty	\$GETS,SDTY#	\$STAT,SDTY,50#	Pump will report output duty cycle (regardless of control method) (integer value 0 - 1000), 505 = 50.5% 1000 = 100.0%
Read Pump Health	\$GETS,HLTH#	\$STAT,HLTH,Normal#	Pump will report "Normal" if no fault has occurred
		\$STAT,HLTH,OverCurrent#	Pump will report "Over Current" if preset current limit has been reached and pump has stopped
		#STAT,HLTH,OverTemperature#	Pump will report "OverTemperature" if preset temperature limit has been reached and pump has stopped
		\$STAT,HLTH,UnknownHallState#	Pump will report "UnknownHallState" if the hall pattern detected is undefined, for example this may occur if a hall sensor has failed

History Command	Command Sent to Motor	Response from Motor	Description
Read Pump History	\$GETP,HIST#	\$STAT,CRED,xxx#	Pump will report the number of times a current fault has occurred (integer value 0 - 255)
		\$STAT,TRED,xxx#	Pump will report the number of times a temperature fault has occurred (integer value 0 - 255)
		\$STAT,HOUR,xxxxx#	Pump will report number of operating hours for the pump (integer value 0 - 22500); approximate accuracy for comparison use Pump stores time in increments of 10 seconds, upon start-up a 10 second increment is immediately stored (frequent on/off will effect time accumulation). Due to limitations with flash storage read/writes, this value is capped at 22,500 hours.
		\$STAT,CYCL,xxxxxxx#	Pump will report number of on/off power cycles for the pump (integer value 0 - 1500000) This value is capped at 1.5 Million cycles.

BTX-Connect Miniature Diaphragm Pump Application Notes Chemical Compatibility Chart*

BTX-Connect Chemical	Chemical Compatibility of Wetted Path Materials	
	AEPDM	PBT
Air	1	1
Ozone (1000 ppm)	1	1
Oxygen	1	1
Ethylene (Ethene)	1	1
Methane	4	2
Nitrogen	1	1
Carbon Dioxide	2	1
Acetone (Vapor/Cleaning)	1	1(5%), 3(100%)

Compatibility Legend

- EXCELLENT**
Minimal or no effect
- GOOD**
Possible swelling and/or loss of physical properties
- LIMITED**
Moderate or severe swelling and loss of physical properties
- NOT RECOMMENDED**
Severe effect and should not be considered

Note: Consult factory for other gases.

*The above is an Abbreviated Chemical Compatibility Chart. Please consult factory for details.

Pulse Width Modulation (PWM)

Pulse-width modulation is a commonly used technique for controlling DC motors.

The average value of the voltage fed to the motor is controlled by turning a switch between the voltage supply and the motor on-and-off at a fast pace. The longer the switch is on compared to the off time, the higher the power supplied to the motor.

The PWM switching frequency varies for different types of devices, and is selected based on how it affects the device. For example, some applications require a faster switching frequency to prevent audible noise or electrical noise.

The term duty cycle describes the ratio of on-time to the period (one complete on-and-off cycle). Duty cycle is normally expressed as a percentage of on-time, 100% being full-power and 50% being half-power.

The advantage of PWM is the reduction of power-loss due to switching versus other control methods. Parker Hannifin recommends controlling the pump using 15kHz - 20 kHz frequency range.

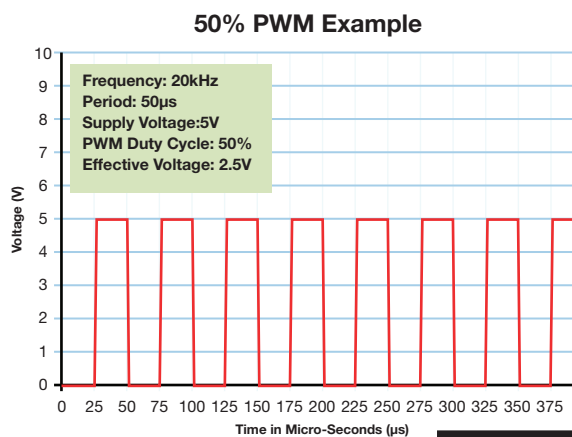
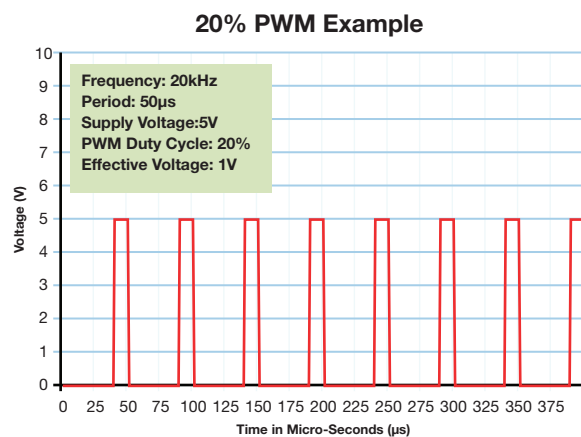

BTX-Connect Miniature Diaphragm Pump Accessories Information

A **Filter-Muffler** is always recommended in the air inlet or outlet to reduce noise and risk of debris that may affect pump performance. Parker recommends 40 micron or better filtration to be used with this pump series.

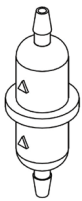

P/N: 00492-15
(10 micron Filter)

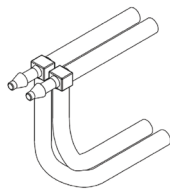

P/N: 01881-KT
(Parallel Tubing)

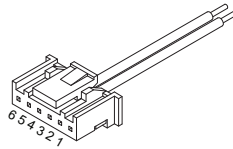

P/N: 02040-10
(2-Wire Harness)

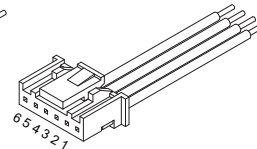

P/N: 02042-10
(4-Wire Harness)

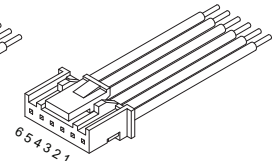

P/N: 02043-10
(6-Wire Harness)

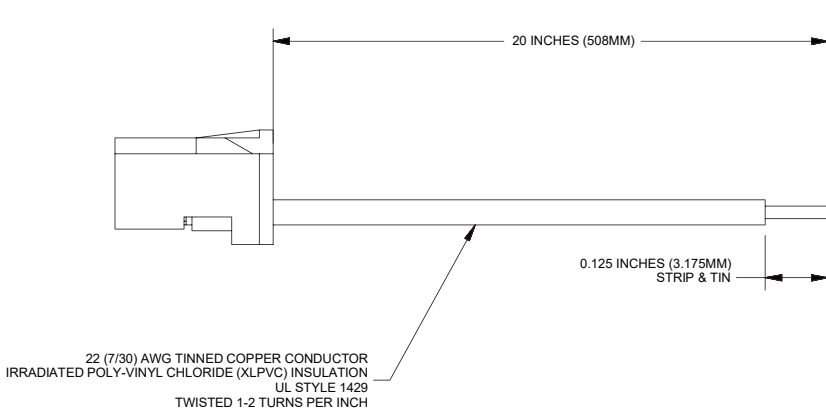

Connector Pin-out

	Color	Function
1	Blue	Tachometer
2	White	Speed Input
3	Red	Power V+
4	Black	Ground V-
5	Brown	UART Rx
6	Violet	UART Tx

BTX-Connect Miniature Diaphragm Pump

EZ Mount available

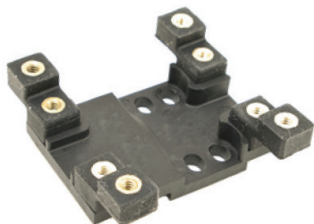

EZ Mount provides ease of installation and effective control of vibration transfer. EZ Mount was designed to mount easily to the Precision Fluidic BTX Family of diaphragm pumps.

Features

- Isolation feet on the EZ mount can be rotated in any one of three ninety-degree planes and is designed for top-down or bottom-up mounting providing simple installation.
- EZ Mount was designed to minimize weight added to the pump assembly. Approximate weight is: 0.63 oz (18 g).
- Effectively absorbs vibration to minimize most vibration-induced noise and vibration transfer into an instrument.
- Designed to keep height and size to a minimum.
- All necessary hardware to attach to a BTX pump is included.

Physical Properties

Operating Environment:

41 - 158°F (5 - 70°C)

Humidity:

0 - 95% Relative Humidity

Base Plate:

Noryl GTX830

Feet:

Silicone

Feet Insert:

Brass

Hardware:

Zinc-Plated Steel

- Isolation Feet are available in either threaded or thru-hole clearance for standard #4-40 or #6-32 (M3 for clearance hole only).

Style A Dimensions

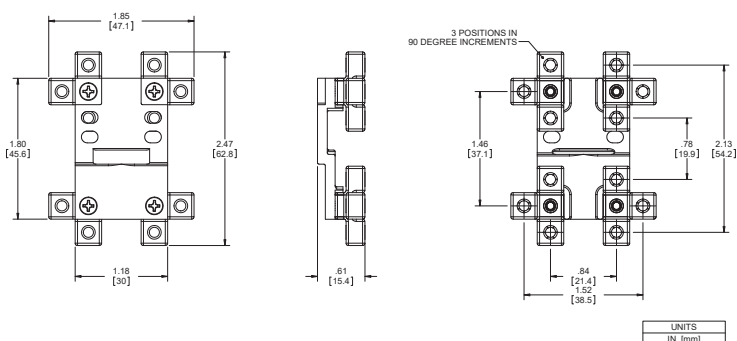

Style B Dimensions

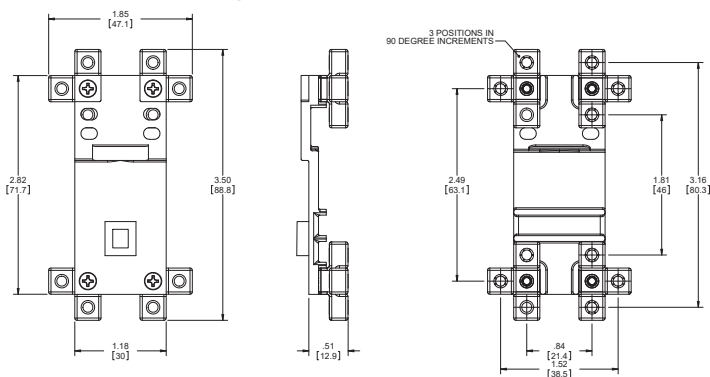

EZ Mount for BTX with Compact Motor Single and Dual Head (B1C and B2C)

Part Number	Style	Feet Type
00328-10-A45S	A	#4-40 Threaded
00328-10-B45S	A	#4 Clearance
00328-10-D45S	A	#6-32 Threaded
00328-10-C45S	A	#6 / M3 Clearance

EZ Mount for BTX with Slotless Single Head (B1S and B1H)



Part Number	Style	Feet Type
01074-10-A45S	B	#4-40 Threaded
01074-10-B45S	B	#4 Clearance
01074-10-D45S	B	#6-32 Threaded
01074-10-C45S	B	#6 / M3 Clearance

EZ Mount for BTX with Slotless Dual Head (B2S and B2H)



Part Number	Style	Feet Type
00329-10-A45S	B	#4-40 Threaded
00329-10-B45S	B	#4 Clearance
00329-10-D45S	B	#6-32 Threaded
00329-10-C45S	B	#6 / M3 Clearance



BTX-Connect Miniature Diaphragm Pump Ordering Information

Configuration	Voltage	Motor Control	Part Number	-16 inHg -406 mmHg	-12 inHg -305 mmHg	-8 inHg -203 mmHg	-4 inHg -102 mmHg	0 Free Flow	4 PSIg 276 mbar	8 PSIg 552 mbar	12 PSIg 827 mbar	16 PSIg 1103 mbar
B1C BTX-Connect Single Head with Compact BLDC 	12	On/Off	B1C-050F12AN-00	0.4	1.1	1.8	2.5	3.3	2.7	2.1	1.6	1.1
	12	PWM	B1C-050F12AN-03	0.4	1.1	1.8	2.5	3.3	2.7	2.1	1.6	1.1
	24	On/Off	B1C-050F24AN-00	0.4	1.1	1.8	2.5	3.3	2.7	2.1	1.6	1.1
	24	PWM	B1C-050F24AN-03	0.4	1.1	1.8	2.5	3.3	2.7	2.1	1.6	1.1
	12	On/Off	B1C-070P12AN-00	-	-	-	-	4.5	3.5	2.7	2.0	1.2
	12	0-5Vdc	B1C-070P12AN-02	-	-	-	-	4.3	3.1	2.5	1.8	1.2
	12	On/Off	B1C-090P12AN-00	-	-	-	-	5.5	4.5	3.5	2.8	2.2
	12	PWM	B1C-090P12AN-03	-	-	-	-	5.5	4.5	3.5	2.8	2.2
	24	On/Off	B1C-090P24AN-00	-	-	-	-	5.5	4.5	3.5	2.8	2.2
	24	0-5Vdc	B1C-090P24AN-02	-	-	-	-	6.1	4.9	4.0	3.2	2.5
	12	On/Off	B1C-090V12AN-00	1.5	2.5	3.5	4.7	5.8	-	-	-	-
	12	0-5Vdc	B1C-090V12AN-02	1.2	2	3	4.1	5.2	-	-	-	-
	12	PWM	B1C-090V12AN-03	1.5	2.5	3.5	4.7	5.8	-	-	-	-
	24	On/Off	B1C-090V24AN-00	1.5	2.5	3.5	4.7	5.8	-	-	-	-
	24	PWM	B1C-090V24AN-03	1.5	2.5	3.5	4.7	5.8	-	-	-	-
	B1S BTX-Connect Single Head with Slotless BLDC 	12	On/Off	B1S-090P12AN-00	-	-	-	-	4.8	3.9	3.1	2.5
24		On/Off	B1S-090P24AN-00	-	-	-	-	4.8	3.9	3.1	2.5	2.0
B2C BTX-Connect Dual Head with Compact BLDC 	12	On/Off	B2C-050F12AN-00	0.4	1.7	2.6	3.8	5.1	4	3.2	2.3	1.1
	12	PWM	B2C-050F12AN-03	0.4	1.7	2.6	3.8	5.1	4	3.2	2.3	1.1
	24	On/Off	B2C-050F24AN-00	0.4	1.7	2.6	3.8	5.1	4	3.2	2.3	1.1
	24	PWM	B2C-050F24AN-03	0.4	1.7	2.6	3.8	5.1	4	3.2	2.3	1.1
	12	On/Off	B2C-070P12AN-00	-	-	-	-	8.2	6	4.4	3.0	2.0
	12	On/Off	B2C-090V12AN-00	2.2	3.5	5.4	7.5	9.5	-	-	-	-
	12	PWM	B2C-090V12AN-03	2.2	3.5	5.4	7.5	9.5	-	-	-	-

BTX-Connect Miniature Diaphragm Pump Ordering Information

Configuration	Voltage	Motor Control	Part Number	-16 inHg -406 mmHg	-12 inHg -305 mmHg	-8 inHg -203 mmHg	-4 inHg -102 mmHg	0 Free Flow	4 PSIg 276 mbar	8 PSIg 552 mbar	12 PSIg 827 mbar	16 PSIg 1103 mbar
B2S BTX-Connect Dual Head with Slotless BLDC 	12	On/Off	B2S-050F12AN-00	0.8	1.9	2.9	4.1	5.3	4.3	3.5	2.7	2.0
	24	On/Off	B2S-050F24AN-00	0.8	1.9	2.9	4.1	5.3	4.3	3.5	2.7	2.0
	12	On/Off	B2S-090P12AN-00	-	-	-	-	9.0	7.2	5.7	4.5	3.3
	24	On/Off	B2S-090P24AN-00	-	-	-	-	9.0	7.0	5.7	4.3	3.2
	12	On/Off	B2S-090V12AN-00	2.2	3.8	5.7	7.6	9.3	-	-	-	-
B2H BTX-Connect Dual Head with High Performance Slotless BLDC 	12	On/Off	B2H-050A12AN-00	1.6	2.9	4.2	5.7	7.2	5.8	4.8	3.9	3.0
	12	On/Off	B2H-090V12AN-00	2.8	4.6	6.6	8.7	10.5	-	-	-	-
	12	On/Off	B2H-090R12AN-00	-	-	-	-	10.7	8.9	7.3	5.8	4.4

Accessories Ordering Table

Part No.	Description	Comments
02040-10	2 Pin Wire Harness 20" (508mm) Long	2 Pin wire harness for on/off control only
02042-10	4 Pin Wire Harness 20" (508mm) Long	4 Pin wire harness for speed control and tachometer output
02043-10	6 Pin Wire Harness 20" (508mm) Long	6 Pin wire harness required for UART
00492-15	Filter-Muffler	Filter to 10 microns. Not included with pump
01881-KT	Tubing Assembly	As needed for parallel flow. Not included with pump

BTX Part Number Description (see Appendix A comment 9)

B	1	C	-	090	P	12	A	N	-	00
Model	Pump Heads	Motor Type	Pump Offset	Diaphragm Configuration	Voltage	Material	Tubing	Special		
B - BTX	1 - Single Head	C - Compact	050 - 0.050" Offset	F - Universal Pressure & Vacuum	12 - 12 Vdc	A - 80D AEPDM Diaphragm & low noise Valves	N - None	00 - Factory set speed		
	2 - Dual Head	S - Slotless	070 - 0.070" Offset	P - Pressure Only	24 - 24 Vdc	B - 80D AEPDM Diaphragm & 80D Valves	P - Parallel (dual head only)	01 - Digital UART speed control		
		H - High Performance Slotless	090 - 0.090" Offset	V - Vacuum Only			S - Series (dual head only)	02 - Analog 0-5 Vdc		
				A - Universal Pressure & Vacuum (High Compression Chamber)				03 - PWM speed control		
				R - Pressure Only (High Compression Chamber)						
			Y - Vacuum Only (High Compression Chamber)							



BTX-Connect Miniature Diaphragm Pump Ordering Information

Please refer to sizing and selection chart for identifying which one will fit your application

Please click on the Order On-line button below (or go to www.parker.com/precisionfluidics/BTX-Connect) to configure your BTX-Connect Pump.

Serviceable – PPF products are designed for use through the rated life and Parker does not sell replacement parts, nor is it recommended to service these in the field

Note: In addition to Parker's innovative and flexible pump designs, we offer applications engineering expertise to our customers in order to configure and recommend the optimal pump for the application. Contact Parker Applications Engineering to discuss and configure alternate pump configurations to meet your specific application requirements. Providing information on the following requirements will assist us in developing an optimal solution for your application:

- Noise
- Operating Pressure / Vacuum
- Power Consumption
- Life Requirement
- Size
- Motor Control
- Media
- Voltage



Parker Hannifin Precision Fluidics Division reserves the right to make changes. Drawings are for reference only.

Appendix A

All performance data is typical based on standard conditions: 70°F and 14.7 psia (21°C and 1 bar).

1. Duty Dependent. For operation above 122°F (50°C) consult factory
2. Noise is dependent on the configuration and operation of the pump in the application. Parker has the ability to tailor the pump configuration when noise is a critical criterion in the effort to meet the performance requirements of the application. Noise level is tested to Parker protocol P-105.
3. Life rating can vary depending on application and operating conditions.
4. Custom motor options available. Custom motors may require a significant application potential. The standard motors can be configured with a special winding to meet a particular operation point at a specified voltage
5. Current range is dependent on motor type, voltage, pressure/vacuum and flow requirement. Lower levels possible depending on application.
6. Inductance is an indicator of induced voltage with change in current and it is a key parameter to enable customers' low energy intrinsic safety systems
7. Maximum intermittent pressure/vacuum data is a pump capability guideline for applications that go beyond the maximum continuous levels for short periods of time. Please consult customer specific requirements with the factory or Applications Engineering.
8. Pump efficiency is a measure of the flow rate generated per unit of power consumed. Efficiency may change dependent on application and operating condition at free flow.
9. Part number description for reference only, not all configurations are available or configurable. Contact Parker Precision Fluidics Applications Engineering team for other performance options.

BTX-Connect Miniature Diaphragm Pump

Serving a broad spectrum of life science, air quality, and process instrumentation OEM fluidic needs



Providing Pressure and Vacuum:
Broad range of diaphragm pumps for Gas and Liquid



Gas Flow Control:
High to Low Flow Proportional Valves



On/Off & Channel Selection Capabilities:
Gas and Liquid Solenoid Valves



High Precision Thermal Flow Control:
Mass Flow Controllers and Meters

Learn More at: discover.parker.com/BTX-Connect

Below are some common specifications that are helpful to have on hand to accelerate your product selection:

- Gas Type
- Maximum Flow Rate
- Inlet and Outlet Pressures
- Operating Temperature
- Standard Reference Conditions
- Process Connection Size and Type
- Set Point Signal
- Digital Communication Protocol Preferences

For more information call +1 603 595 1500 or email ppfinfo@parker.com

Visit www.parker.com/precisionfluidics

Recommendations on application design and material selection are based on available technical data and are offered as suggestions only. Each user should conduct their own tests to determine the suitability for their own use. Parker offers no express or implied warranties concerning the form, fit, or function of a product in any application.

