

Data sheet | Technical description and installation instructions

Document number: DB-KU-100085-3

From firmware version 12

Creation date: December 2019



Density sensor DGF-I1



Contents

General information on the data sheet	3
Safety instructions	3
Product specification	4
Installation, commissioning and uninstallation	5
Cleaning and repair	8
Disposal	8
Product specification	9



General information on the data sheet

Usage and storage



- This data sheet is an integral part of the density sensor.
- The data sheet must be stored near the location of use.
- If the density sensor is passed on to third parties, the data sheet or relevant contents must be passed on to them, too.
- Read the data sheet carefully.
- We reserve the right to make changes at any time.

Document function

The data sheet provides information about safe use and installation of the density sensor.

Symbol Description

The following symbols are used within the data sheet to indicate hazardous situations and to mark instructions for action:

Symbol	Description
	Failure to avoid this situation will result in serious or fatal injury.
	Information on procedures and other facts, with no risk of personal injury.
	Single step
1. / 2. / 3.	Series of steps

Safety instructions

Designated use

- The density sensor is exclusively intended for measuring the density of gases. Only permitted media are allowed.
- Non-designated use can compromise safety. The manufacturer is not liable for damage caused by improper or non-designated use.

Requirements for personnel

- The density sensor may only be installed and operated by qualified personnel.

Operational safety

- The operator is responsible for the fault-free operation of the density sensor.
- Only operate the density sensor in proper technical condition.
- In the event of elevated media temperatures, ensure full protection against contact to prevent burns.
- Unauthorized modifications or repairs to the density sensor are not permitted and can lead to unforeseeable dangers.
- Observe legal guidelines for media and area of application.
- Check whether the sensor can be used for the intended purpose in approval-related areas (e.g. hygiene regulations, explosion protection, pressure equipment safety).
- Observe the safety data sheet of the medium to be measured.

Product safety

- The density sensor is compliant with the guidelines listed in the EU Declaration of Conformity. TrueDyne Sensors AG confirms this by affixing the CE mark to the density sensor.



Product specification

Overview

The density sensor DGF-I1 was designed to determine the density of gases and the resulting measured variables, e.g. the concentration of binary gas mixtures. This is done with a micromechanical system (MEMS) with an oscillator in the form of a tuning fork as well as a temperature sensor and a pressure sensor. The sensors are mounted on a circuit board and surrounded by a compact metal housing. The density sensor is screwed directly into a gas line or into a gas tank via an integrated connection. A filter is built into the density sensor to protect it from dirt.

If there is medium in the density sensor, the density of the medium is determined by measuring the resonance frequency of the tuning fork, measuring the temperature and measuring the pressure.

The measured values are then fed to the higher-level system as a signal via an RS485 interface (inspired by Modbus RTU). A Modbus command protocol is used for this purpose.

Density measurements in the range 0...19 kg/m³ are thus possible with a measuring rate of 10 Hz (10 measured values per second).

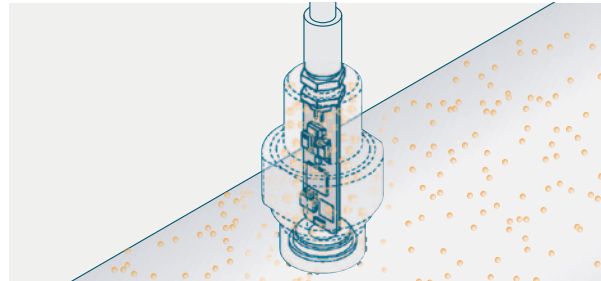

Operating principle: DGF-I1

MEMS oscillator

The MEMS oscillator, a vibronic microsystem, is the heart of the measuring system and serves to generate sensor signals in the overall system. The key component of this microsystem is a tuning fork, which is piezoelectrically vibrated. The tuning fork is mounted in a holder and surrounded by a gas-permeable housing to protect it against mechanical influences.

Density measurement

The density sensor uses both the MEMS oscillator and the pressure and temperature sensor to measure density. During density measurement, the tuning fork is surrounded by the medium to be measured and is set vibrating by the associated circuit.

The resulting resonance frequency of the tuning fork depends on the density of the surrounding medium and

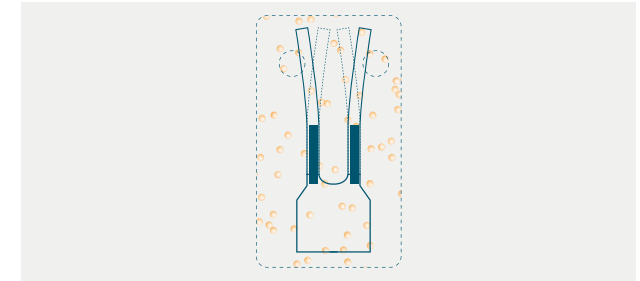

Measuring principle: MEMS oscillator

is also read by the circuit of the MEMS oscillator. The higher the medium density, the lower the resonance frequency. The resonance frequency is thus a function of the medium density.

Application range

The density information from the density sensor can be used directly and indirectly. Product quality can be determined by using the density value directly, while indirect use on the basis of tables and calculation algorithms makes it possible, for example, to determine the concentration of binary gas mixtures.

The density sensor can be used in the following applications, among others:

- Monitoring of welding gas mixtures.
- Monitoring of gas mixtures for food packaging.
- Monitoring of clean gases.



Product design

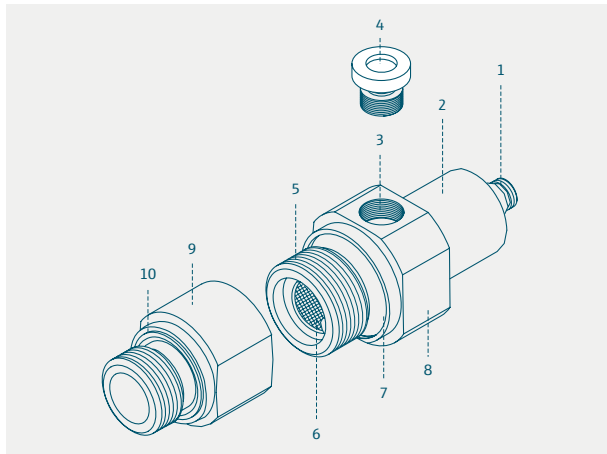

Product design: density sensor DGF-I1

- 1 Electrical interface: M8 connection, 4-pin
- 2 Housing
- 3 Outlet G1/8" thread
- 4 Sealing plug G1/8"
- 5 Fluidic interface: M22×1.5 thread
- 6 Filter fitted with circlip and spring washer
- 7 Sealing ring for M22×1.5 thread
- 8 Support surface for fork wrench (27 mm)
- 9 Adapter for fluidic interface: G1/2" thread (option)
10. Sealing ring for G1/2" thread (incl. for option 9)

Scope of delivery

- Density sensor (incl. transport locks)
- Information sheet with download links
- Sealing plug (G1/8")

Product identification

The density sensor is identified by a consecutive 14-digit serial number. This is displayed on the outside of the housing and can also be viewed via the Modbus RTU communication protocol (inspired by Modbus RTU).

Installation, commissioning and un-installation

Fluidic installation of density sensor

⚠ WARNING

Risk of injury due to hazardous process conditions and lack of process tightness

- ▶ Empty the pipeline before installing the density sensor and release the pressure.
- ▶ Ensure that the seals are undamaged and clean.
- ▶ Make sure that the seals are inserted correctly.
- ▶ Do not loosen fluidic connections during operation.
- ▶ The sealing plug is only to be removed and replaced by qualified personnel.
- ▶ Be aware of high temperatures.

1. Remove all traces of the transport packaging.
2. Remove transport locks from fluidic connections.

3. If necessary, screw the adapter for the fluid interface onto the density sensor (tightening torque: 40 Nm).
4. Mount the density sensor on the pipe or tank wall on a threaded socket (tightening torque: 40 Nm). Installation ideally with M8 connection pointing upwards.
5. If necessary, add G1/8" side thread for flow through with compression fitting or hose connection and check for tightness.
6. All sensors are calibrated according to the latest state of the art. A zero point adjustment in the field is therefore not necessary. Zero point adjustment is only recommended in the event of extremely high measuring accuracy requirements or extreme process or operating conditions.

Electrical installation of density sensor

⚠ WARNING

Death or serious injury due to incorrect connection

- ▶ Electrical connection work must only be carried out by suitably trained specialist personnel.
- ▶ Observe national installation regulations.
- ▶ Observe local industrial safety regulations.

⚠ WARNING

No current limiting fuse

- ▶ Ensure overcurrent protection by means of external wiring (fuse: max. 2 A).



⚠ WARNING

Use in potentially explosive areas

The density sensor is not approved for use in potentially explosive areas.

- ▶ Ensure explosion protection when operating in potentially explosive areas.

⚠ WARNING

Risk of injury due to inadequate process tightness

The electronics are surrounded by the medium. If the M8 connection is disconnected, medium can escape.

- ▶ Do not loosen the nut of the M8 connection.
- ▶ Connect the 4-pin M8 plug to the connection. Observe the requirements for the M8 plug, see "Electrical interface" on page 10. The M8 plug is not included in the scope of delivery.
- ▶ Connect the density sensor to the higher-level system. Observe pin assignment, see "Electrical interface" on page 10.

Integration of density sensor into system

The density sensor does not offer its own operating option. The data is read out via serial communication in the RS485 standard. This requires a readout system. The density sensor sends a Modbus RTU communication protocol (inspired by Modbus RTU) to the readout system via the data line.

General settings:

Baud rate	115200 BAUD
Data bits	8
Parity	Keine (0)
Stop bits	1
Modbus Address	1
FlowControl	None (0)
Transmission type	Modbus RTU (inspired by Modbus RTU)
Temperature unit	°C
Pressure unit	Bar
Density unit	kg/m ³
Temperature damping	0 [s]
Pressure damping	0 [s]
Density damping	0 [s]
Selected mixture	0
Selected carrier gas	Gas1
Reference temperature unit	°C
Reference pressure unit	Bar
Concentration min	0 [%]

Concentration max 100 [%]

The following Modbus RTU functions are supported:

Code	Name	Description
0x01	Read Coil	Master reads one or more coil from the device.
0x05	Write Coil	Master writes one or more coil from the device.
0x03	Read Input Registers	Master reads one or more modbus registers from the device.
0x06	Write Input Registers	Master writes one or more modbus registers from the device.

Modbus RTU register information with read/write access:

Name	Address	Data type	Selection/ Input
Baud rate	4912	UINT8	0: 1200
			1: 2400
			2: 4800
			3: 9600
			4: 19200
			5: 38400
			6: 57600
7: 115200			



Parity	4914	UINT8	0: None 1: Even 2: Odd
Name	Adresse	Datentyp	Auswahl/ Eingabe
Stop bits	4916	UINT8	0: 1 Bit 1: 2 Bits
Modbus address	4910	UINT8	1 - 247
Access code	200	UINT16	
Device tag	112	STRING14	
Temperature unit	2109	UINT8	0: °C 1: K 2: °F 3: °R
Pressure unit	2130	UINT8	0: Bar 1: psi 2: Pa
Density unit	2107	UINT8	0: g/cm ³ 1: Reserved 2: kg/dm ³ 3: kg/l 4: kg/m ³
Temperature damping	5127	FLOAT32	0 - 30 [s]
Pressure damping	5506	FLOAT32	0 - 30 [s]
Density damping	5508	FLOAT32	0 - 30 [s]

Selected mixture	210	UINT8	0-14: See «Selected mixture matrix» 15-19: Cust. mix
-------------------------	-----	-------	--

NOTICE

Pure gas measurement

The configuration of the sensor requires the selection of a gas mixture. This makes it possible to use the sensor to measure the concentration with the greatest possible accuracy. A pure gas is a gas mixture that consists 100% of one gas. Therefore, for pure gas measurement, a gas mixture should be selected in the configuration of the sensor that contains the pure gas to be analyzed. Example:

- ▶ Pure gas: Argon (Ar)
- ▶ Possible gas mixtures to be selected:
Ar / H₂, Ar / He, N₂ / Ar, Air / Ar, O₂ / Ar

To optimize the density measurement for a gas or gas mixture that is not included in the standard configuration of the sensor, contact the manufacturer.

	Gas2						
Gas1	H ₂	He	N ₂	Air	O ₂	Ar	CO ₂
H ₂							
He							
N ₂	0	4				9	12
Air	1	5				10	13
O ₂		6				11	14
Ar	2	7					
CO ₂	3	8					

Selected mixture matrix

Selected carrier gas	211	UINT8	0: Gas1 1: Gas2
Reference temperature unit	218	UNIT8	0: °C 1: K 2: °F 3: °R
Reference pressure unit	226	UNIT8	0: Bar 1: psi 2: Pa
Reference temperature	220	FLOAT32	
Reference pressure	222	FLOAT32	
Concentration adjust	224	FLOAT32	0-100 [%]
Concentration min	7000	FLOAT32	[%]
Concentration max	7002	FLOAT32	[%]

NOTICE

User-defined gas mixture:

In addition to the preset gas mixtures for concentration measurement, the sensor can be configured for additional gas mixtures. For this purpose, please contact the manufacturer.

There is a distinction between pure gas adjustment and concentration adjustment.



Selection of pure gas adjustment

1. Ensure that the pure gas in the sensor is free of contamination.
2. Ensure that the carrier gas matches the pure gas in the sensor.
 - a. In the Selected Carrier Gas tab (MB: 211), you can select Gas 1 or Gas 2.
 - b. Gas 1 is the first gas, while Gas 2 is the second gas in the selected gas mixture in the Selected Mixture tab (MB: 210).
3. Ensure stable temperature and pressure conditions in the sensor.
4. Set the Clean Gas Adjustment Coil (MB: 206) to TRUE.
5. Wait until the adjustment is complete.
 - a. When completed, the Clean Gas Adjustment Coil (MB: 206) is reset automatically to FALSE. In addition, the Adjustment Failure Coil (MB: 13) is set to FALSE.
 - b. In case of an error, Adjustment Failure Coil is set to TRUE. The Adjustment Error tab (MB: 208) then provides information about a possible source of error. The sensor repeats the adjustment automatically until it has been carried out successfully. To stop the process, set the Reset Ad-

justment Coil (MB: 207) to TRUE. This resets earlier adjustments.

Selection of concentration adjustment:

1. Ensure that the desired gas mixture is set in the Selected Mixture tab (MB: 210) and the gas mixture is in the sensor.
2. Ensure stable temperature, pressure and concentration conditions in the sensor.
3. Enter the desired target concentration in the Concentration Adjustment tab (MB: 224): Specified in % of the diluted gas in the carrier gas.
4. Wait until the adjustment is complete.
 - a. When completed, the Concentration Adjustment tab (MB: 224) is reset automatically to NAN. In addition, the Adjustment Failure Coil (MB: 13) is set to FALSE.
 - b. In case of error, the Adjustment Failure Coil (MB: 13) is set to TRUE. The Adjustment Error tab (MB: 208) then provides information about a possible source of error. The sensor repeats the adjustment automatically until it has been carried out successfully. To stop the process, set the Reset Adjustment Coil (MB: 207) to TRUE. This resets earlier adjustments.

Resetting the adjustment: (pure gas & concentration adjustment)

1. Reset Adjustment Coil (MB: 207) to TRUE. This resets the adjustment.
2. The Reset Adjustment Coil is reset automatically to FALSE.

Modbus RTU register information with read access:

Name	Address	Data type	Selection/ Input
Memory version	100	UINT8	
Serial number	101	STRING14	
Software version	108	UINT16	
Software build	109	UINT16	
Starter counter	110	UNT16	
Access level	111	UINT8	
Device identity	1	UINT16	
Temperature	9513	FLOAT32	
Pressure	2017	FLOAT32	
Density	2013	FLOAT32	
Reference density	2015	FLOAT32	
Concentration	2598	FLOAT32	



Adjustment error	208	UINT8	0: No error 1: Calibration in process 2: Pressure unstable 3: Temperature unstable 4: Density unstable 5: Offset to large 6: Offset NAN
-------------------------	-----	-------	---

NOTICE**Reference density**

The gas density at reference pressure and reference temperature is referred to as reference density. The reference pressure and reference temperature can be entered by the user (MB tabs 218, 220, 222, 226). Based on the entered reference pressure, the entered reference temperature and measured gas density, the reference density (MB: 2015) is calculated and output.

Modbus RTU coil read/write

Name	Address	Data type	Selection/ Input
Restart Device	202	BOOLEAN	
Enable Modbus Termination	205	BOOLEAN	
Clean gas adjustment	206	BOOLEAN	
Reset adjustment	207	BOOLEAN	

Modbus RTU coil read

Name	Address	Data type	Selection/ Input
Sensor failure	10	BOOLEAN	
Memory error	11	BOOLEAN	
Density out of range	12	BOOLEAN	
Concentration out of range	18	BOOLEAN	
Adjustment failure	13	BOOLEAN	
Temperature out of range	14	BOOLEAN	
Pressure out of range	15	BOOLEAN	
Oscillator failure	16	BOOLEAN	
Pressure Sensor failure	17	BOOLEAN	

Switching on the density sensor

- ▶ Switch on the power supply. After switching on the power supply, the density sensor starts automatically after a short start-up time (<1 second).

Removing the density sensor**⚠ WARNING****Danger to personnel and the environment due to hazardous measuring media**

- ▶ Ensure that no media hazardous to health or the environment can escape when the fluid connection is

released.

1. Disconnect the electrical plug connection from the density sensor.
2. Disconnect the fluidic connection.

Cleaning and repair**Cleaning the housing****NOTICE****The housing and the sensor may be damaged by cleaning agents**

- ▶ Do not use high-pressure gases or liquids.
 - ▶ Only use permissible cleaning agents.
 - ▶ Only carry out cleaning at room temperature.
 - ▶ Make sure that no cleaning agent penetrates into the sensor compartment.
-
- ▶ Clean the housing with permissible cleaning agent. Permissible cleaning agents
 - Mild soap solutions
 - Isopropyl alcohol

Cleaning the filter

To prevent blockages, regularly check the filter installed in the unit for dirt and clean or replace it depending on the degree of contamination. For detailed information on the filter, see "Integrated filter" on page 11.



1. Remove circlip with circlip pliers.
2. Remove filter and spring washer.
3. Replace the spring washer.
4. Insert new filter.
5. Replace the circlip.
6. Replace sealing ring if necessary.

Disposal

Disposing of the density sensor

⚠ WARNING

Danger to personnel and the environment due to hazardous measuring media

- ▶ Ensure that the density sensor and all cavities are free of residues of measuring media that are hazardous to health or the environment.
-
- ▶ Recycle density sensor components. Observe the applicable national regulations.

Product specification

General

Measured variable	<ul style="list-style-type: none"> ▪ Density in kg/m³ ▪ Temperature in °C ▪ Pressure in bar absolute <p>Derived measured variables (customer-specific configuration):</p> <ul style="list-style-type: none"> ▪ Concentration of binary gas mixtures as ideal volume fractions (mole fractions) in % ▪ Standard density ▪ Average molar mass ▪ Customer-specific measured variables
--------------------------	--

Permissible media	<p>⚠ WARNING</p> <p>Danger to life if operated with flammable media.</p> <p>The density sensor is not approved for use in hazardous potentially explosive areas.</p> <ul style="list-style-type: none"> ▶ Do not use for flammable gases or gas mixtures. ▶ Do not use for hydrocarbon gases.
--------------------------	---

Permissible media

(continuance)

NOTICE

Damage to the density sensor.

- ▶ Only use permissible gases or their mixtures with a low moisture concentration (<0.1%).

- Hydrogen (H₂)
- Helium (He)
- Nitrogen (N₂)
- Oxygen (O₂)
- Carbon dioxide (CO₂)
- Argon (Ar)

Media that deviate from the fluids listed above can be used after individual clarification where applicable. These include neon (Ne) and krypton (Kr), for example.

For permissible mixtures, see Modbus register information "Selected mixtures matrix".

Measurement performance

Max. measurement error	<ul style="list-style-type: none"> ▪ Density: <0,1 kg/m³ ▪ Temperature: <0.8 °C ▪ Pressure: <0.04 bar ▪ With field adjustment Density <0.05 kg/m³
Repeatability	<ul style="list-style-type: none"> ▪ Density: <0.015 kg/m³ ▪ Temperature: <0.06 °C ▪ Pressure: <0.005 bar
Measuring rate	10 Hz



Range of application

Density measurement range	0.2...19 kg/m ³
Pressure range	Max. measuring range: 0...10 bar (absolute) NOTICE Use gas mixtures with argon (Ar) only up to a maximum of 9 bar (abs). Bursting pressure: 30 bar
Response time	0,1...120 ms (depends on installation)
Theoretical pore size	50 µm
Vibrations	Under clarification
Inlet and outlet runs	Inlet and outlet runs do not affect the measuring accuracy.

Temperature conditions

Permitted medium temperature	-20...+60 °C
Permitted ambient temperature	-20...+60 °C
Permitted storage temperature	-20...+60 °C

Ambient conditions

Climate class	Not yet defined
Electromagnetic compatibility	EMV 2014/30/EU (EN 61326-1)
Vibration and shock resistance	Not yet defined
Degree of protection (installed condition)	IP67 (IEC 60529)

Dimensions

Dimensions	63 x 27 x 33.5 mm ³ (with M8 plug)
Weight	<150 g

Fluidic interface

Fluidic interface	<ul style="list-style-type: none"> ▪ M22×1.5 thread ▪ Adapter G½" thread (order option)
--------------------------	---

Electrical interface

Connection	M8 connection, 4-pin, according to IEC 61076-2-104
Communication	<ul style="list-style-type: none"> ▪ On the hardware standard RS485. ▪ Modbus RTU communication protocol (inspired by Modbus RTU), see "Modbus RTU register information" on page 6

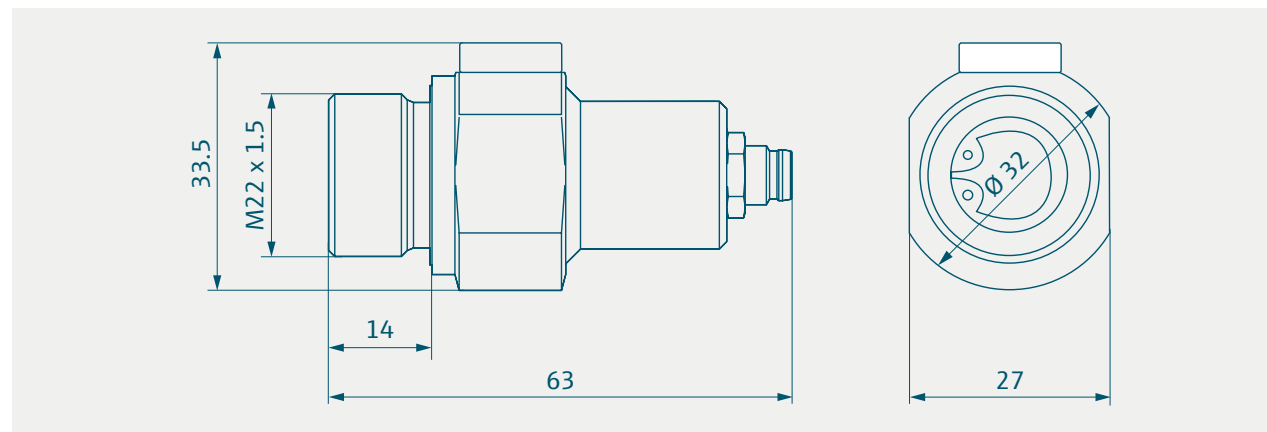

Design, dimensions in mm

Product specification

Materials

Housing	<ul style="list-style-type: none"> ▪ Stainless steel: 1.4404 (316L)
Medium wetted material	<ul style="list-style-type: none"> ▪ Stainless steel: 1.4404 (316L) ▪ Electronic board



Power supply	<p>DC 4.5...12 V (max. 200 mW)</p> <p>Connection cable and plug are not included in the scope of delivery. Requirements for connection cable and plug:</p> <ul style="list-style-type: none"> Power supply unit with safety extra-low voltage (SELV) or protective extra-low voltage (PELV). M8 plug, 4-pin Max. permissible cable length: 30 m Ensure overcurrent protection by means of external wiring (fuse: max. 2 A). Cable recommendation: Lumberg Automation M8 Standard Sensor / Actuator Connectors RKMWW 4-07
---------------------	---

RS485 interface	<ul style="list-style-type: none"> According to standard EIA/TIA-485-A Maximum permissible voltage: <ul style="list-style-type: none"> A and B: -11 V...+15 V (A-B) or (B-A) with active termination: 6 V Switchable 120 Ω termination: deactivated by default (Unit Load: 1/8)
------------------------	---

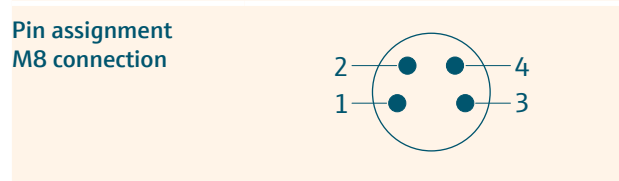

Pin Assignment		
1	V+	Supply voltage
2	A	RS485 Modbus RTU
3	GND	Signal ground
4	B	RS485 Modbus RTU

Integrated filter

Material	Sinter bronze
Theoretical pore size	50 µm

Certificates and approvals

CE mark	The density sensor meets the legal requirements of the EC directives. TrueDyne Sensors AG confirms that the density sensor has been successfully tested by applying the CE mark.
RoHS	All installed components meet the requirements of the RoHS III directive.
Electromagnetic compatibility	according to IEC 61326-1

Accessories and spare parts

Adapter G½" thread	Adapter G½" thread for the fluidic interface.
Sealing ring	Sealing ring for replacing a damaged sealing ring.

Filter	Set consisting of filter, spring washer and circlip for replacing a dirty filter.
Electronic adapter	USB-RS485 incl. M8 plug

