



Product info sheet L Series digital

Humidity/-temperature sensors for digital data transfer RS485 / MODBUS-RTU or RS232 for use in heating, ventilation and air conditioning

- **Two designs**
 - duct version (LK)
 - wall mounting (LW)
- **Different physical outputs**
 - humidity and temperature and all hx values ¹⁾
- **Output signals**
 - RS232 with ASCII protocol
 - RS485 with Modbus RTU protocol
- **Special versions**
 - sealing for increased requirements, e.g. condensation sealing against vibrations
- **Filter**
 - protective basket ZE07 (IP 00)
 - filter with membrane ZE08 (IP30)
 - PTFE sintered filter ZE05 (IP65)

Technical data

Humidity

Sensing element	calibrated sensor chip calHT		
Output range	0...100 %rh		
Accuracy	30...80 %rh	at 10...40°C	±3 %rh
	< 30 %rh or > 80 %rh	at 10...40°C	±5 %rh
Influence of temperature	< 10°C or > 40°C typ. ±0.06 %rh/K		

Temperatur

Sensing element	calibrated sensor chip calHT		
Output ranges	-40...+85°C		
Accuracy	at 10...40°C		±0.8 K
	<10°C and >40°C		see diagramm

Electrical data

Power supply, external	6...30 VDC
Max. transfer distance RS232/RS485	15m/1000 m
Consumption of electronics	< 1,0 mA

Directive about electromagnetic compatibility 2014/30/EU
 DIN EN 61326-1 issue 07/13
 DIN EN 61326-2-3 issue 07/13

1) The accuracy of the calculated values depends on both the operating point in accordance with the hx diagram and on the primary values measured. The hx processor operates in the range -30°C < T < +70°C, 5% rh < F < 95% rh. Values outside this range are not calculated, the last valid value is displayed. Normal atmospheric pressure of 1013.25 mbar is used when calculating the hx values.

General data

Measuring medium	air, pressureless, non-aggressive, non-condensing
Min. air speed	0.5 m/s
Operating temperature	-40...+80°C
Storage temperature	-40...+85°C
Degree of protection of measuring head	
with protective basket ZE07	IP00
with membrane filter ZE08	IP30
with PTFE sintered filter ZE05	IP65
Degree of protection housing	IP65
Material of housing	PC (light grey / white)

Temperature accuracy of the sensors

Working range of humidity and temperature

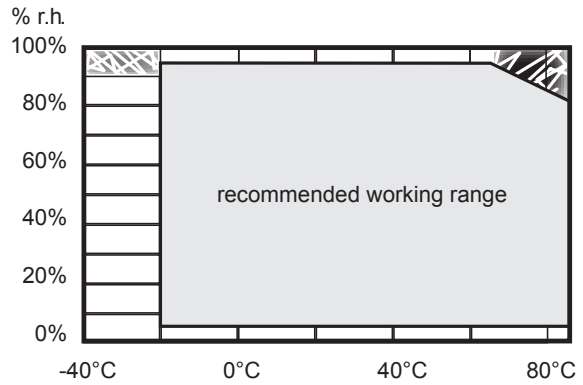
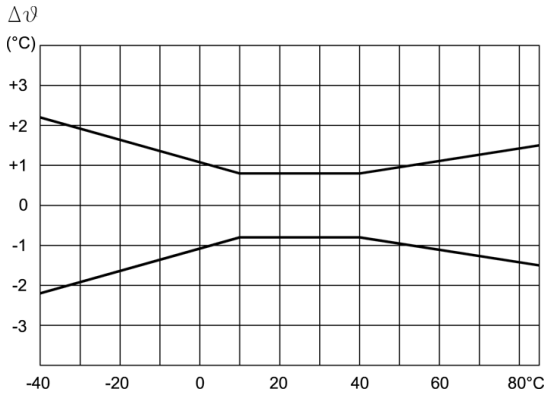

Accessories

Designation	Order reference	Info sheet	Description
Sub-D data line RS232	AWKR.02-00-xx.x	-	Sub-D data line up to max. 15 m for direct connection to serial PC interface; (e.g. 15m: AWKR.02-00-15.0) <i>Note: jack of data line IP30 / -10...50°C !</i>
USB adapter RS232->USB	USB adapter	-	USB adapter for Sub-D-data line <i>To connect up the Sub-D-data line to a USB interface on the PC or Laptop</i>
Setup cable UART -> USB	BKKM.02.AK-01.8	-	Connecting cable sensor --> PC, suitable for all sensors of the L Series digital, to configurate / change the Modbus parameters
ZE36	as designation	F5.2	adapter required for sensor tubes Ø 12mm for humidity standard ZE 31/1 and wall console 20.009
ZE 31/1-12 ZE 31/1-33 ZE 31/1-75 ZE 31/1-84 ZE 31/1-97	as designation	F5.2	humidity standard to check the accuracy of the sensors 12 %rh at 25°C humidity standard to check the accuracy of the sensors 33 %rh at 25°C humidity standard to check the accuracy of the sensors 75 %rh at 25°C humidity standard to check the accuracy of the sensors 84 %rh at 25°C humidity standard to check the accuracy of the sensors 97 %rh at 25°C
ZE33	as designation	F5.2	adapter for humidity standard ZE 31/1
Flange	20.045		fixing flange for sensor tubes Ø 12mm with rubber sealing

Connection diagram RS232

and

RS485

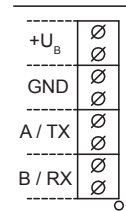
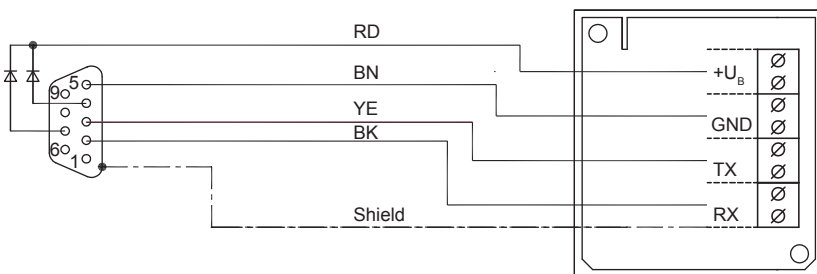

LW(K)KR... with data line AWKR.02.00-xx.x

LW(K)KM...

Product Key
L Series digital

The 16 character alphanumeric order number for the desired type is composed of the order code listed below.

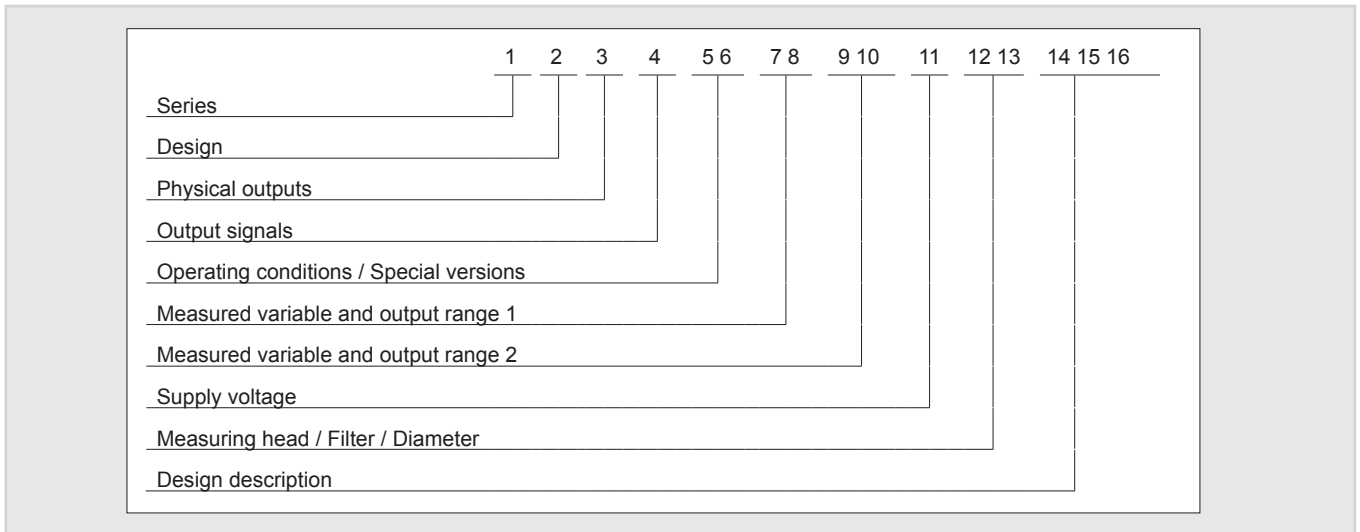

	Technical Data	Options	Order Code
1	Series	L Series	L
2	Design	Duct version	K
		Wall mounting	W
3	Physical outputs	Humidity and Temperature, dew point temperature (°C), enthalpy (kJ/kg), mixing ratio (g/kg), absolute humidity (g/m³) and wet-bulb temperature (°C)	K
4	Output signals	RS232 ASCII protocol	R
		RS485 MODBUS RTU protocol	M
5 6	Operation conditions / special versions	Standard	00
		Sealing against vibrations (optional)	0V
		Sealing for increased requirements (e.g. condensation, optional)	0S
7 8	output range 1	relative humidity and humidity dependant hx values	F1
9 10	output range 2	-40...85 °C	48
11	Supply voltage	6...30 V DC	6
12 13	Measuring head / filter / diameter	ZE05: PTFE sintered filter, Ø 12 mm	05
		ZE07: protective cage, plastic, open, Ø 12 mm	07
		ZE08: protective cage, plastic, with membrane, Ø 12 mm	08
14 15 16	Description of design	Duct sensor, sensor tube length 220 mm (standard)	00 G
		Wall mounting, sensor tube length 50 mm (standard)	00 1

Dimensional drawing series LK

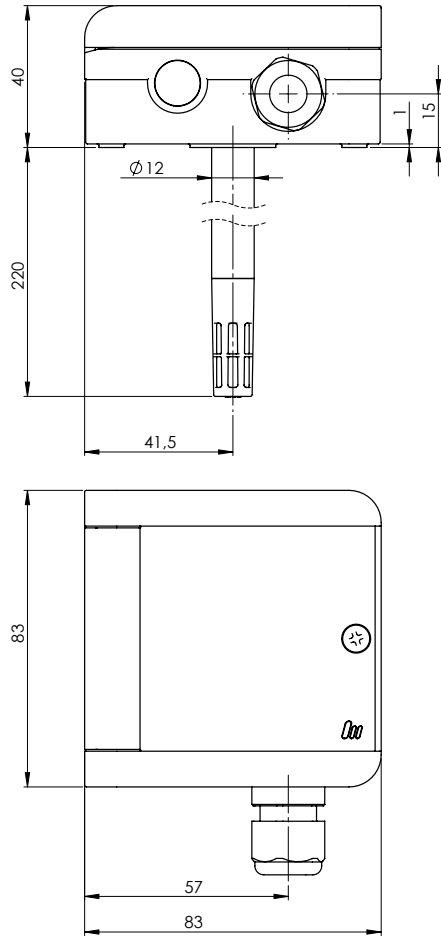

Dimensional drawing series LW

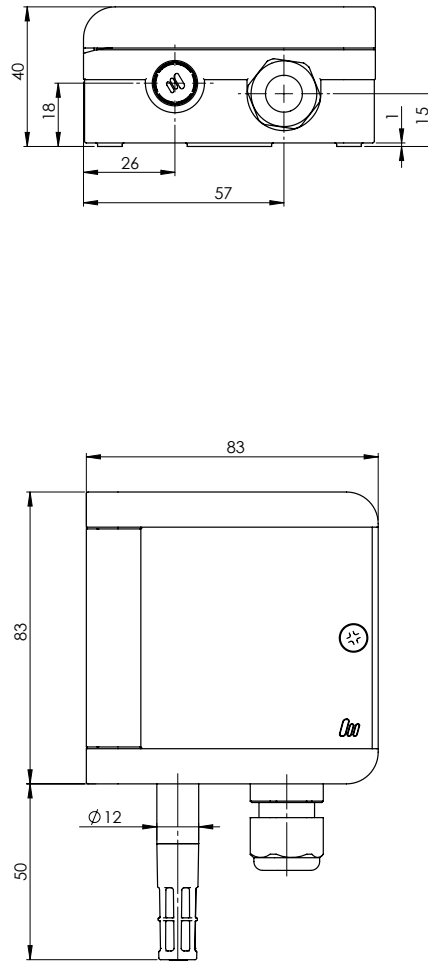

Ordering Example

	L	K	K	M	0V	F1	48	6	05	00G
Series:	L Series									
Design:	Duct version									
Physical outputs:	active outputs									
Output signals:	MODBUS RTU									
Operation conditions / special versions:	Sealing against vibrations									
Measured variable and output range 1:										
Measured variable and output range 2:										
Supply voltage:	6...30 V DC									
Measuring head / Filter / Diameter:	PTFE sintered filter ZE05 / 12 mm									
Description of design	Duct version, sensor tube length = 220 mm									

Mounting and user information

Position	<p>Install the sensor at a place where characteristic levels of humidity occur. The sensor tube resp. measuring head or measuring chamber should be exposed to the flow of air. Avoid installation next to heaters, doors or on outer walls. Avoid places exposed to the sun. Not reaching the given minimum air speed can lead to measurement errors.</p> <p>The sensors for wall mounting (series LW) can be mounted on a patress or directly on the wall. It is important that the surface is even.</p> <p>When mounting the sensors on a patress, avoid external air getting onto the humidity measuring element of the sensor by sealing it appropriately.</p> <p>The sensor should be mounted in such a way that no water can get into it.</p> <p>To close the housing the screw is tightened until it stops.</p> <p>We recommend that you lay the connection lines in a loop so that any water that may be present can run off.</p>
Fixing flange	<p>For mounting the fixing flange (duct mounting of series LK), a hole pattern is printed on the packaging.</p> <p>To fix the sensor, simply open the opening tab of the flange by finger pressure or with the help of a pair of pliers. The sensor can be fixed in the flange at any position.</p>
Connection	<p>The electrical connection must be carried out by qualified personnel only. The sensors of the L Series contain components, which can be damaged by the effects of electrical fields or by charge equalisation when touched. When mounting the sensor, protective measures must be taken.</p> <p>Lines to and from the sensor must not be installed parallel to strong electromagnetic fields. In the case of a possible overvoltage please install surge protection devices.</p>
Dew formation	<p>Dew formation and splashes do not damage the sensor, although measurement readings are corrupted until all moisture on and around the sensing element has dried up completely.</p>
Contaminated filters	<p>If the PTFE sintered filter ZE05 and the membrane filter ZE08 is contaminated with dust, grease and oils, this can have a negative impact on the dynamic behaviour of the sensor.</p>
Cleaning of filters	<p>If necessary, soiled filters and protective baskets can be screwed off and rinsed carefully. Bear in mind the sensors will not measure accurately until filters are completely dry. Please do not touch the highly sensitive sensing element.</p>
Cleaning of sensor chip	<p>Loose dust can be carefully cleaned off the humidity sensing element using distilled water or by blowing the dust carefully off. Please do not touch the highly sensitive humidity sensing element.</p>
Damaging influences	<p>Depending on their type and concentration, aggressive media containing solvents can cause incorrect readings or cause the sensor to fail.</p> <p>Substances deposited on the sensor element (e.g. fats, oils, resin aerosols, paint aerosols, smoke deposits etc.) are harmful as they eventually form a water-repellent film or deteriorate the dynamic behaviour of the sensor.</p>

RS485 with MODBUS-RTU Protocol

Serial interface

The following parameters are possible for data transfer via the EIA-485 interface on the ModBus sensors made by Mela®:

- Baud rate: 19200 / 9600 / 4800 / 2400 / 1200 / 600
- Data bits: 8
- Parity: N / E / O
- Stop bits: 1 / 2

Modus 19200@8N2 is pre-defined.

Access to Modbus registers

To ensure compatibility with all Modbus masters, all available registers can be read both with function code 03_{hex} (read holding register), as well as with function code 04_{hex}. Registers with additional write permission can be modified with function code 06_{hex} (write holding register). All registers available with Modbus sensors by Mela are listed in table 1.

Register-no.	Data type	Value	Permission
0	FLOAT32	Temperature (°C)	readable
1			
2	UINT16	Alarm code temperature	
3	FLOAT32	Relative humidity (%rH)	
4			
5	UINT16	Alarm code humidity	
6	UINT32	Serial number sensor	
7			
8	UINT32	Serial number sensor	
9			
10	FLOAT32	Dew point temperature (°C)	
11			
12	FLOAT32	Enthalpy (kJ/kg)	
13			
14	FLOAT32	Mixing ratio (g/kg)	
15			
16	FLOAT32	Absolute humidity (g/m³)	
17			
18	FLOAT32	Wet-bulb temperature (°C)	
19			
20	UINT16	Alarm code hx processor	
205	UINT16	Modbus address	read and writeable

Table 1 - Modbus register

Functioning

The measured values for relative humidity, temperature and the corresponding alarm codes are saved in registers 0...5 in a cycle time of 2s. Registers 6(8) and 7(9) contain the sensor's serial number. If an hx value is scanned from registers 10...19, this is recalculated at the time of the scan, based on the current temperature and the relative humidity. The hx processor emits an alarm code if the values for temperature or relative humidity are outside the permissible input range. No calculation is made in this case, and the register displays the last valid value for each variable.

The memory organisation for the temperature and air humidity readings, as well as for the serial number, is Little Endian. This means that the low byte word is in the lower register and the high byte word is in the higher register.

Table 2 lists all the possible alarm register values when measuring temperature (reg. no. 2).

Alarm code	Meaning
0	no alarm, the temperature value is within the limits
3	no sensor element detected

Table 2 - alarm codes temperature

Table 3 lists all the possible alarm register values when measuring humidity (reg. no. 5).

Alarm code	Meaning
0	no alarm, the humidity value is within the limits
3	Wire break or no sensor element detected

Table 3 - alarm codes humidity

Table 4 lists all the possible alarm register values of the hx processor (reg. no. 20).

Alarm code	Meaning
0	no alarm, input values are within the limits
1	max. input value of humidity 95%rh and/or temperature +70°C is exceeded
2	min. input value of humidity 5%rh and/or temperature -30°C is below limit
3	hx processor deactivated

Table 4 - alarm codes hx processor

The Modbus address can be modified at any time via write access to the address register (reg. no. 205). Permissible slave addresses are within the 1...247 range. Using address 0 as a slave address is not permissible. Addresses within the 248...255 range are reserved for special Modbus services and their use as a slave address is not permissible either. Address 1 is pre-defined.

Configuration of Modbus parameters

In standard mode (and in the network if required), the Modbus address for all sensors can be modified by entering an appropriate write command. The write command will still be acknowledged using the old address. The sensor can then be accessed immediately via the new address.

Further configuration of Modbus parameters, such as address, baud rate, parity and stop bits is only possible with the suitable setup cable BKKM.02.AK-01.8 (see accessories on page 2). These settings are then made from a PC via the **ModSens-Setup** software available for download. For this, the sensors must not be in the network.

The above mentioned software is available on our Homepage as a free download (<http://melasensor.de/download/>).

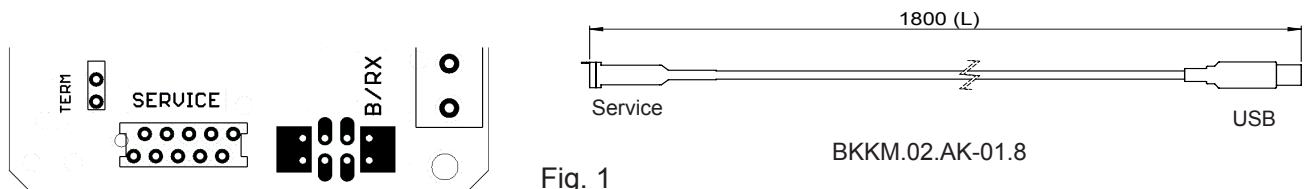

Fig. 1

BKKM.02.AK-01.8

The **ModSens Setup** software and the documentation are available on our Homepage as a free download (<http://melasensor.de/download/>).

Operation

To connect directly to a PC, all you need is an integrated RS485 interface or an external adaptor. Mains power can also often be supplied in this way. A software program such as Modbus Poll will then assume the role of the master.

Further measures must be taken for more challenging applications in the network, for long distances and/or in environments with electromagnetic interference. The bus must be designed in a daisy chain structure without spurs. For this reason, any cables connected to the sensors have a double data line pair – one incoming and one outgoing. The data line must be designed as a screened and twisted pair. The first and the last bus nodes must be terminated. If DC termination is sufficient, the integrated resistance of 135Ω can be switched between A and B – provided this is available on the relevant model. To do this, switch the jumper in the appliance to the corresponding position or bridge the corresponding pins in the connector. If you have to use transmission line polarisation, we advise against using DC termination. Instead you should use AC termination. The required series connection for the resistor and the capacitor can then be switched between A and B on the second data line pair of the connection cable or on the second terminal pair in the terminal block.

A Mela Modbus sensor according to the RS485 standard represents 1/8 unity load. If the network only contains sensors in this impedance category, 256 bus nodes are theoretically possible instead of 32. However, due to the available address space, in practice the number reduces to 247.

The scanning interval should not exceed 2 seconds across the entire network.

For further information see <http://www.modbus.org/>.

RS232 with ASCII Protocol

Serial interface

The data transfer via the RS232 interface is effected with the following parameters:

- Baud rate: 9600
- Data bits: 8
- Parity: N
- Stop bits: 1

If power is also supplied to the sensor via the interface, the RTS and DTR signals must also be permanently enabled.

ASCII protocol

Approximately every 3 seconds (approx. 5 sec in case of an error), the sensor transmits a character string containing the measured values for relative humidity, temperature and the corresponding alarm codes and serial numbers. A checksum ensures the validity. The output character string has a constant length of 41 characters in the following format:

```
@T;<Sign>;<Temperature>;<Alarmcode>;F;<Humidity>;<Alarmcode>;<Serialnumber>;<Sum>\r\n
```

The individual characters and fields have the following meanings:

„@“	Begins a protocol frame
„T“	Marks the temperature value
„F“	Marks the humidity value
„.“	Separator
„\r“	Carriage Return
„\n“	Line Feed
<Sign>	Temperature plus/minus sign, „+“ or „-“
<Temperature>	5 characters, two integer places, two decimal places from „0“ ... „9“, Comma symbol is „.“
<Alarmcode>	3 characters, „A00“ ... „A04“
<Humidity>	6 characters, three integer places, two decimal places from „0“ ... „9“, comma symbol is „.“
<Serialnumber>	8 characters from „0“ ... „9“
<Sum>	2 characters from „0“ ... „9“ or „A“ ... „F“

Examples:

- 1: @T;+021.37;A00;F;038.92;A00;12345678;38\r\n
- 2: @T;+018.97;A00;F;099.54;A00;00251979;0A\r\n

Table 1 lists all the possible values when measuring temperature

Alarm code	Meaning
A00	No alarm, the temperature value is within the limits
A03	no sensor element detected

Table 2 lists all the possible values when measuring humidity

Alarm code	Meaning
A00	no alarm, the humidity value is within the limits
A03	no sensor element detected

The sum is calculated according to the following algorithm with reference to example 1:

1. Add up the decimal representation of all ASCII characters from “@” to the final “;”
 $64 („@“) + 84 („T“) + 59 („;“) + 43 („+“) + 48 („0“) + 50 („2“) + \dots + 54 („6“)+ 55 („7“)+ 56 („8“) + 59 („;“) = 1991$
2. Divide this sum by 256 to find the remainder
 $1991 \% 256 = 199$
3. Subtract the remainder from 255
 $255 - 199 = 56$
4. Interpret the decimal result as a hexadecimal number
 $56 = 38_{\text{hex}}$
5. Compare the individual hexadecimal numbers with the transmitted ASCII characters of the checksum
 $38_{\text{hex}} \rightarrow „3“ \& „8“ \checkmark$

VisualPMU Freeware for RS232

This simple and very clear visualisation software supports the data output of a sensor via a serial interface on the PC or laptop without an additional power supply.

To use this, it is necessary to install the accessory *Sub-D data line* (refer to accessories and connection diagrams). For USB connections, a *USB adapter* can be supplied (see accessories).

The relative humidity, the dew point and the temperature (°C or °F) can be displayed and can be depicted as a graph. Apart from that, the programme has a simple data logger function. Recorded data can be exported to other programmes. This freeware version can be found on our Homepage as a free download (<http://melasensor.de/download/>).

This information is based on current knowledge and is intended to provide details of our products and their possible applications. It does not, therefore, act as a guarantee of specific properties of the products described or of their suitability for a particular application. It is our experience that the equipment may be used across a broad spectrum of applications under the most varied conditions and loads. We cannot appraise every individual case. Purchasers and/or users are responsible for checking the equipment for suitability for any particular application. Any existing industrial rights of protection must be observed. The quality of our products is guaranteed under our General Conditions of Sale. Data sheet L Series_digital_e. Issue: October 2017. Subject to modifications