

LQX12

12 mm Miniature Diaphragm Isolation Valve



Typical Applications

- Clinical Diagnostics Instrumentation
- Hematology
- Automated Slide Stainers
- DNA/RNA Synthesis
- Environmental Analyzers
- VOC/TOC

Product Specifications

Physical Properties

Valve Type:	Diaphragm Rocker Isolation Valve
Valve Configuration:	3-Way Universal 2-Way Normally Closed
Media:	Liquids
Operating Environment:	32 to 122°F (0 to 50°C)
Storage Temperature:	-40 to 158°F (-40 to 70°C)
Dimensions:	Width: 0.47" (12 mm) Height: 1.57" (39.88 mm) Length: 1.16" (29.46 mm)
Weight:	Face seal: 0.86 oz (24.7 g) with 1/4-28 sub-base 1.1 oz (31.7g)
Porting:	Face seal, 1/4-28 sub-base
Internal Volume (µL):	32 manifold interface 61.5 with sub base manifold

LQX12 is a high-performance 2-way and 3-way universal isolated diaphragm valve. This highly flexible design is 12 mm wide and offers two different elastomer options. LQX12 supports the pressure and flow requirements needed by today's analytical, bio-analytical, and clinical diagnostic OEMs.

Features

- EPDM or FFKM elastomers for particulate tolerance and reliability in a wide range of liquid media
- 100% tested leak rate ensures a tight seal on every valve
- 12 mm width allows for reduced system sizes and efficient packaging
- Designed to be manifold mounted side-to-side on 12 mm centers
- Low internal unswept volume to minimize carryover and cross-contamination
- Secure electrical termination to female connectors with friction-locked latching electrical connection
- Optional 1/4-28 ported sub-base for stand alone operation or testing
- RoHS compliant 

Electrical

Voltage (VDC):	12 and 24 VDC ± 5%	
Power (Watts):	2.0 Max	
	12V	24V
Current (mA):	162	76
Resistance (Ohm):	74.2	316
	(Ω±5% @ 70°F, 21.1°C)	
Connections:	2.54 mm pitch male pins 18" (46 cm) Lead Wire Connector Assembly (Accessory, see ordering info.)	

Wetted Materials

Seals:	EPDM or FFKM
Body:	PEEK (polyetheretherketone)
Manifold:	PEEK (polyetheretherketone)
	See Chemical Compatibility Page Consult factory for other options

Performance Characteristics

Operating Pressure/	
Orifice Diameters:	Vacuum - 40 psi (2.8 bar), EPDM Vacuum - 50 psi (3.4 bar), FFKM 0.040" (1.02 mm)
Proof Pressure:	100 psig (6.9 bar)
Leak Rate:	Bubble Tight
Response Time:	20 ms maximum closed - open
Recommended Filtration:	40 micron
Reliability*:	Life Cycle Rating of 10 million (EPDM [pressure and vacuum] and FFKM [pressure]) Life Cycle Rating of 5 million (FFKM [vacuum]) *Application dependent

LQX12 Miniature Diaphragm Isolation Valve

Typical Flow Curve

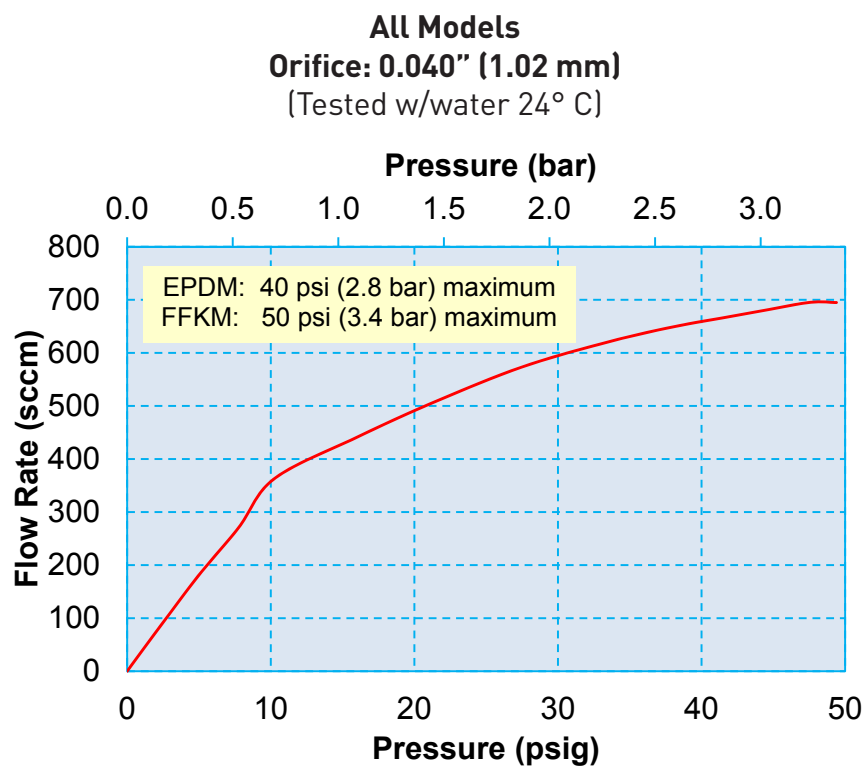

Electrical Interface



Male Pins



Wire Leads*
18" (46 cm)

*Custom lead length available.

Liquid Interface



1/4" - 28 Ports
(Threaded Connector)



Face Seal
(Manifold Mount)

LQX12 Miniature Diaphragm Isolation Valve

Mechanical Integration

Dimensions

LQX 12: 2-Way Cross Section Wetted Material and Dimensions

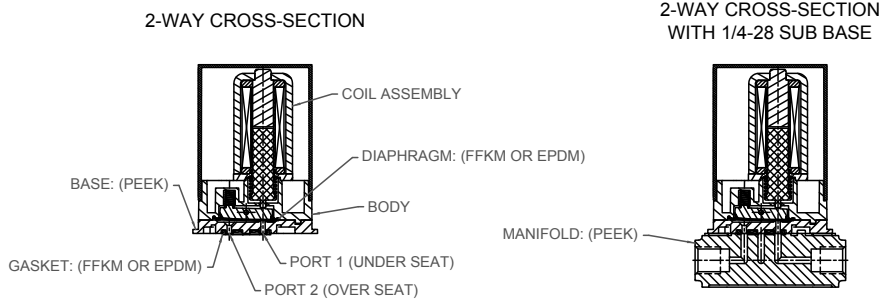

DIMENSIONS: 2-WAY FACE SEAL

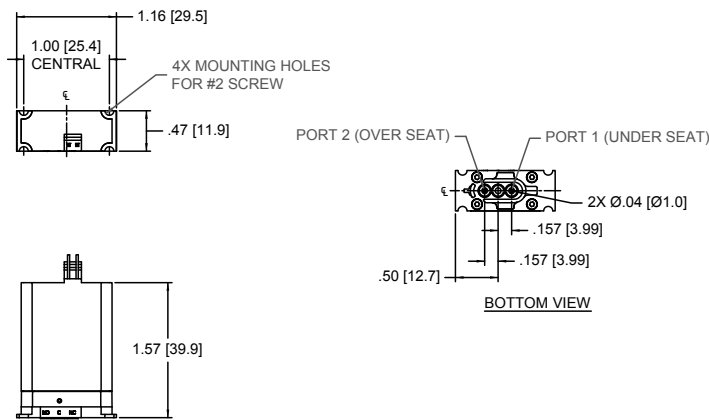

2-WAY MANIFOLD 1/4-28 SUB BASE

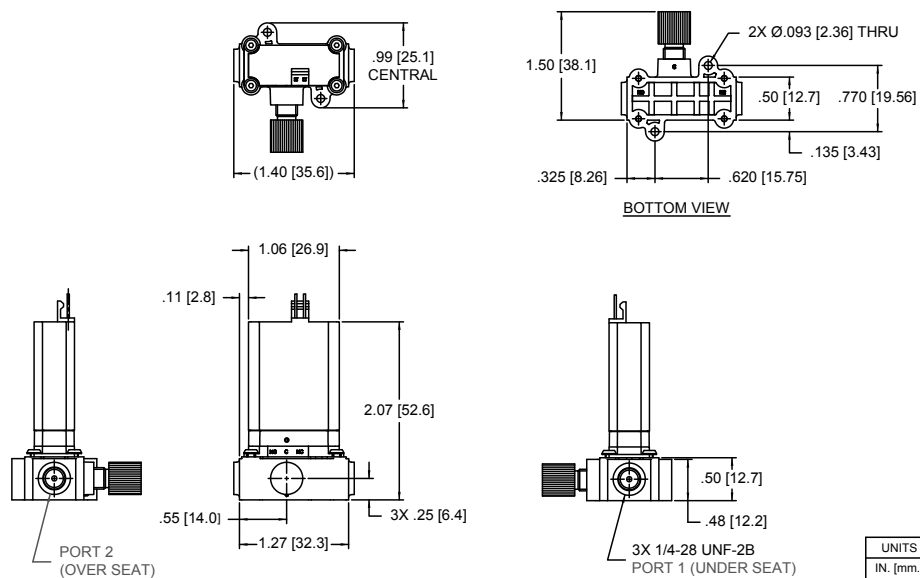

LQX12 Miniature Diaphragm Isolation Valve

Mechanical Integration

Dimensions

LQX 12: 3-Way Cross Section Wetted Material and Dimensions

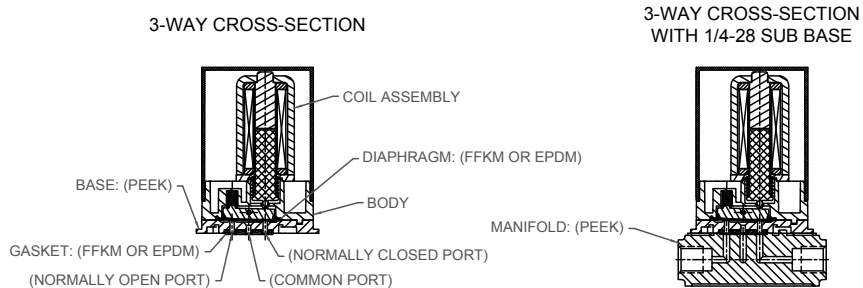

DIMENSIONS: 3-WAY FACE SEAL

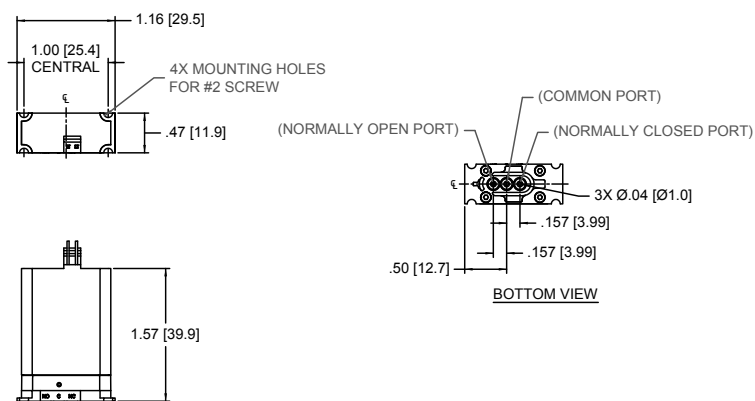

3-WAY MANIFOLD 1/4-28 SUB BASE

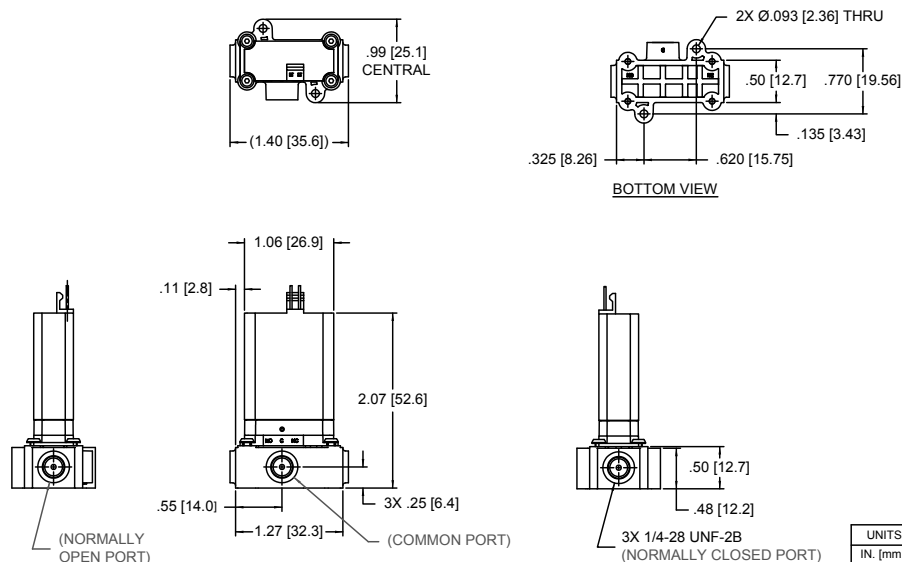

UNITS
IN. [mm.]

LQX12 Miniature Diaphragm Isolation Valve

ANSI Symbols

Pressure

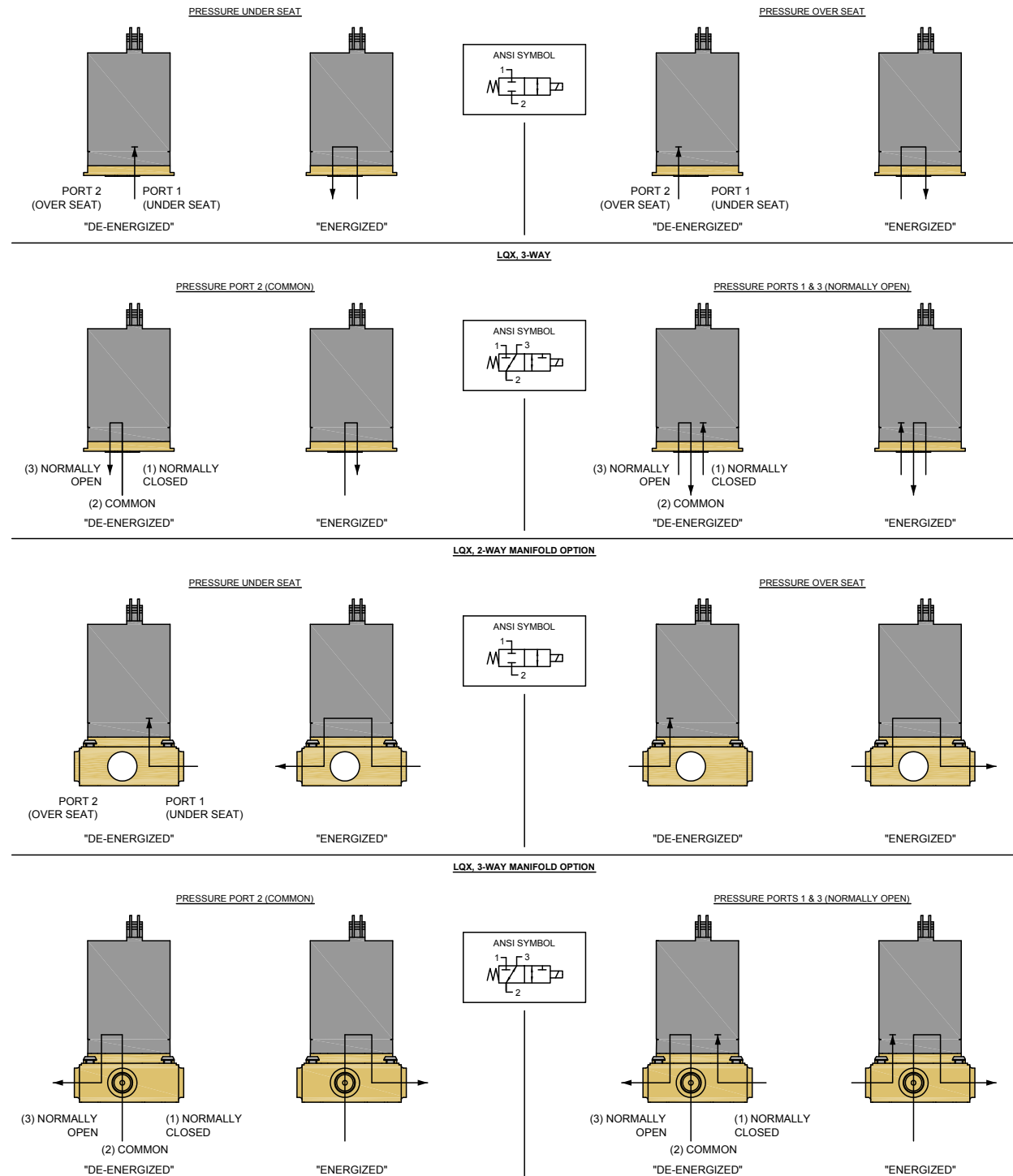

LQX12 Miniature Diaphragm Isolation Valve

ANSI Symbols

Vacuum

LQX ANSI SYMBOLS (VACUUM) LQX, 2-WAY

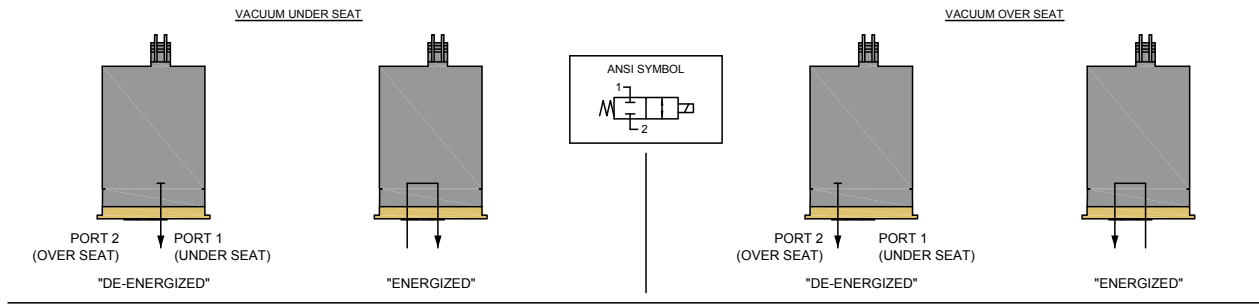

LQX, 3-WAY

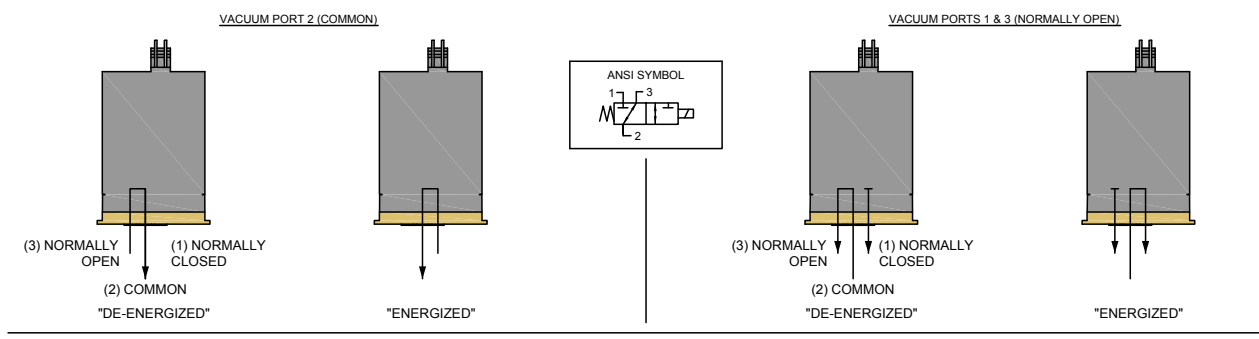

LQX, 2-WAY MANIFOLD OPTION

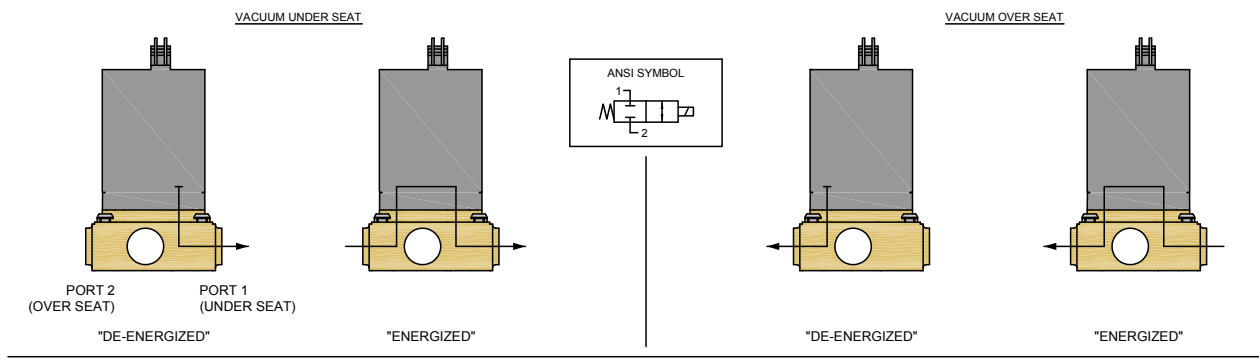

LQX, 3-WAY MANIFOLD OPTION

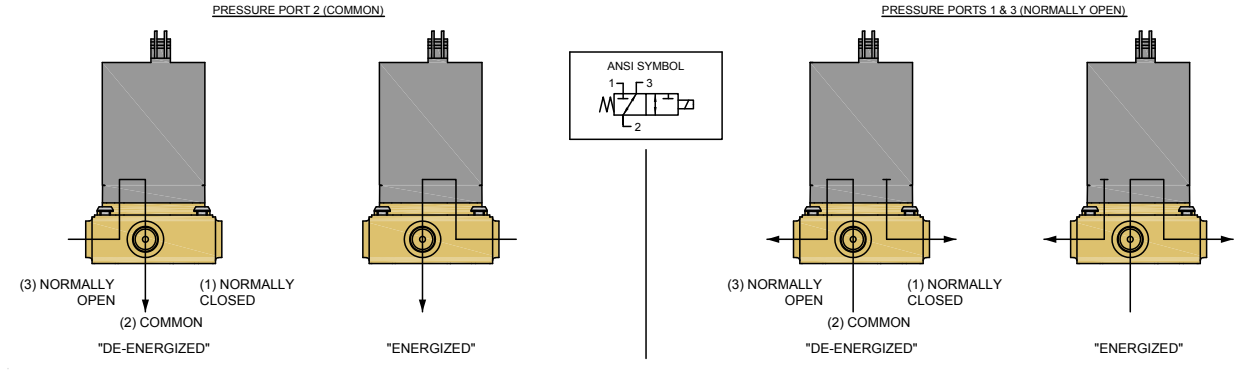

LQX12 Miniature Diaphragm Isolation Valve

Hit and Hold Specifications

Hit and Hold is a method for driving valves that can be used to reduce power consumption and heat generation while maintaining valve performance specifications. The valve is "hit" with the full rated voltage for some time period to open it (T1 in the graph) and then "held" open with substantially reduced voltage until the desired pulse length is reached (T2 in the graph). The following table shows the possible holding voltages and power consumption for our standard 12 and 24 VDC solenoids.

Rated Voltage (VDC)	2-way		3-way	
	Hold Voltage	Hold Power	Hold Voltage	Hold Power
24	8 VDC	0.46 watts	12 VDC	1.04 watts
12	5 VDC	0.44 watts	6 VDC	0.63 watts

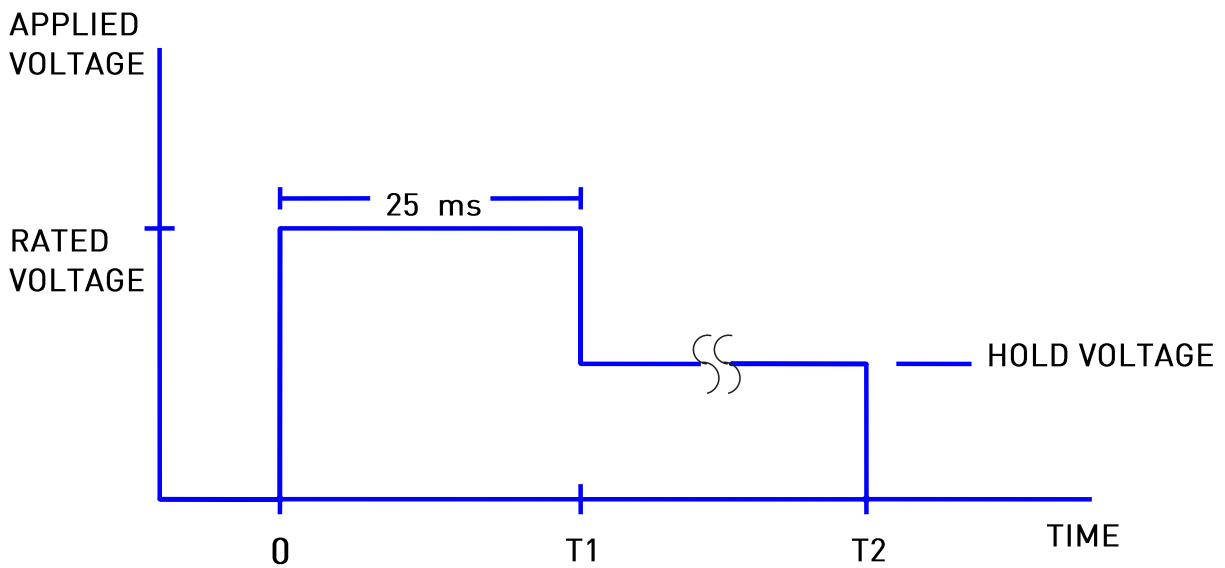

Hold Voltage Graph

LQX12 Miniature Diaphragm Isolation Valve

Chemical Compatibility Chart*

Chemical	Diaphragm Options			Other Wetted Materials
	FFKM	or	EPDM	PEEK
DI Water	1		1	1
Methanol	1		1	1
Isopropanol	1		1	1
Ethanol	1		1	1
Acetonitrile	1		1	1
Tetrahydrofuran	1		4	1
Toluene	1		4	1
Organic Acids - Dilute	1		1	1
Non Organic Acids - Dilute	1		1	1
Bases - Dilute	1		1	1
Saline	1		1	1
Bleach 12%	2		1	1
Sodium Hydroxide 20%	1		1	1

*The above is an Abbreviated Chemical Compatibility Chart. Please consult factory for a complete list.

COMPATIBILITY LEGEND	
1 EXCELLENT	Minimal or no effect
2 GOOD	Possible swelling and/or loss of physical properties
3 DOUBTFUL	Moderate or severe swelling and loss of physical properties
4 NOT RECOMMENDED	Severe effect and should not be considered

LQX12 Miniature Diaphragm Isolation Valve

Typical Flow Diagram

Oligonucleotide Synthesis Application

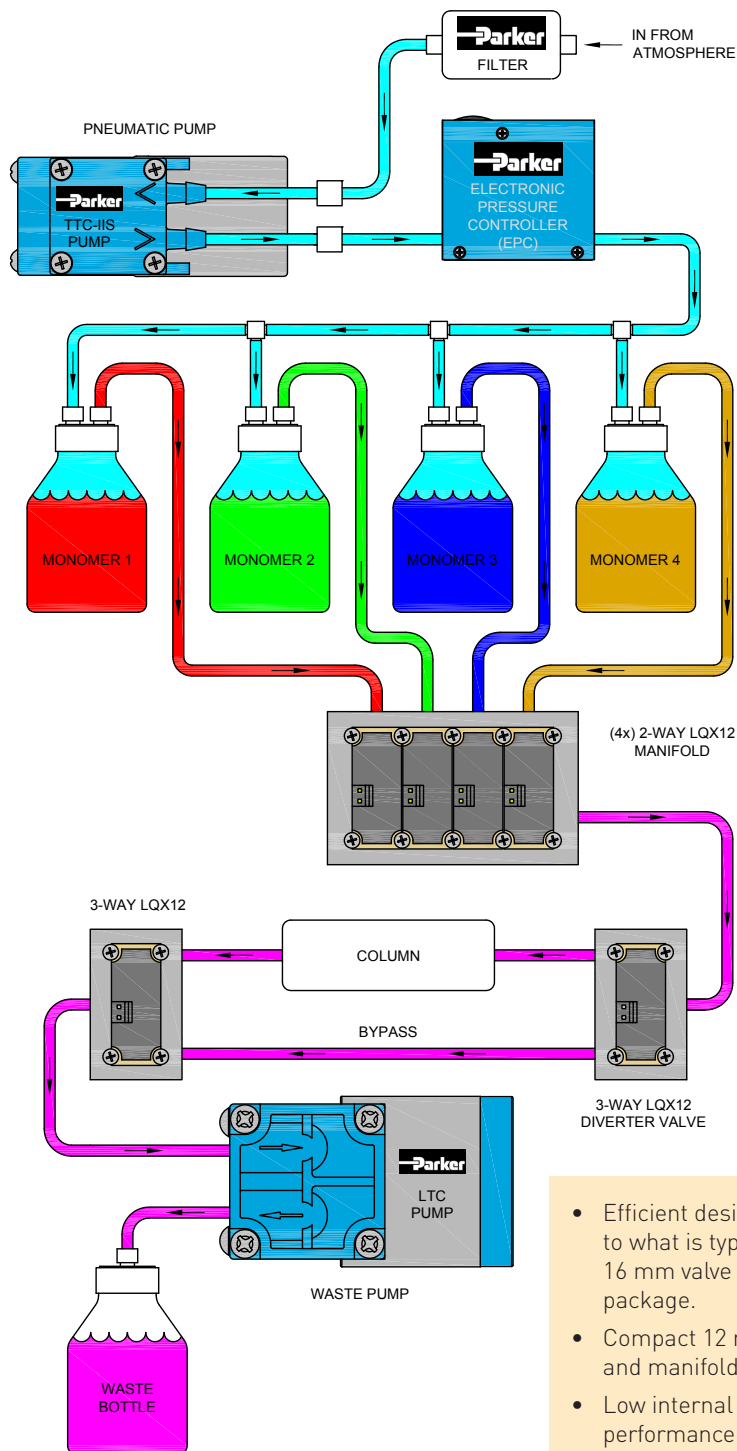

- Efficient design provides flow close to what is typically expected in a 16 mm valve in a 12 mm wide package.
- Compact 12 mm size saves space and manifold costs
- Low internal volume and high performance is ideal for applications requiring low carryover compared to the industry leading 16 mm valve

LQX12 Miniature Diaphragm Isolation Valve

Recommended LQX Valve Mounting

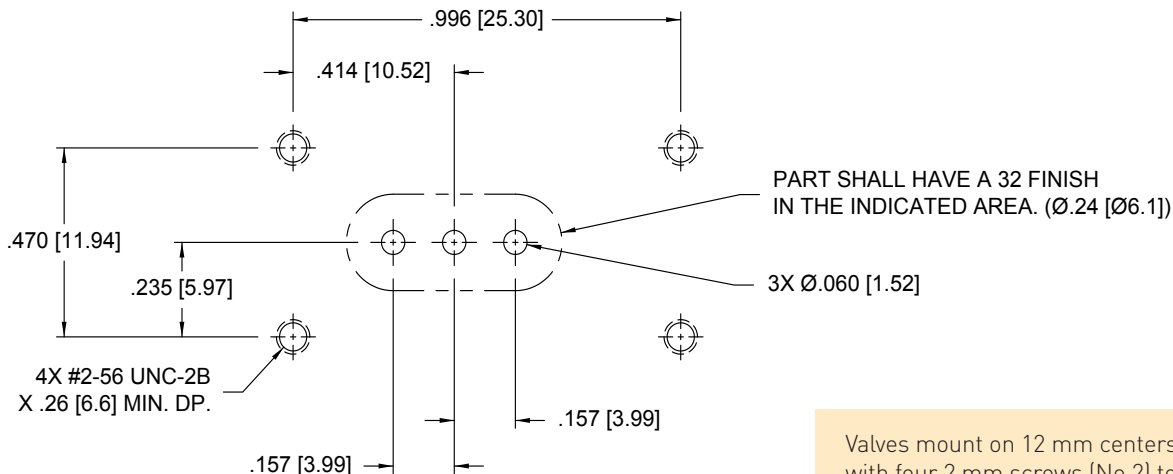

Valves mount on 12 mm centers with four 2 mm screws (No.2) to a maximum torque of 0.11N-m (15 in-oz).

UNITS
IN [MM]

Accessories

LQX12 18" (46 cm) Cable Assembly LQX-0001-290-001

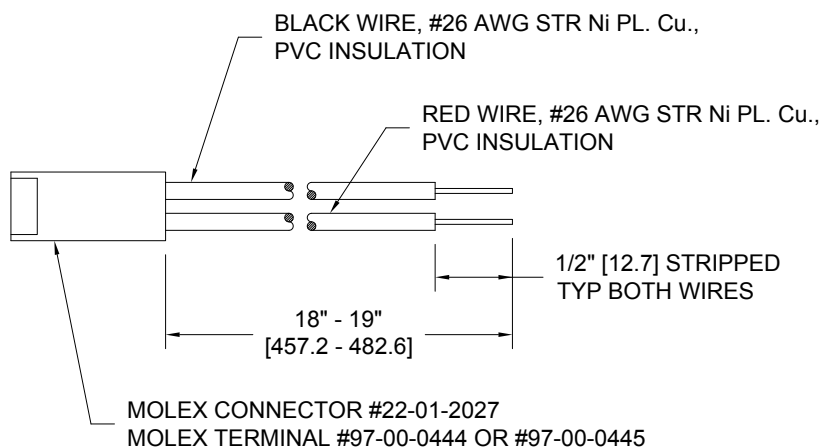

LQX12 Miniature Diaphragm Isolation Valve

Ordering Information

Valve Type	Seal Material	Pressure	Voltage	Electrical Connection	Porting	Part Number
2- Way NC	FFKM	Vac-50psig (3.4 bar)	12V	2.54mm male pins	Manifold Mount	LQX12-2W12FFFS-000
					1/4 - 28	LQX12-2W12FF48-000
				Flying leads	Manifold Mount	LQX12-2W12FFFS-001
				1/4 - 28	LQX12-2W12FF48-001	
			24V	2.54mm male pins	Manifold Mount	LQX12-2W24FFFS-000
					1/4 - 28	LQX12-2W24FF48-000
	Flying leads	Manifold Mount		LQX12-2W24FFFS-001		
			1/4 - 28	LQX12-2W24FF48-001		
	EPDM	Vac-40psig (2.8 bar)	12V	2.54mm male pins	Manifold Mount	LQX12-2W12EPFS-000
					1/4 - 28	LQX12-2W12EP48-000
				Flying leads	Manifold Mount	LQX12-2W12EPFS-001
				1/4 - 28	LQX12-2W12EP48-001	
24V			2.54mm male pins	Manifold Mount	LQX12-2W24EPFS-000	
				1/4 - 28	LQX12-2W24EP48-000	
	Flying leads	Manifold Mount	LQX12-2W24EPFS-001			
		1/4 - 28	LQX12-2W24EP48-001			
3-Way	FFKM	Vac-50psig (3.4 bar)	12V	2.54mm male pins	Manifold Mount	LQX12-3W12FFFS-000
					1/4 - 28	LQX12-3W12FF48-000
				Flying leads	Manifold Mount	LQX12-3W12FFFS-001
				1/4 - 28	LQX12-3W12FF48-001	
			24V	2.54mm male pins	Manifold Mount	LQX12-3W24FFFS-000
					1/4 - 28	LQX12-3W24FF48-000
				Flying leads	Manifold Mount	LQX12-3W24FFFS-001
					1/4 - 28	LQX12-3W24FF48-001
			EPDM	Vac-40psig (2.8 bar)	12V	2.54mm male pins
		1/4 - 28				LQX12-3W12EP48-000
	Flying leads	Manifold Mount				LQX12-3W12EPFS-001
		1/4 - 28			LQX12-3W12EP48-001	
	24V	2.54mm male pins			Manifold Mount	LQX12-3W24EPFS-000
					1/4 - 28	LQX12-3W24EP48-100
		Flying leads			Manifold Mount	LQX12-3W24EPFS-001
					1/4 - 28	LQX12-3W24EP48-101

NOTE: In order to provide the best possible solution for your application, please provide the following requirements when contacting Applications Engineering:

- Media, Inlet & Outlet Pressures
- Minimum Required Flow Rate
- System Supply Voltage
- Media
- Ambient Temperature Range

Please click on the Order On-line button (or go to www.parker.com/precisionfluidics/lqx12) to configure your Liquid X Miniature Diaphragm Isolation Valve. For more detailed information, visit us on the Web, or call 603-595-1500.



LQX12 Miniature Diaphragm Isolation Valve

Ordering Information

Accessories
LQX-0001-290-001: LQX 18" (46 cm) Cable Assembly

NOTE: In order to provide the best possible solution for your application, please provide the following requirements when contacting Applications Engineering:

- Media, Inlet & Outlet Pressures
- Minimum Required Flow Rate
- System Supply Voltage
- Media
- Ambient Temperature Range

Please click on the Order On-line button (or go to www.parker.com/precisionfluidics/lqx12) to configure your Liquid X Miniature Diaphragm Isolation Valve. For more detailed information, visit us on the Web, or call 603-595-1500.

