

Lone Wolf Normally Open Miniature Proportional Valve

Thermally Compensated Proportional Valve



The Lone Wolf miniature proportional valve is a thermally compensated 2-way normally open (NO) proportional valve designed to maintain accurate and repeatable flow over a wide range of media. With the highest performance characteristics of any NO proportional valve available on the market, the Lone Wolf miniature proportional valve is an ideal choice for medical devices and patient monitoring applications that require rapid response along with stable and accurate performance.

Features

- Provides rapid, stable performance to improve system accuracy
- Enhances system control and patient comfort
- Maintains ideal flow across numerous media types and its entire operating temperature range
- Proven performance tested to 100 million life cycles
- RoHS compliant 

Typical Applications

- Blood Pressure Monitoring
- Vitreo Retinal Surgery

Product Specifications

Physical Properties

Valve Type:
2-Way Normally Open
Media:
Air, argon, helium, hydrogen, methane, nitrogen, oxygen, & others
Operating Environment:
32 to 131°F (0 to 55°C)
Storage Temperature:
-40 to 158°F (-40 to 70°C)
Length:
1.79 in (45.3 mm)
Width:
0.63 in (16.5 mm)
Height:
0.67 in (17.0 mm)
Porting:
Barbs; manifold mount (with available screens)
Weight:
2.2 oz (62.9 g)

Physical Properties

Internal Volume:
0.031 in ³ (0.508 cm ³)
Filtration: (Suggested and Available)
40 micron
Flow Direction:
Inlet Port Port 1
Outlet Port Port 2

Electrical

Power:
2.0 Watts maximum
Voltage:
See Table 2
Electrical Termination:
18 in Wire Leads, PC Mount

Wetted Materials

Body:
360 HO ₂ Brass
Stem Base:
430 FR Stainless Steel and Brass 360 HT
All Others:
FKM; 430 FR Stainless Steel; 300 Series Stainless Steel

Performance Characteristics

Leak Rate:
The leakage shall not exceed the following values: Internal 0.2 SCCM of He with a differential pressure of 1 psid, 5 psid and 25 psid External 0.016 SCCM of He at 25 psig
Pressure:
0 to 10 psi (0.69 bar) 0 to 20 psi (1.37 bar) 0 to 25 psi (1.72 bar) See Table 1
Vacuum:
0-20 in Hg (0-508 mm Hg)
Orifice Sizes:
0.024 in (0.61 mm) 0.030 in (0.76 mm) 0.036 in (0.91 mm)
Hysteresis:
7% of full scale current (Typical) 15% of full scale current (Max)

VSO is a registered trademark of Parker Hannifin Corporation.



Lone Wolf Thermally Compensated Proportional Valve

Typical Flow Curve

All Models
Typical Air Flow with 13.5 VDC Coil @ 5 psid (0.34 bar)

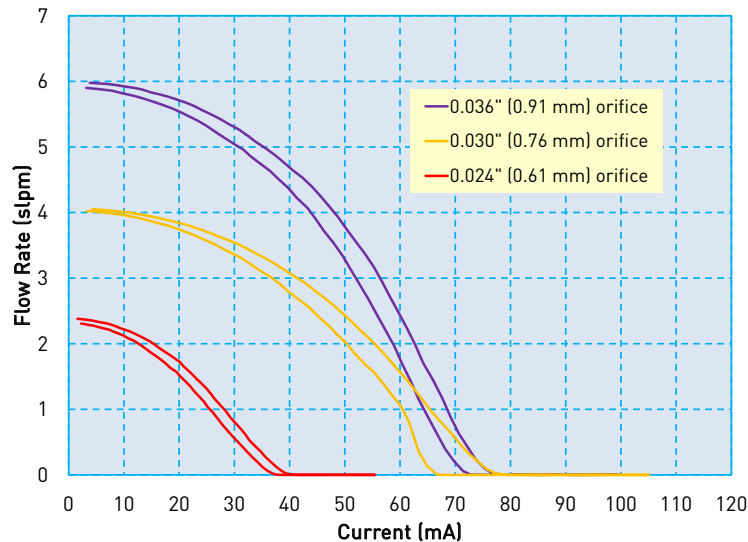

Model 1-3
Lone Wolf Pressure vs Flow Curves

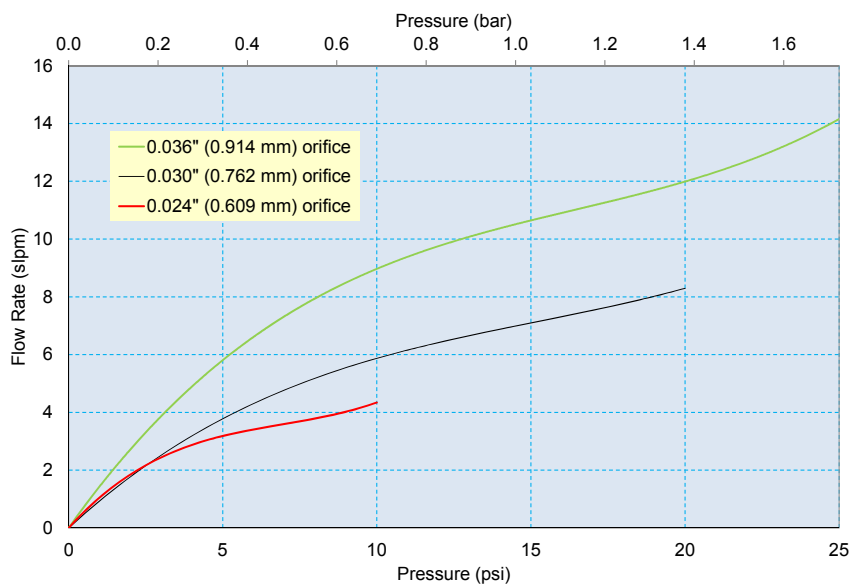

Pressure and Flow Capabilities

Table 1

Model No.	Orifice Diameter in (mm)	Maximum Operating Inlet Pressure psig (bar)	Maximum Operating Pressure Differential psid (bar)
1	0.024 in (0.61mm)	0-25 psig (1.72 bar)	10 psid (0.69 bar)
2	0.030 in (0.76mm)	0-25 psig (1.72 bar)	20 psid (1.37 bar)
3	0.036 in (0.91mm)	0-25 psig (1.72 bar)	25 psid (1.72 bar)

Lone Wolf Thermally Compensated Proportional Valve

Lone Wolf Sizing Charts

Model 1 – 0.024" (0.61 mm) Orifice

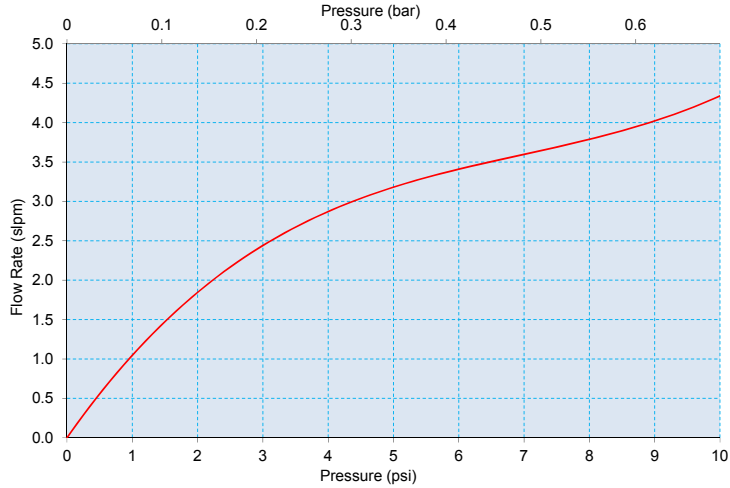

Model 2 – 0.030" (0.76 mm) Orifice

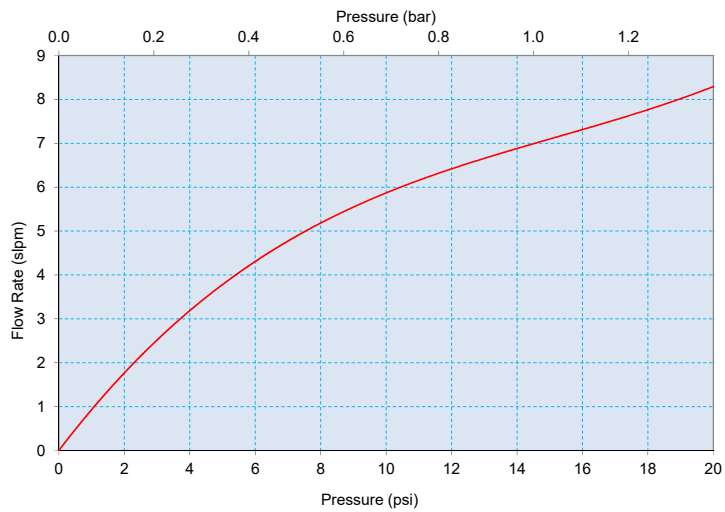

Model 3 – 0.036" (0.91 mm) Orifice

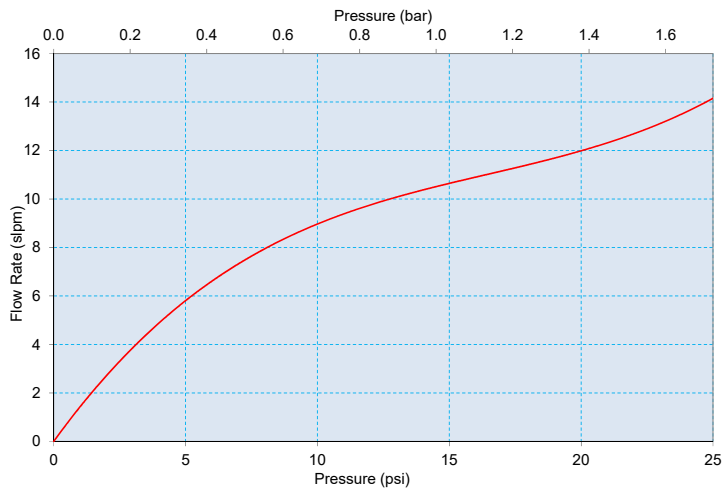

Lone Wolf Thermally Compensated Proportional Valve

Pneumatic Interface

**Lone Wolf
Manifold Mount**



**Lone Wolf
Barbed**



Mechanical Integration Dimensions

Lone Wolf Manifold Mount and Barbed Body Basic Valve Dimensions

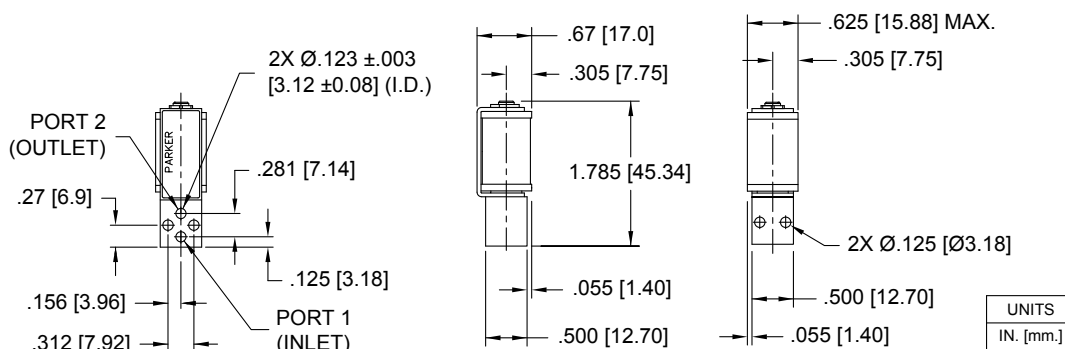

Optional Barb Dimensions

1/8" (3 mm) Barbs

(For 1/8" (3 mm) I.D. Tubing)

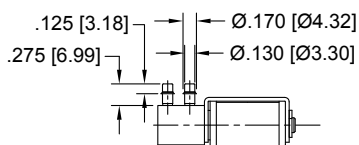

Lone Wolf Thermally Compensated Proportional Valve

Electrical Interface

Coil Type: Wire Leads (for Terminal Block Connection)

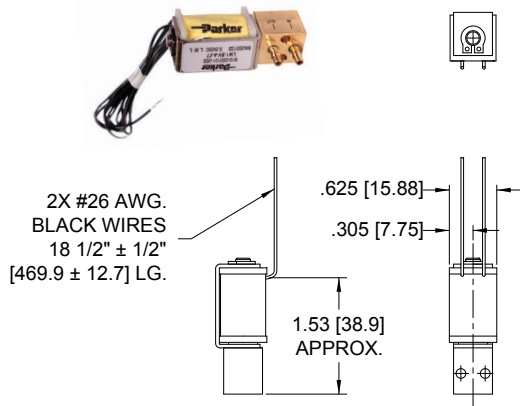

Coil Type: Quick Connect Spade (for Female Spade Terminal Connection)

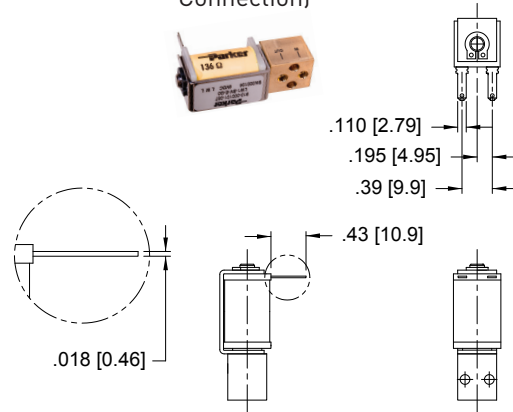

Coil Type: 4 PC Pins (For PCB solder mount connection)

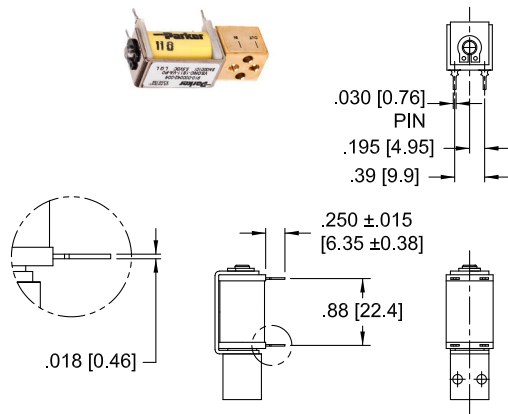

PCB Pin Layout (Coil Type 4 PC Pin)

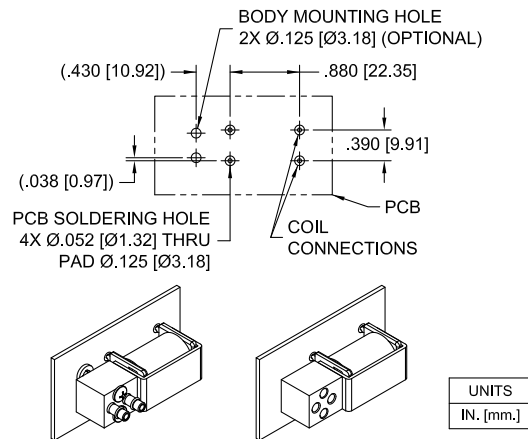

Electrical Requirements

Table 2

Model 1 0.024" (0.61 mm) orifice			Model 2 0.030" orifice (0.76 mm)			Model 3 0.036" (0.91 mm) orifice		
Minimum Available Voltage (VDC)	Nominal Coil Resistance @ 20° C (Ohms)	Input Current for Full Shut Off (mA)	Minimum Available Voltage (VDC)	Nominal Coil Resistance @ 20° C (Ohms)	Input Current for Full Shut Off (mA)	Minimum Available Voltage (VDC)	Nominal Coil Resistance @ 20° C (Ohms)	Input Current for Full Shut Off (mA)
3.0	11	184	4.0	11	254	5.0	11	335
4.0	23	128	5.0	23	177	8.0	23	233
5.0	47	92	7.5	47	127	11.0	47	168
6.0	68	76	9.0	68	105	13.0	68	138
9.0	136	55	13.0	136	76	19.0	136	100
13.0	274	40	19.0	274	55	28.0	274	73
18.0	547	28	26.0	547	40	39.0	547	52
24.0	1094	20	36.0	1094	27	54.0	1094	36

Lone Wolf Thermally Compensated Proportional Valve

Installation and Use

Typical Valve Set-up

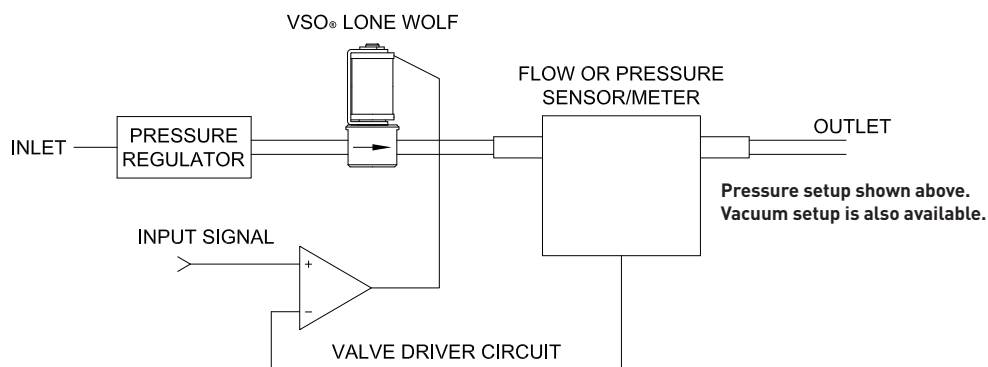

Valve Electrical Control

Basic Control:

The Lone Wolf valve can be controlled by either voltage or current; however, it is highly recommended that current control be employed to ensure the most repeatable valve flow performance.

PWM Control:

For PWM control, the signal applied to the valve should have a frequency between 5-12kHz. Optimum frequency will be application dependent.

Suggested Lone Wolf Current Driver Schematic

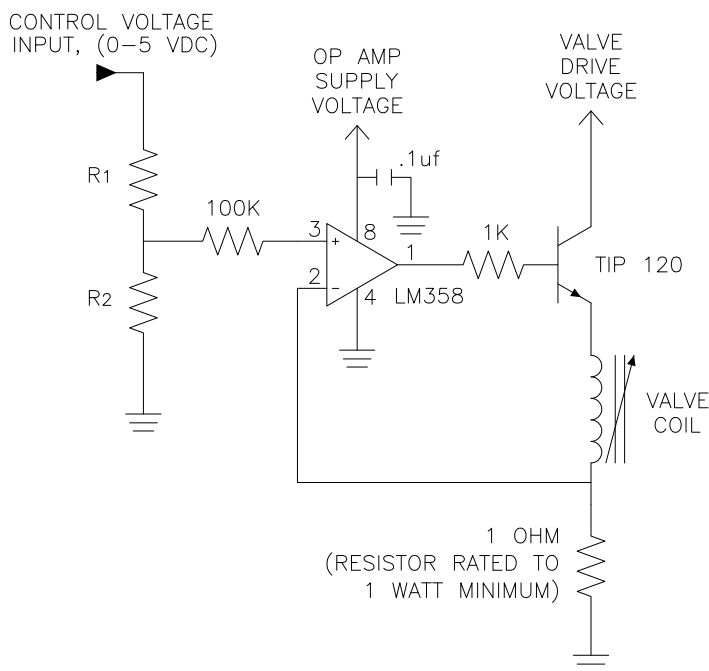

This simple current driver circuit draws only 1 mA at the input control (0-5VDC) and provides control for any Lone Wolf configuration regardless of valve voltage or resistance.

Table 3 (next page) describes the recommended R1 and R2 resistor values based upon the full shut-off current.

Lone Wolf Thermally Compensated Proportional Valve

Table 3: Selectable Resistor Values for a Low Current (1mA) LM358-Based Current Driver

Model 1 0.024" (0.61 mm) orifice					
Voltage Supplied to Valve Coil (Reference)	Valve Drive Voltage (VDC)	Nominal Coil Resistance @ 20°C (Ohms)	Input Current for Full Shut Off (mA)	R1 (Ohms)	R2 (Ohms)
3.0	5.0	11	184	4816	184
4.0	6.0	23	128	4872	128
5.0	7.0	47	92	4908	92
6.0	8.0	68	76	4924	76
9.0	11.0	136	55	4945	55
13.0	15.0	274	40	4960	40
18.0	20.0	547	28	4972	28
24.0	26.0	1094	20	4980	20

Model 2 0.030" (0.76 mm) orifice					
Voltage Supplied to Valve Coil (Reference)	Valve Drive Voltage (VDC)	Nominal Coil Resistance @ 20°C (Ohms)	Input Current for Full Shut Off (mA)	R1 (Ohms)	R2 (Ohms)
4.0	6.0	11	254	4746	254
5.0	7.0	23	177	4723	177
7.5	9.5	47	127	4873	127
9.0	11.0	68	105	4895	105
13.0	15.0	136	76	4924	76
19.0	21.0	274	55	4945	55
26.0	28.0	547	40	4960	40
36.0	38.0	1094	27	4973	27

Model 3 0.036" (0.91 mm) orifice					
Voltage Supplied to Valve Coil (Reference)	Valve Drive Voltage (VDC)	Nominal Coil Resistance @ 20°C (Ohms)	Input Current for Full Shut Off (mA)	R1 (Ohms)	R2 (Ohms)
5.0	7.0	11	335	4665	335
8.0	10.0	23	233	4767	233
11.0	13.0	47	168	4832	168
13.0	15.0	68	138	4862	138
19.0	21.0	136	100	4900	100
28.0	30.0	274	73	4927	73
39.0	41.0	547	52	4948	52
54.0	56.0	1094	36	4964	36

Lone Wolf Thermally Compensated Proportional Valve

Installation and Use

Recommended Manifold Dimensions & Design

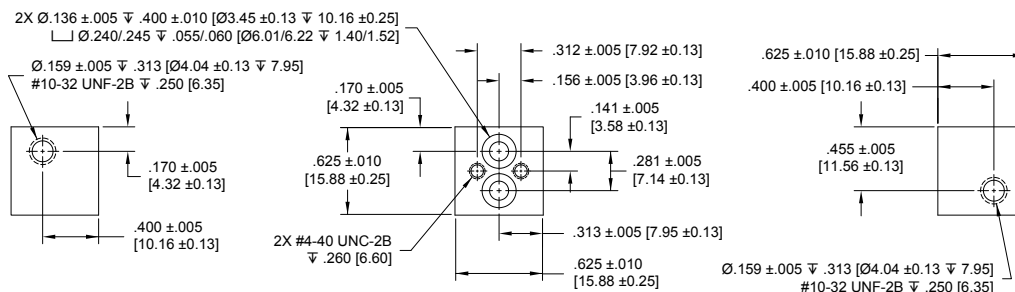

Accessories

O-Ring (Manifold Seal) Dimensions
 190-007024-002 [2 required for each valve]

I.D. = Ø.114 ±.005 [Ø2.90 ±0.13]
 W = .070 ±.003 [1.78 ±0.08]
 O.D. = Ø.254 [Ø6.45] REFERENCE

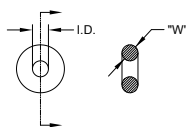

Screw 4-40 x 5/8" Pan Head, Phillips
 191-000115-010 [2 required for each valve]



Ordering Information

Sample Part ID	LW	1	B	V	A	F	8
Description	Series	Model Number: Max Operating Pressure / Orifice Size	Body/ Material	Elastomer	Coil Resistance*	Electrical Interface	Pneumatic Interface
Options	LW	1: 0-10 psi / 0.024" (0.61 mm) 2: 0-20 psi / 0.030" (0.76 mm) 3: 0-25 psi / 0.036" (0.91 mm)	B: Brass	V: FKM	A: 11 Ohm B: 23 Ohm C: 47 Ohm D: 68 Ohm E: 136 Ohm F: 274 Ohm G: 547 Ohm H: 1094 Ohm	F: Wire Leads, 18" (45.7 cm) P: PC Board Mount, 4 Pin Q: Quick Connect, Spade	0: Manifold Mount 1: Manifold Mount w/screens 8: 1/8" (3 mm) Barbs

*See Table 2: Electrical Requirements to properly reference a coil resistance to the appropriate control voltage for each model

Accessories	
190-007024-002: O-ring, FKM, 0.114" ID x 0.070" Thick*	* Not supplied with the valve. Used as a seal between the valve body and manifold.
191-000115-010: Screw 4-40 x 5/8" Pan Head **	**Not supplied with the valve. Used to mount the valve to a manifold.



NOTE: In order to provide the best possible solution for your application, please provide the following requirements when contacting Applications Engineering:

- Media, Inlet & Outlet Pressures
- Minimum Required Flow Rate
- System Supply Voltage
- Media & Ambient Temperature Range

Please click on the Order On-line button (or go to www.parker.com/precisionfluidics/lonewolf) to configure your Lone Wolf Thermally Compensated Proportional Valve. For more detailed information, visit us on the Web, or call and refer to Performance Spec. #790-002130-001 and Drawings #890-003079-001 and #890-003079-004.

Parker Hannifin Precision Fluidics Division reserves the right to make changes. Drawings are for reference only.

PPF-MPV-002/US March 2019

For more information call +1 603 595 1500 or email ppfinfo@parker.com
 Visit www.parker.com/precisionfluidics

