



VC series resistant to ammonia

Technical data

Humidity

measuring range 0...100%rh
 accuracy (MB 20...90% rh at 15...40°C) ±3% rh
 accuracy < 20% rh and > 90% rh ±5% rh
 at <15°C, >40°C <0.1%/K additional
 response time (at calm air) < 20 s

Temperature

measuring element (ref. DIN EN 60751) Pt 100 cl. B
 measuring range -30...+70°C
 accuracy
 0...1V (-27...70°C) ±0,2 K
 0...10V (-29...70°C) ±0,2 K
 4...20mA ±0,3 K
 at <10°C, >40°C ±0.007K/K additional

Other data

ambient temperature -40...+80°C
 degree of protection sensor/electronics IP 54/IP 65
 operating voltage:
 current output 12...30V DC
 voltage output (0...10V) 15...30V DC
 voltage output (0...1V) 6...30V DC
 load resistance (0...10V, 0...1V) ≥10kΩ/≥2 kΩ
 load (current-output) acc. diagramm
 power consumption
 0...10V, 2 x 0...1V < 5 mA
 0...1V <1 mA
 minimum air speed
 2 x 4...20mA ≥1.5 m/s
 4...20 mA, 2 x 0...10 V ≥1 m/s
 0...10V, 2 x 0...1V ≥0.5 m/s
 self-heating coefficient Pt100 (v=2 m/s in air) 0.2 K/mW
 material high-grade steel

Directive about electromagnetic compatibility 2014/30/EU

DIN EN 61326-1 issue 07/13
 DIN EN 61326-2-3 issue 07/13

Product info sheet no. C 4.4

Humidity-/temperature sensors

special sensors for use in gases containing „ammonia“

Description

MELA®-Humidity-/temperature sensors in the VCx/11 series are compact sensors in a rod-type design. They are available with a 1.5 m connecting cable for measuring the relative humidity or the relative humidity and the temperature in air and other gases. The sensor can be used in areas contaminated with a variety of pollutants (e.g. ammonia), without damaging the element or falsifying its measuring value. However the sensor is not resistant to all harmful substances, you are recommended to contact the manufacturer in special cases.

All the sensors in the series are equipped with **ZE 26-type membrane filters**. For special applications other filters can be used as well (product info sheet no. F 5.1).

Use of capacitive **MELA®-humidity sensor elements** is a guarantee of:

- high long-term stability
- almost linear characteristic curve
- good dynamic performance
- resistance to dew formation
- small hysteresis.

Type version

measured variable	output	series VC with cable
F rel. humidity	0...1V	FVC 1/11
	0...10V	FVC 2/11
	4...20mA	FVC 3/11
C r.h. + Pt100	0...1V Pt100	CVC 1/11
	0...10V Pt100	CVC 2/11
	4...20mA Pt100	CVC 3/11
K r.h. + temp.	2 x 0...1V	KVC 1/11
	2 x 0...10 V	KVC 2/11
	2 x 4...20mA	KVC 3/11
weight		150 g

special versions available on request

Tolerance validity range for humidity

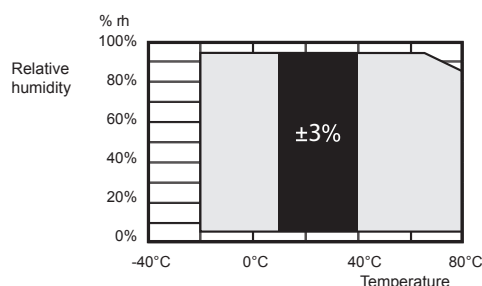

Application recommendations

Install the **MELA®-humidity/-temperature sensors** at a place in the room, plant or equipment where characteristic levels of humidity occur. Mounting close to heaters, windows, or outside walls should be avoided.

The specified minimum air speed and - with current output - the load according to the operating voltage (diagram) should be complied with in the case of the VC series. Deviations may lead to additional measuring faults resulting of the self-heating of the sensor (clocked operation will help to avoid this).

Install the sensor horizontally or with the sensor element pointing downwards. Avoid water ingress. Dew formation and splashes do not damage the sensor, although corrupted measurement readings are recorded until all the moisture on and directly around the sensor element has dried up.

Dust does not cause any harm to the humidity sensor, however, it does affect dynamic performance. We advise you to use a **ZE13-type sintered filter** at high air speeds ($\geq 8\text{m/s}$). As additional protection against rainfall and sunlight we recommend that you use the **ZA 161/1-type weather guard** (product info sheet F 5.1).

Do not touch the highly sensitive sensor element. For mounting supports we recommend a **console type 20.009** and an **attachment plate type ZA 25** (Product info sheet No. F5.1). In order to check functioning in the place of installation, we recommend that you use the **ZE 31/1-type MELA®-humidity standard** (product info sheet no. F 5.2).

Please consult the **application instructions for the sensing elements** (product info sheet no. A 1) or check with the manufacturer for further information which you need to bear in mind when using humidity sensors with capacitive sensing elements.

Load at current output

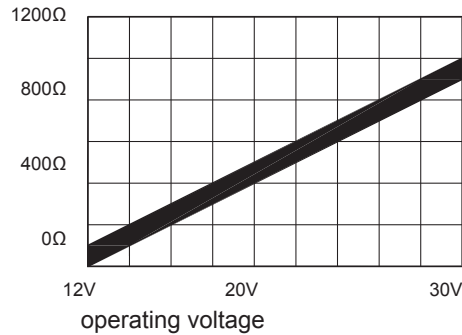

Humidity working range

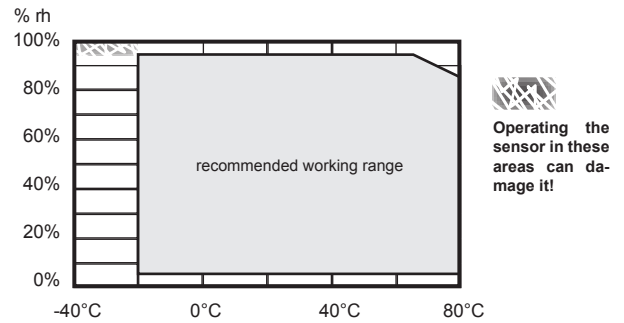

Dimensions

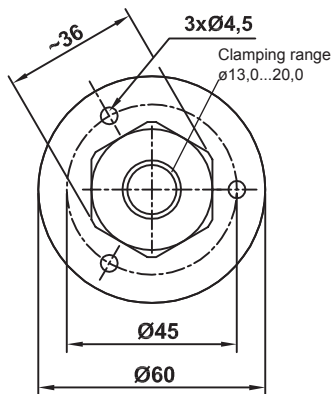

Type ZA25
for duct mounting

(please order separately)

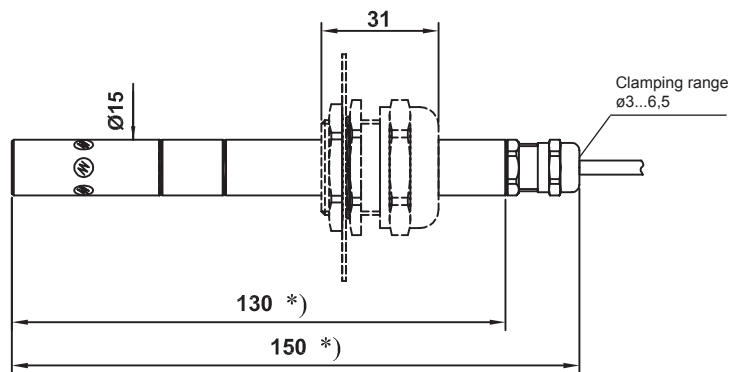

VC series

Connection diagram

Humidity/-temperature sensors

Special sensors in a high-grade steel housing for use in gases containing ammonia

VC series

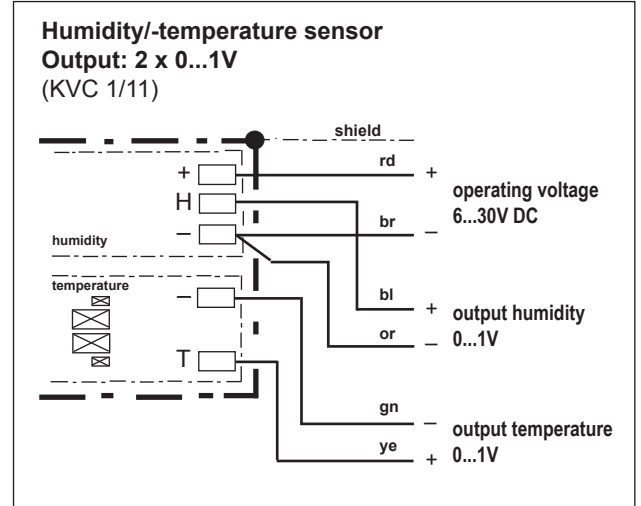
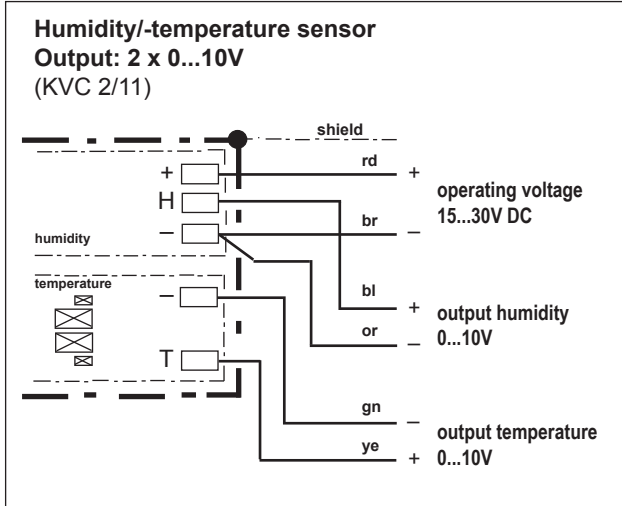

The electrical connection must only be carried out by properly qualified personnel.

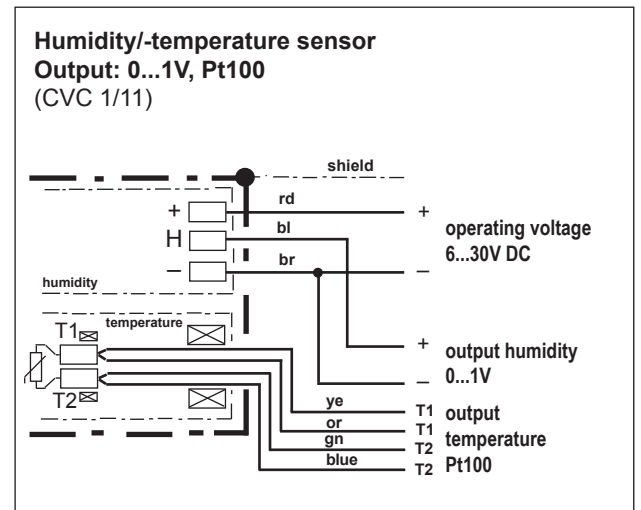
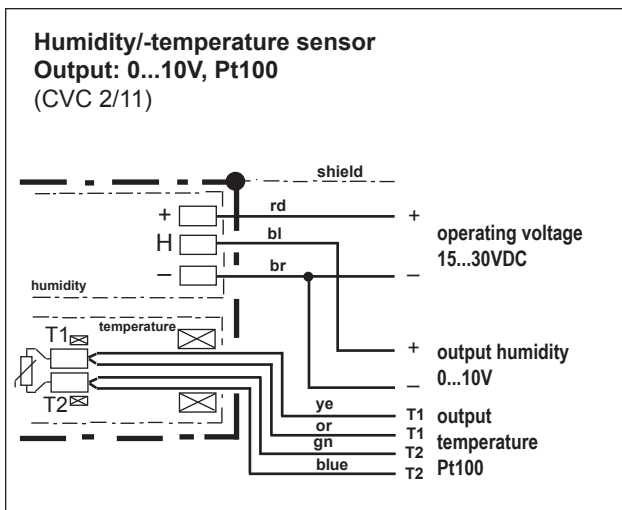
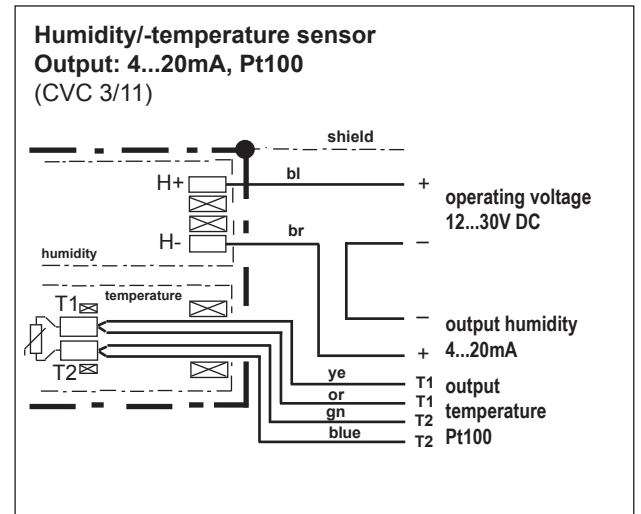
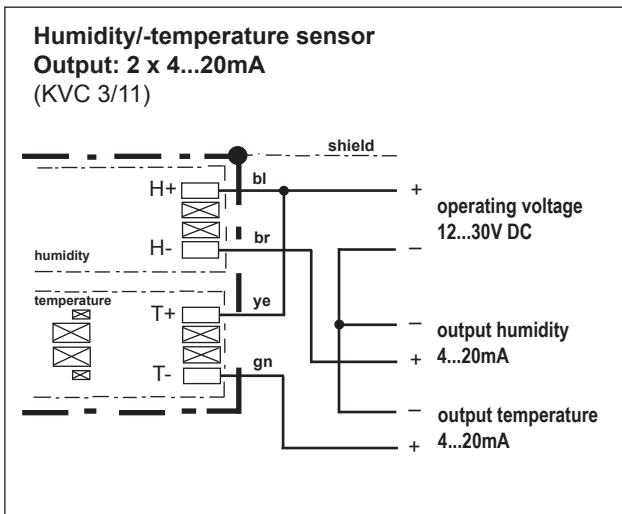



Connection diagram

Humidity/-temperature sensors

Special sensors in a high-grade steel housing for use in gases containing ammonia

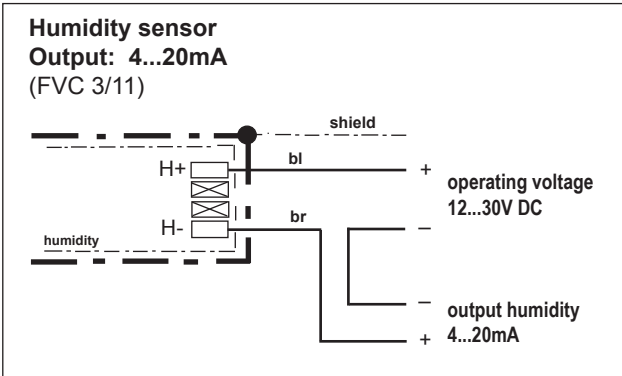
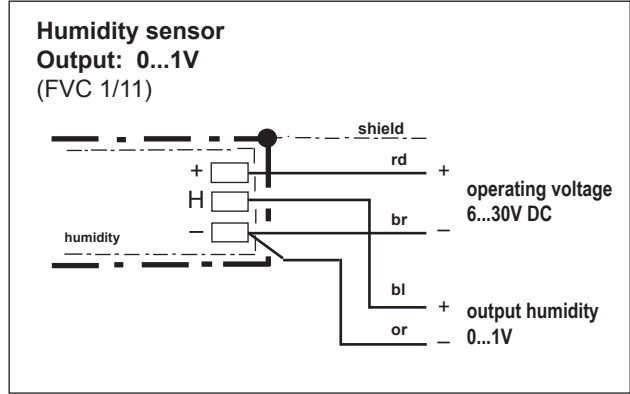
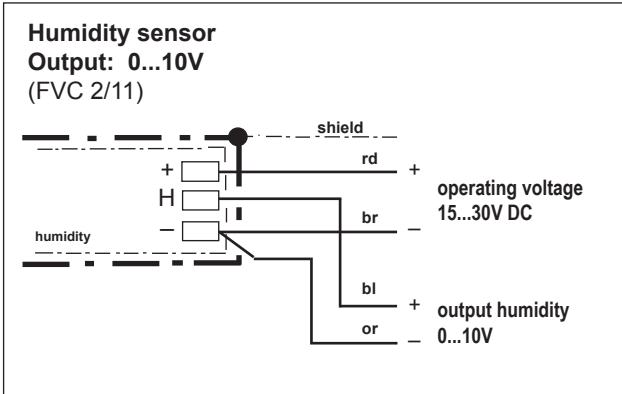
VC series



 The electrical connection must only be carried out by properly qualified personnel.