

Sensotox 2

Remote Gas Detector with Display and Relays for flammable, toxic gases, oxygen and VOCs.



01 PRODUCT DESCRIPTION

The Sensotox 2 uses different sensor technologies to achieve a variety of configurations for flammable, toxic, oxygen gases and VOCs; can be connected as a 4-20 mA transmitter or as a ModBus RS 485 transmitter, enabling up to 256 sensors to be connected at the same central.

Optionally it also incorporates a display for showing the readings, adjustment by magnetic keyboard eliminating the need to open the box, leds and alarm relays for local action, which makes turning it into a detector-central. It can also be equipped with optional wireless modem to transmit data remotely without the need to install cables from the sensor to the control panel.

The ModBus sensor network connected to a GasVisor control unit will monitor the status of each of the sensors to indicate alarm and sensor status conditions, with a wide variety of controls, indications and options. It also has a 4-20 mA output to connect to GasVisor panels with up to 8 analog inputs, or to the user-owned control system.

02 KEY FEATURES

- Robust and reliable
- Flexible output options
- Catalytic, Infrared, Electrochemical Photoionization (PID) sensor options
- Explosion proof case
- ATEX II 2G Ex db IIC T6 Gb
- Two alarm relays*
- Non-intrusive one-man calibration with magnets*
- Backlight display on alarm*
- 4-20 mA analog output
- ModBus RS485 digital output
- Addressable or independent
- Wireless modem 868MHz*
- Datalogging capacity as it forms part of a system with GasVisor and SenView software
- Correction factors for the LEL sensor

*Option

03 TECHNICAL SPECIFICATIONS

Power Supply	12 – 30 Vdc 4 – 20 mA (3 wires) and ModBus RS 485 (4 wires)
Outputs	Low alarm relay and High alarm 1A @ 24V Relays inhibition during adjustment
Display	4-digit LCD, backlight Working: Green LED Alarm: Red LED and status warning on display Fault: Orange LED and status warning on display
Box material	Cast aluminum / Stainless steel
Coating	Chemical resistant epoxy paint
Protection	IP - 68
Cable Entry	2 x ½" NPT
Weight	1,6 kg
Temperature	-10°C to +60°C (-20°C to +60°C for blind units)
Humidity	0 to 99% RH (non-condensation)
Certification	II 2G Ex db IIC T6 Gb / II 2D Ex tb IIC T85°C Db

04 CONNECTION SCHEME

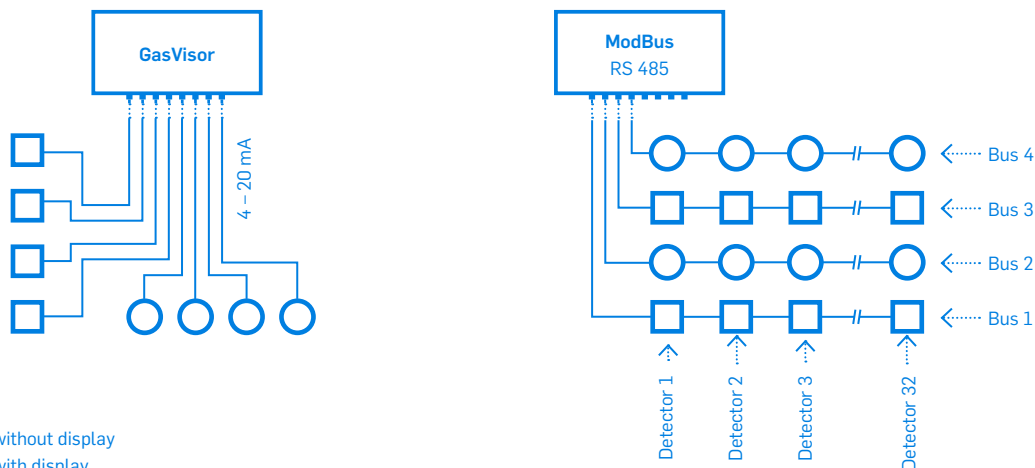

- Sensotox 2 without display
- Sensotox 2 with display

05 ORDERING INFORMATION*

Reference	Gas	Range	Sensor
S2-001-XY	O ₂	0 – 30% vol.	Electrochemical
S2-002-XY	CO	0 – 1.000 ppm	Electrochemical
S2-003-XY	H ₂ S	0–100 ppm	Electrochemical
S2-004-XY	NO	0–250 ppm	Electrochemical
S2-005-XY	NO ₂	0–20 ppm	Electrochemical
S2-006-XY	Cl ₂	0 – 10 ppm	Electrochemical
S2-007-XY	SO ₂	0 – 20 ppm	Electrochemical
S2-008-XY	NH ₃ (standard range)	0 – 300 ppm	Electrochemical
S2-009-XY	NH ₃ (high range)	0 – 1.000 ppm	Electrochemical
S2-010-XY	CH ₄ Vol. (IR high range)	0 – 100% vol.	Infrared
S2-011-XY	CO ₂	0 – 10.000 ppm	Infrared
S2-012-XY	CO ₂	0 – 50.000 ppm	Infrared
S2-013-XY	CO ₂	0 – 100% vol.	Infrared
S2-014-XY	COV	0,01 – 20,0 ppm	PID
S2-015-XY	COV	0,1 – 200 ppm	PID
S2-016-XY	COV	0 – 2.000 ppm	PID
S2-017-XY	PH ₃	0 – 20 ppm	Electrochemical
S2-018-XY	H ₂ S (high range)	0 – 2.000 ppm	Electrochemical
S2-019-XY	L.E.L. (IR)	0 – 100% L.E.L.	Infrared
S2-020-XY	L.E.L.	0 – 100% L.E.L.	Pellistor
S2-021-XY	ETO	0 – 10 ppm	Electrochemical
S2-022-XY	HCN	0 – 50 ppm	Electrochemical
S2-023-XY	HF	0 – 10 ppm	Electrochemical
S2-024-XY	H ₂	0 – 2.000 ppm	Electrochemical
S2-025-XY	O ₃	0 – 10 ppm	Electrochemical
S2-026-XY	HCl	0 – 50 ppm	Electrochemical
S2-027-XY	HCHO	0 – 10 ppm	Electrochemical
S2-028-XY	CH ₃ SH	0 – 10 ppm	Electrochemical
S2-029-XY	C ₂ H ₃ Cl	0 – 20 ppm	Electrochemical
S2-030-XY	ClO ₂	0 – 10 ppm	Electrochemical