



---

## Laser Level Transmitter

### TL400-V / TL400-I

USER GUIDE – V3.2x C

**NOVUS**  
We Measure, We Control, We Record



Recommended for devices with firmware version V3.2x and higher.



1	SAFETY ALERTS.....	4
2	PRESENTATION.....	5
3	TL400-V: IDENTIFICATION.....	6
3.1	OVERVIEW.....	6
3.2	IDENTIFICATION.....	6
3.3	TL400-V.....	6
4	TL400-I: IDENTIFICATION.....	7
4.1	OVERVIEW.....	7
4.2	IDENTIFICATION.....	7
4.3	TL400-I.....	7
5	INSTALLATION.....	8
5.1	ELECTRICAL INSTALLATION.....	8
5.1.1	INSTALLATION RECOMMENDATIONS.....	8
5.1.2	TL400-V: ELECTRICAL CONNECTIONS.....	8
5.1.2.1	ANALOG INPUT CONNECTION.....	8
5.1.3	TL400-I: ELECTRICAL CONNECTIONS.....	8
5.1.3.1	ANALOG INPUT CONNECTION.....	9
5.1.4	DIMENSIONS.....	10
5.1.4.1	TL400-V.....	10
5.1.4.2	TL400-I.....	10
5.1.4.3	DIAMETER FOR LASER PASSAGE.....	10
5.1.4.4	5-HOLE TO 4-HOLE ADAPTER.....	11
5.2	MECHANICAL INSTALLATION.....	11
5.2.1	TL400-V WITH AND WITHOUT ADAPTER.....	12
5.2.2	TL400-I WITH AND WITHOUT ADAPTER.....	12
5.2.3	ADAPTER AND GASKET.....	12
5.2.4	INSTALLATION EXAMPLES.....	13
6	RECOMMENDATIONS FOR USE AND APPLICATION.....	14
6.1	SUNLIGHT.....	14
6.2	LOW LEVELS IN TRANSPARENT LIQUIDS.....	14
6.3	REFLECTIVE WALLS NEAR THE SENSOR.....	15
6.4	NARROW TANKS.....	15
6.5	TANKS WITH SMOKE, DUST OR OPAQUE STEAM.....	16
6.6	SMALL TANKS.....	16
6.7	CHEMICAL COMPATIBILITY.....	16
6.8	INCLINED MEASURING SURFACE.....	16
7	DEFINITIONS.....	17
7.1	TECHNICAL TERMINOLOGY.....	17
7.2	SOME TYPES OF TANKS.....	17
8	SIGNOW: SOFTWARE AND APP.....	19
8.1	BLUETOOTH INTERACE.....	19
8.2	SOFTWARE SIGNOW.....	19
8.3	PAIRING TL400 WITH YOUR SOFTWARE.....	19
8.4	PAIRING TL400 WITH YOUR SMARTPHONE.....	20
8.5	WIZARD MODE.....	21
8.6	DEMOSTRATION MODE.....	22
8.7	ADVANCED MODE.....	22
8.7.1	INFORMATION.....	22
8.7.2	GENERAL CONFIGURATION.....	23
8.7.3	ADVANCED CONFIGURATION.....	24
8.7.3.1	INPUT.....	24
8.7.3.2	OUTPUT.....	25
8.7.3.3	ADVANCED FILTER.....	27
8.7.3.4	SECURITY.....	28
8.7.4	COMMUNICATION.....	29
8.7.5	DIAGNOSTIC.....	29
8.7.6	FIRMWARE UPDATE.....	32
9	ADVANCED FILTER.....	33

9.1	WHEN USE THE ADVANCED FILTER.....	33
9.2	A MORE DETAILED EXPLANATION OF THE ADVANCED FILTER PARAMETERS.....	33
9.2.1	«SIZE OF THE MAIN VECTOR» PARAMETER.....	33
9.2.2	«SIZE OF THE DISTANCE VECTOR» PARAMETER.....	33
9.2.3	«MEDIAN INDEX» PARAMETER.....	34
9.2.4	«MEDIAM SIZE» PARAMETER.....	34
9.2.5	«ACCEPTANCE PERCENTAGE» PARAMETER.....	34
9.2.6	«PERCENTAGE INCREASE» PARAMETER.....	34
9.2.7	«ACCEPTANCE COUNTS» PARAMETER.....	34
9.2.8	«FIRST-ORDER CONSTANT» PARAMETER.....	35
10	USAGE EXAMPLES.....	36
10.1	EXAMPLE 1: 3-METER HIGH AND 2-METER WIDE WATER TANK.....	36
10.2	EXAMPLE 2: 80 CM OIL TANK.....	36
11	TECHNICAL SPECIFICATIONS.....	37
11.1	TL400-V.....	37
11.2	TL400-I.....	37
11.3	FACTORY DEFAULT.....	38
11.4	CERTIFICATIONS.....	39
12	WARRANTY.....	40

# 1 SAFETY ALERTS

The symbols below are used in the device and throughout this manual to draw the user's attention to valuable information related to device safety and use.

		
<b>CAUTION</b> Read the manual fully before installing and operating the device.	<b>CAUTION OR HAZARD</b> Risk of electric shock.	<b>ATTENTION</b> Material sensitive to static charge. Check precautions before handling.

All safety recommendations appearing in this manual must be followed to ensure personal safety and prevent damage to the instrument or system. If the instrument is used in a manner other than that specified in this manual, the device's safety protections may not be effective.



This product emits radiation in the infrared range and uses LASER technology. It has been developed to meet the class 1 requirements of IEC 60825-1:2014 (Third Edition). Provided that the user follows **NOVUS** recommendations described in this manual, the radiation emission will remain within the limits of class 1. Lenses or any form of optical device should not be used to alter the product performance.

## 2 PRESENTATION

**TL400** is a non-intrusive level transmitter with no moving parts, using an infrared laser technology (~920 nm) that is completely safe to the human eye (LASER CLASS-1). Its measurement principle is based on ToF (Time of Flight), providing an accurate and reliable distance measurement, regardless of the color or transparency of the surface<sup>1</sup>. It can be used to measure from grains and solids to transparent liquids such as water and diesel.

It has a robust housing, withstanding pressures up to 6 bar, and excellent resistance to flammable materials such as diesel, gasoline, or alcohol.

With a measurement capacity up to 4 meters and 1 Hz sampling, **TL400** is an excellent alternative to level sensors based on ultrasonic, capacitive, or floating technology since it does not need to be in contact with the surface to be measured.

The transmitter has a dedicated filter for non-static tank applications based on machine learning algorithms that have been validated in real-life situations and have configurable parameters for specific applications.

The sensor allows you to configure the opening angle, ranging from 15° degrees for irregular tank or reservoir applications to 27° degrees for tanks where the base diameter is half the height to be measured.

**TL400** has a BLE (Bluetooth Low Energy) interface. By using it to pair the equipment with the **SigNow** software or app, available for Windows computers and Android and iOS smartphones, you can:

- Configure the analog output, according to the specific application
- Configure the opening angle of the sensor
- Customize the tank with up to 20 points in level percentage
- Perform sensor diagnostics in real time
- Configure the dynamic filter based on the application
- Update the firmware to the most current version, which will always be available on **NOVUS'** website

The sensor can retransmit the analog output in **Level**, **Volume**, or **Distance**. Level and distance are set in your preferred unit (mm, cm, m, inches, or feet) and volume is always displayed in percent.

---

<sup>1</sup> In sunlit environments or in small to medium sized tanks that have reflective walls, the sensor may have difficulty to make an accurate measurement. See recommendations for use and application.

### 3 TL400-V: IDENTIFICATION

#### 3.1 OVERVIEW

The housing of the equipment is made of polycarbonate, an extremely resistant material, and was built to meet the IP68 protection index. It has a gasket in NBR material.



Figure 1

TL400-V has an adapter that allows it to be installed in tanks with 4 holes. This adapter must be purchased separately:

- 4-hole adapter for TL400 (Order code: 8802100300)

#### 3.2 IDENTIFICATION

The identification label, located on the top of the housing, shows the model, serial number, and product code. To make it easier to see the serial number, you can also scan the QR Code.

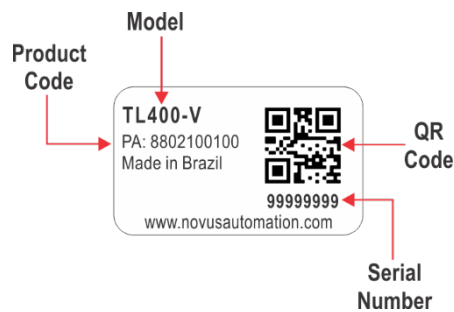

Figure 2

#### 3.3 TL400-V

TL400-V is suitable for vehicle installation. It has a cable with a Superseal connector.



Figure 3

## 4 TL400-I: IDENTIFICATION

### 4.1 OVERVIEW

The housing of the equipment is made of polycarbonate, an extremely resistant material, and was built to meet the IP68 protection index. It has a gasket in NBR material.



Figure 4

TL400-I has an adapter that allows it to be installed in tanks with 4 holes. This adapter must be purchased separately:

- 4-hole adapter for TL400 (Order code: 8802100300)

### 4.2 IDENTIFICATION

The identification label, located on the top of the housing, shows the model, serial number, and product code. To make it easier to see the serial number, you can also scan the QR Code.

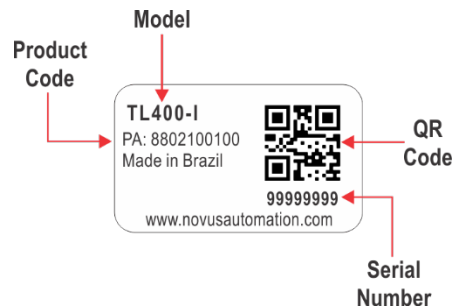

Figure 5

### 4.3 TL400-I

TL400-I is suitable for industrial installation. It can be installed on a tank lid and has a cable with an M12 connector.



Figure 6

## 5 INSTALLATION

### 5.1 ELECTRICAL INSTALLATION

#### 5.1.1 INSTALLATION RECOMMENDATIONS

- Electronic and analog signal drivers must run the plant separately from the output and power leads. If possible, in grounded conduits.
- The power supply for the electronic instruments must come from a proper power grid for instrumentation.
- It is recommended to use RC FILTERS (noise suppressors) in contactor coils, solenoids, etc.
- In control applications, it is essential to consider what can happen when any part of the system fails. The device's internal security features do not guarantee full protection.

#### 5.1.2 TL400-V: ELECTRICAL CONNECTIONS

TL400-V must be connected in accordance with the following figure:

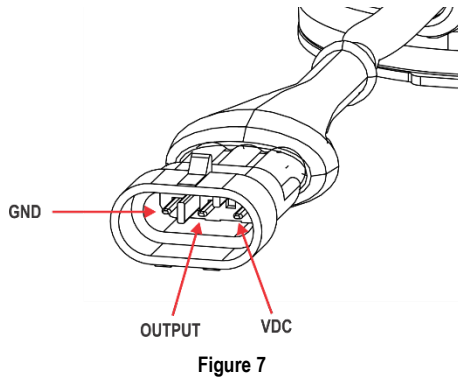

##### 5.1.2.1 ANALOG INPUT CONNECTION

Below is an example of how to connect the output to an analog input:

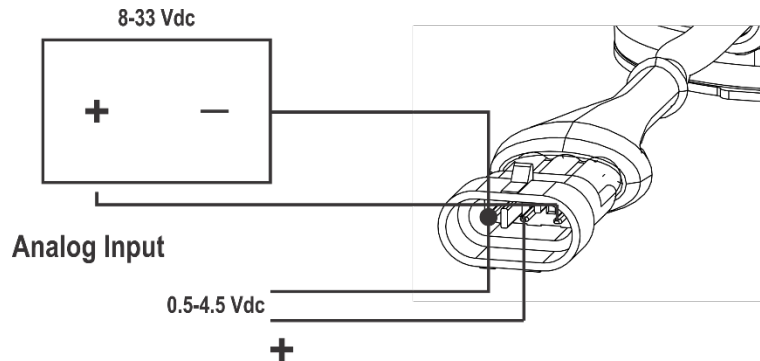

#### 5.1.3 TL400-I: ELECTRICAL CONNECTIONS

The output connector is a M12 type with the following wiring connections:

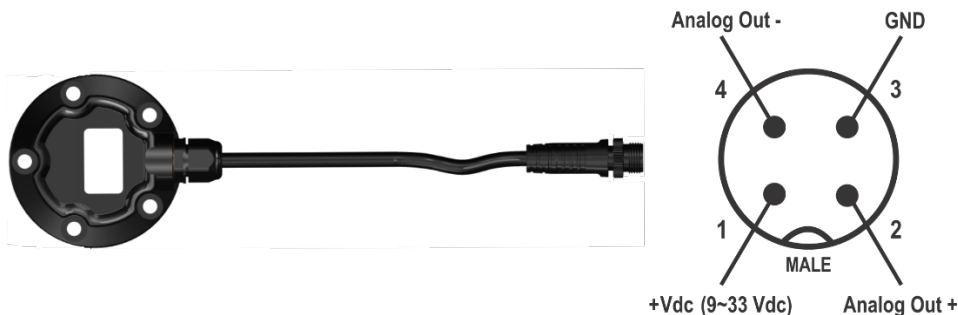
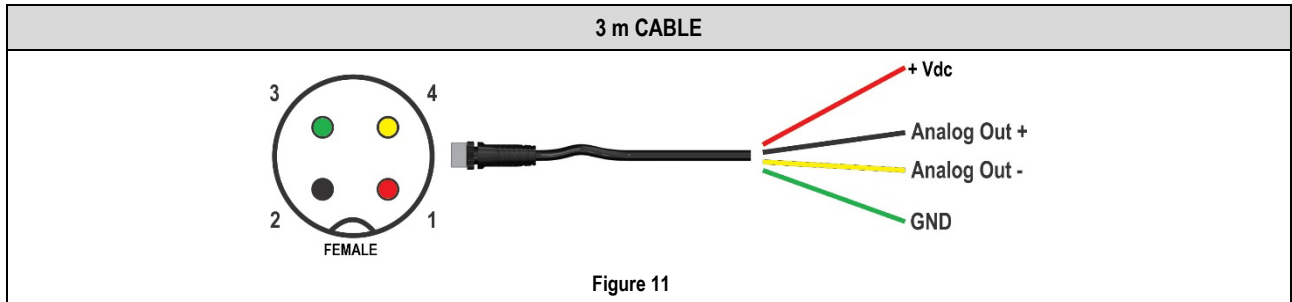
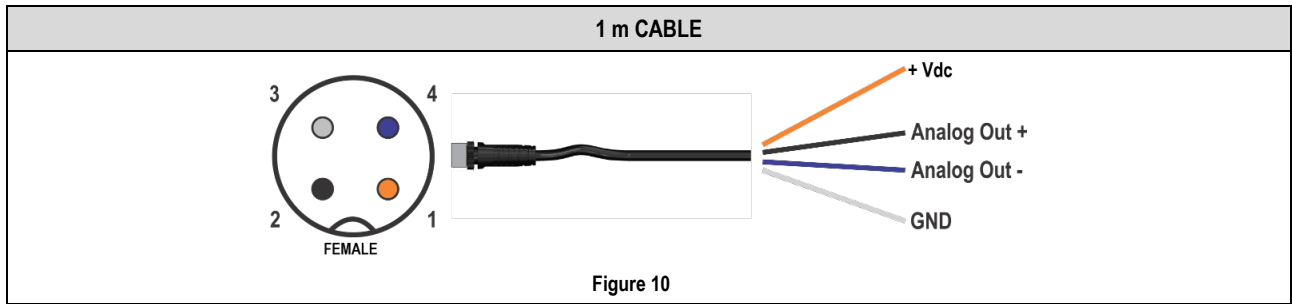

Figure 9

TL400-I has 2 accessory cables, which can be purchased separately:

- 1 m PVC sensor cable 4-pin | M12 female connector (Order code: 8806065000)
- 3 m PVC sensor cable 4-pin | M12 female connector (Order code: 8806065100)

The connection to the M12 female connector must be made in accordance with the following wiring connections:



**5.1.3.1 ANALOG INPUT CONNECTION**

Below is an example of how to connect the output to an analog input:

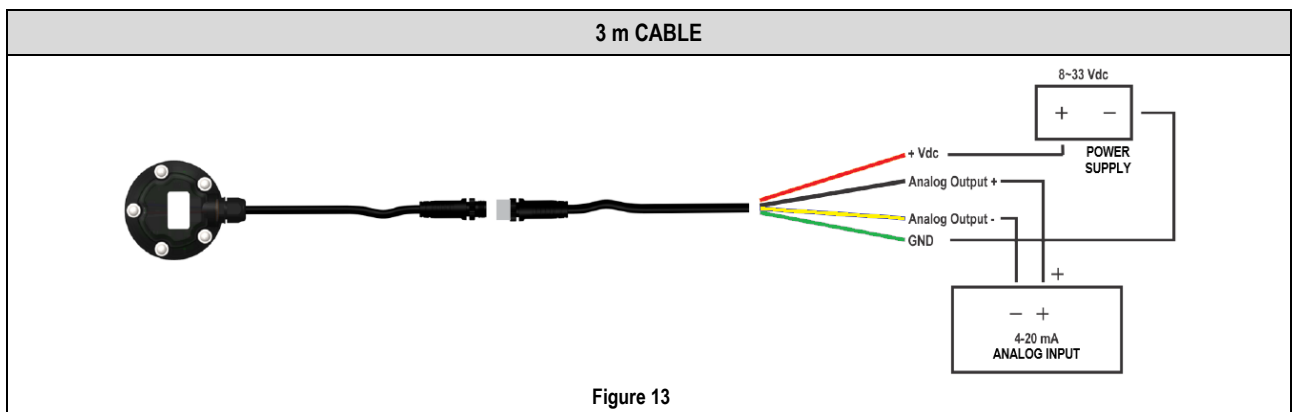
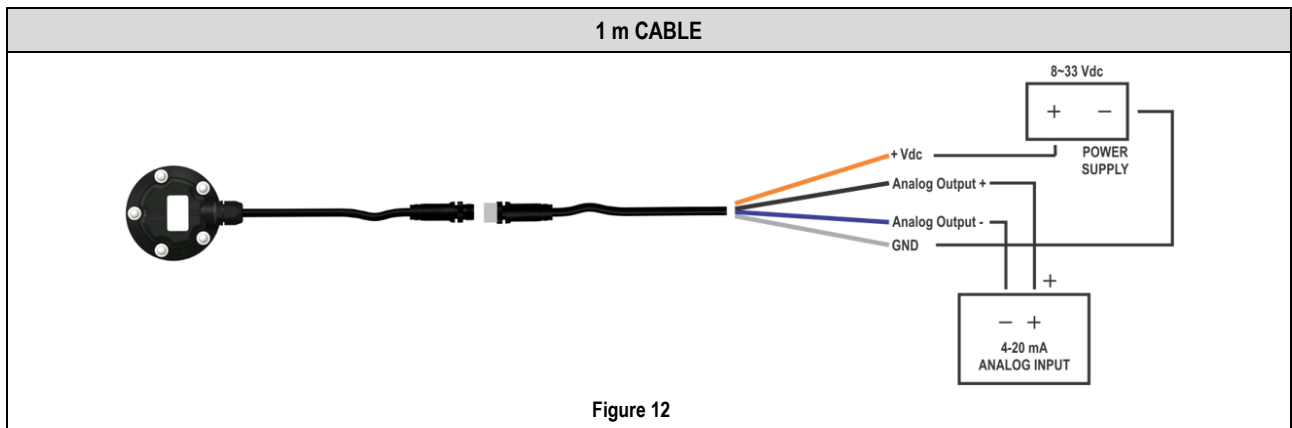

## 5.1.4 DIMENSIONS

### 5.1.4.1 TL400-V

The figures below show the dimensions of the TL400-V and the gasket:

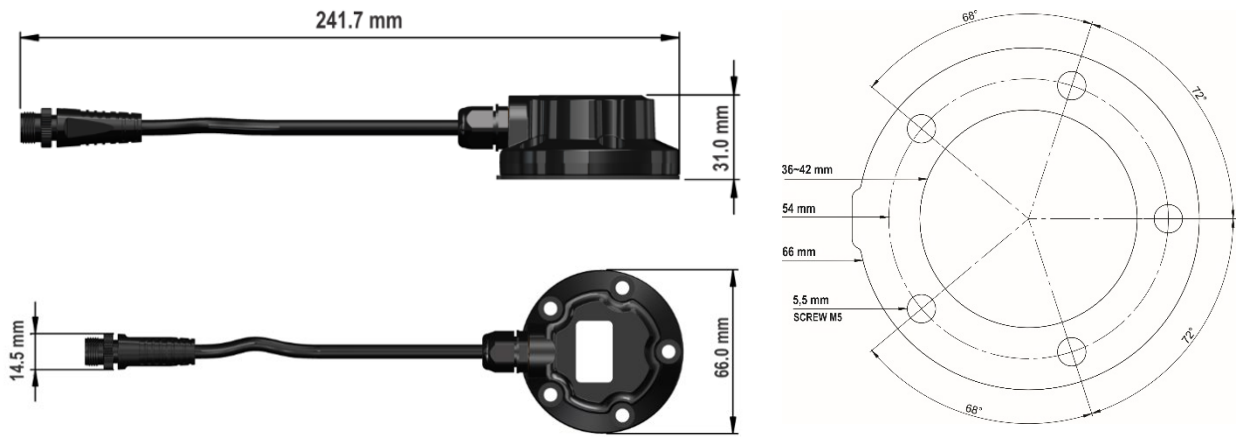

Figure 14

### 5.1.4.2 TL400-I

The figures below show the dimensions of the TL400-I and the gasket:

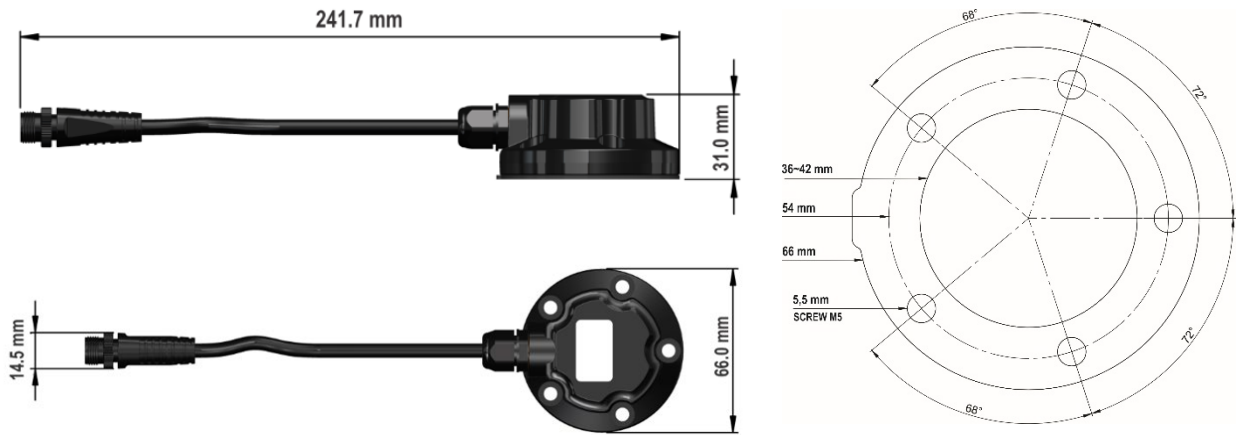

Figure 15

### 5.1.4.3 DIAMETER FOR LASER PASSAGE

The figure below shows the maximum and minimum hole diameters required to ensure laser passage, so as not to compromise the installation of the sensor in the tank or reservoir:

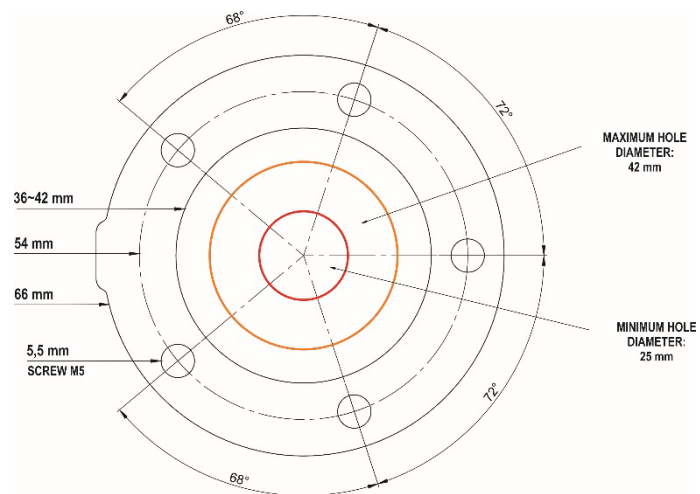

Figure 16

#### 5.1.4.4 5-HOLE TO 4-HOLE ADAPTER

The 5-hole to 4-hole adapter is an accessory for tanks that already have standard 4-hole drilling. The figure below shows the dimensions and drilling of the adapter for attaching the equipment:

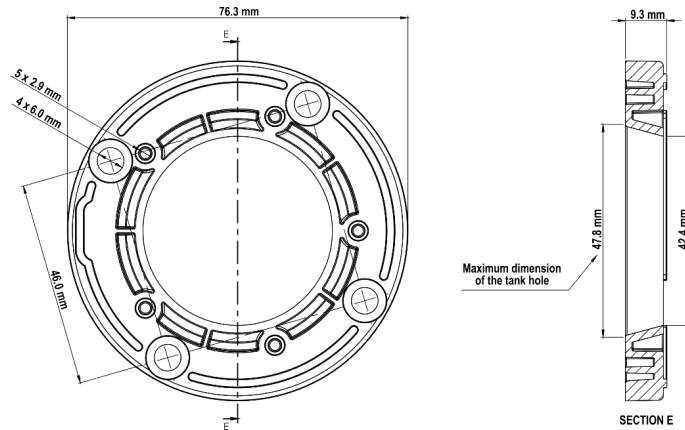

Figure 17

This adapter must be purchased separately:

- 4-hole adapter for **TL400** (Order code: 8802100300)

## 5.2 MECHANICAL INSTALLATION

To install the equipment, the following tools are required:

- 4.0 to 4.2 mm drill for the screws
- 20 to 40 mm hole saw for the sensor
- Pencil for marking the hole points

After that, you must follow the steps below:

1. **Perform the marking:** While the tank is empty, use the gasket to mark the hole points of the 5 screws and the sensor in the center of the ring. When using an adapter, mark the hole points of the 4 screws and the sensor in the center of the ring.

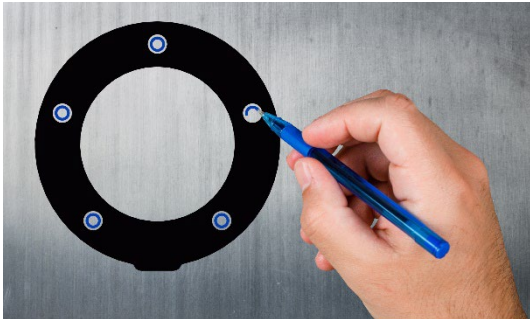

Figure 18

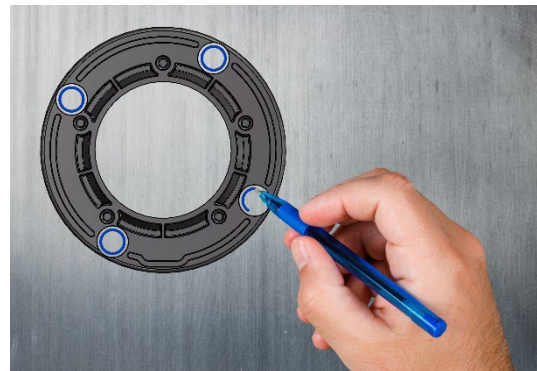

Figure 19

2. **Install:** Use a drill with the hole saw to drill the tank in the center, where the sensor will be installed. Then drill 4 mm holes at the marked positions. The gasket has a small cutout between the longer distance holes where the sensor output cable will be positioned.
3. **Make the connections:** After placing the equipment in the desired location, tighten the screws and then make the electrical connections (see [ELECTRICAL INSTALLATION](#) section).
4. **Configure:** Use **SigNow** to configure the equipment (see [SIGNOW: SOFTWARE AND APP](#) chapter).

### 5.2.1 TL400-V WITH AND WITHOUT ADAPTER

The figures below show versions of the equipment with and without the adapter (optional accessory):

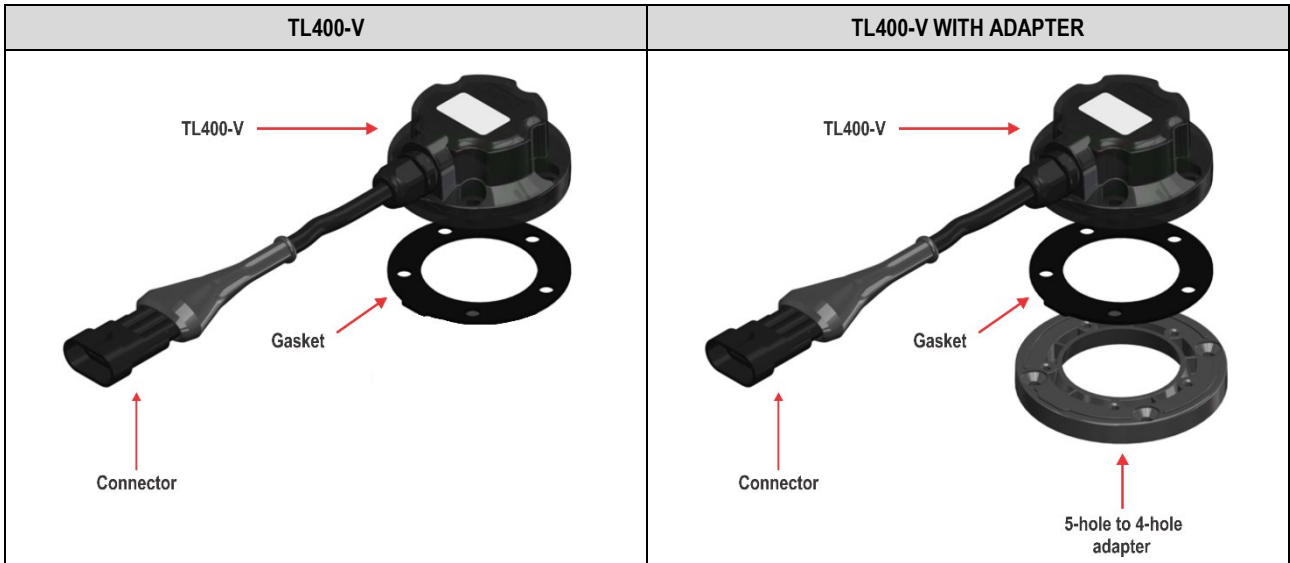

Figure 20

Figure 21

### 5.2.2 TL400-I WITH AND WITHOUT ADAPTER

The figures below show versions of the equipment with and without the adapter (optional accessory):

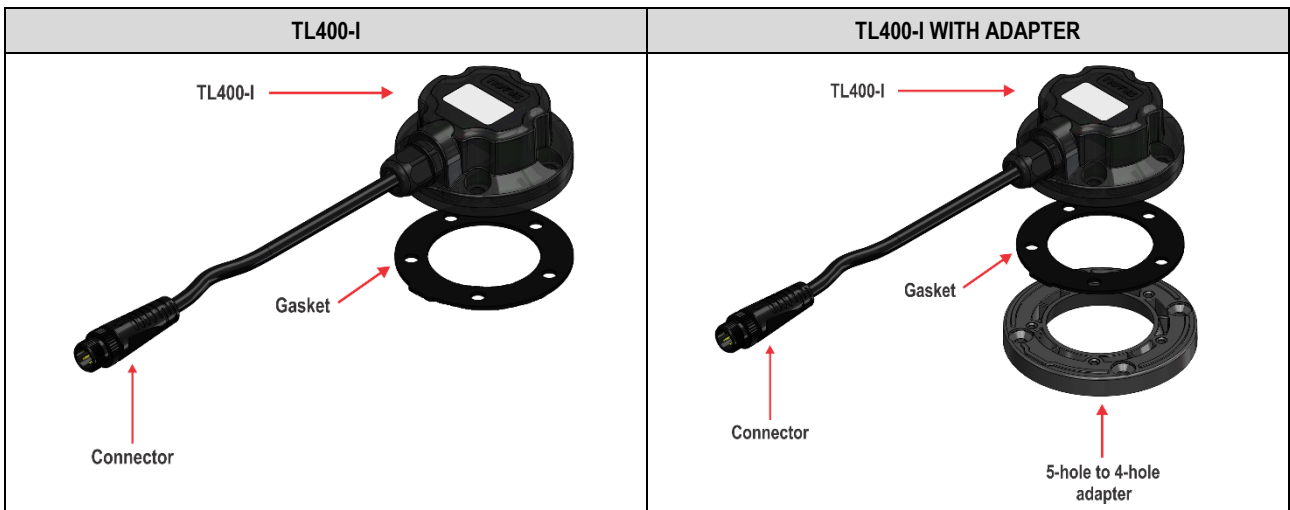

Figure 22

Figure 23

### 5.2.3 ADAPTER AND GASKET

To install the adapter and the gasket on any model, the correct position must be observed:

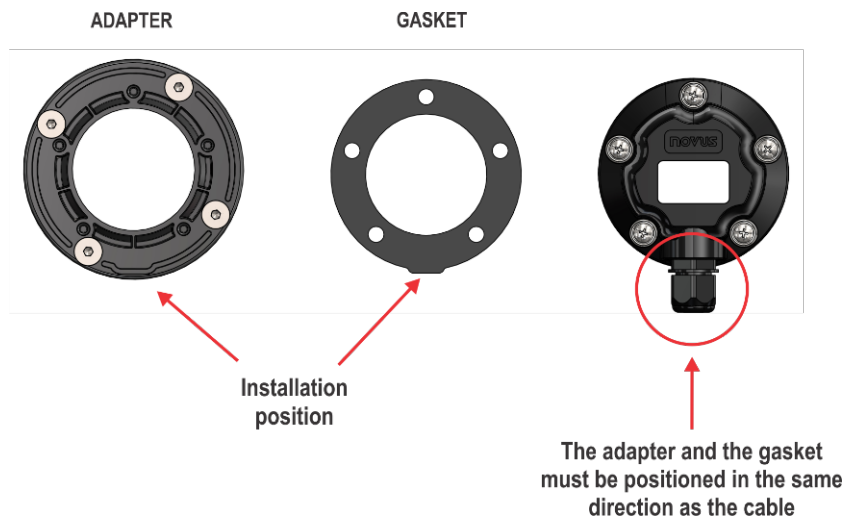

Figure 24

## 5.2.4 INSTALLATION EXAMPLES

The figures below show examples of how to position the equipment, according to the environment where it will be installed and considering the application:

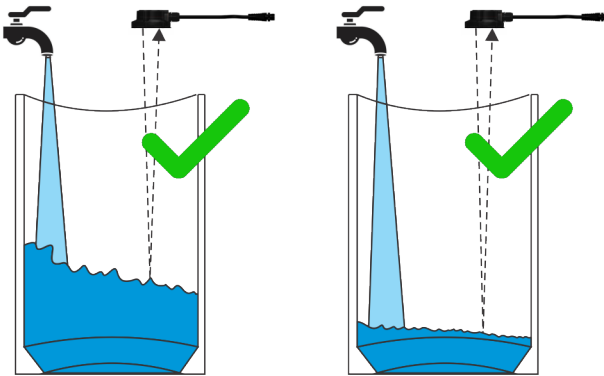

Figure 25

- Install the equipment so that the laser is perpendicular to the surface of the substance to be monitored.
- Ensure that the equipment is positioned away from the area where the liquid or solid will be poured into the tank or reservoir.

The figures below show examples of situations to be avoided during the installation process:

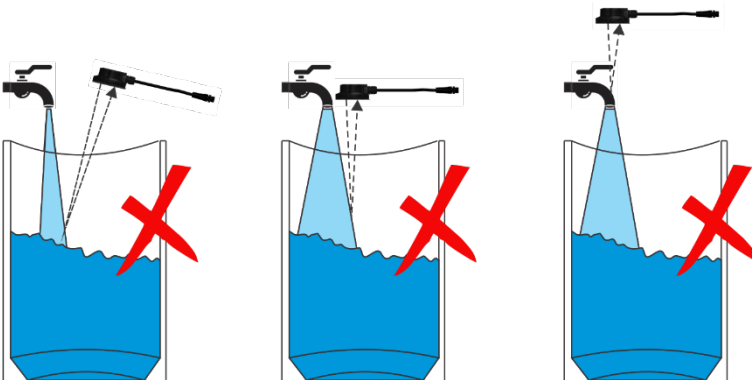

Figure 26

- **Do not** install the equipment sideways or with the laser pointing into the area where the liquid or solid will be poured into the reservoir.
- **Do not** install the equipment over a faucet, which will completely block the laser.

An improper application will block the equipment from measuring the area to be monitored as intended. **For this reason, you must always ensure that it is positioned perfectly perpendicular to the surface.**



TL400 is not recommended for applications in environments with direct sunlight. In such cases, measurement may be affected.



For the equipment to perform accurate measurements, it is essential that there are no barriers between the TL400 and the fluid or surface to be analyzed. TL400 cannot take measurements through a transparent surface. It must be applied directly to the material being measured.

## 6 RECOMMENDATIONS FOR USE AND APPLICATION

TL400 is designed to measure the level of solid or liquid surfaces, usually reservoirs or tanks of different shapes. The sensor takes thousands of measurements in one second and uses statistical algorithms to estimate the distance value. This measurement is based on the time of flight of the photons, which travel several paths from the emitter to the receiver.

Any surface can be detected, regardless of reflectivity or transparency, but some characteristics of the application can affect the reading.

### 6.1 SUNLIGHT

Direct sunlight on the sensor causes irreparable errors in the reading, making it unsuitable for this type of application.

Indirect light increases variability and decreases accuracy. In many cases, if the application does not require a fast response time, the **Dynamic Filter** can be used to circumvent the situation.

Errors occur due to the high presence of infrared in the sunlight spectrum. To solve this problem, the sensor should be protected from direct sunlight and, whenever possible, indirect sunlight should be minimized.

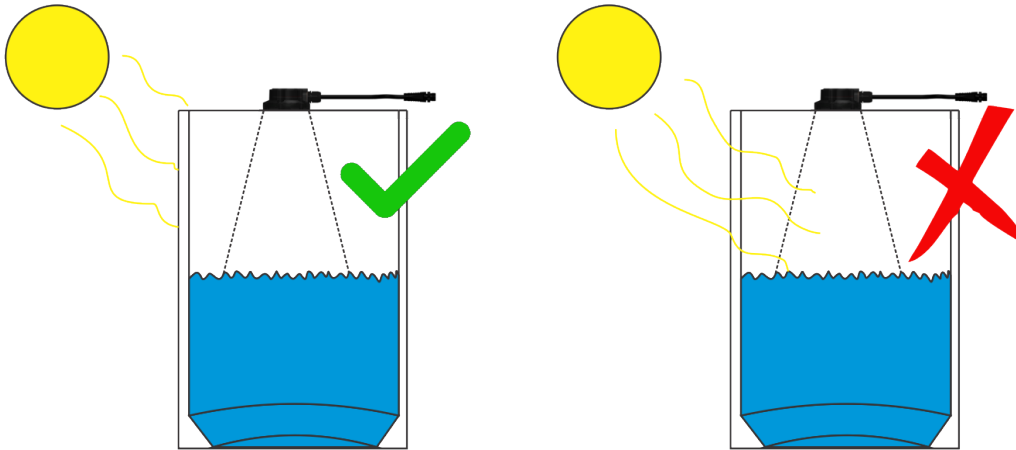

Figure 27

### 6.2 LOW LEVELS IN TRANSPARENT LIQUIDS

Transparent liquid surfaces reflect fewer photons than solid surfaces and reflection happens differently.

If the bottom of the tank has high reflectivity (if it is white, for example), it is possible that, as the level decreases (if the distance between the surface and the bottom is less than 10 centimeters), the bottom of the container will send out a much more intense signal than the surface of the water, thus generating intermittent measurements between the surface of the liquid and the bottom of the tank.

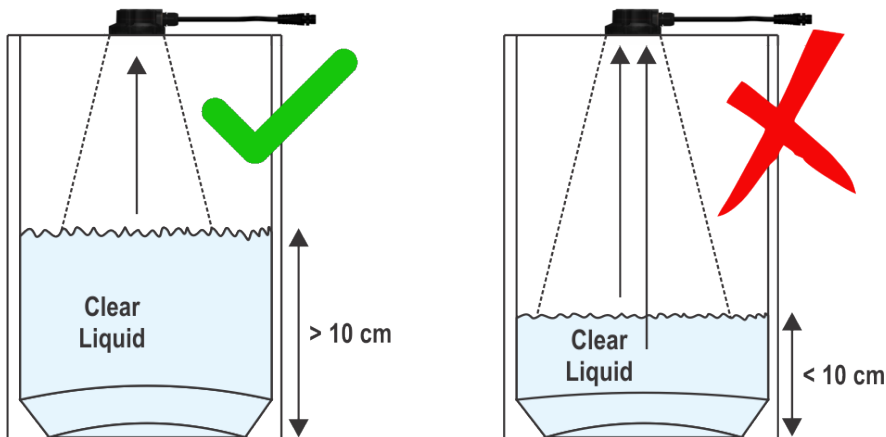

Figure 28

### 6.3 REFLECTIVE WALLS NEAR THE SENSOR

The figure below shows the angle of emission and reception of the infrared beam. The green range shows the angle of emission; the black range, the angle of reception.

Decreasing the aperture angle does not decrease the emission angle, only the reception angle. Reflective walls can therefore generate a non-linearity between the measured distance and the actual distance. In many cases, the problem can be corrected by creating a customized curve (see the [INPUT](#) subsection of the [SIGNOW: SOFTWARE AND APP](#) chapter).

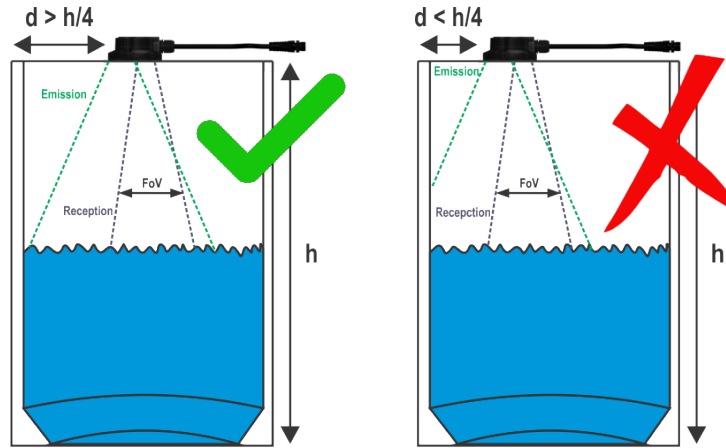

Figure 29

The table below shows examples of actual values, recommended for the distance described in this section:

TANK HEIGHT	DISTANCE BETWEEN THE SENSOR AND THE RECOMMENDED TANK WALL
100 cm	25 cm
200 cm	50 cm
300 cm	75 cm
400 cm	100 cm

Table 1

### 6.4 NARROW TANKS

For the same reason as described in the section above, using the sensor in a tank with a diameter that is small in relation to the height can lead to measurement failures. It is recommended to use a diameter equivalent to half the height. In a tank with a diameter of 50 cm, for example, it is recommended to use the sensor to measure up to 100 cm in height ( $h = d * 2$ ).

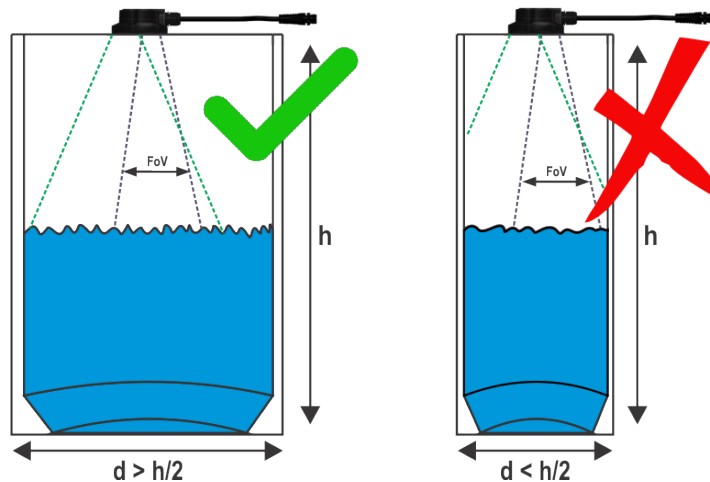

Figure 30

The table below shows examples of actual values, recommended for the distance described in this section:

TANK HEIGHT	TANK DIAMETER
100 cm	50 cm
200 cm	100 cm
300 cm	150 cm
400 cm	200 cm

Table 2

## 6.5 TANKS WITH SMOKE, DUST OR OPAQUE STEAM

Although the sensor “sees” in the infrared frequency, there is a high chance that, because it is a range of the spectrum very close to the visible light range, opaque dust or smoke will be detected by the sensor, leading to an incorrect measurement. It is not recommended to use the equipment in tanks with significant amounts of opaque smoke or dust.

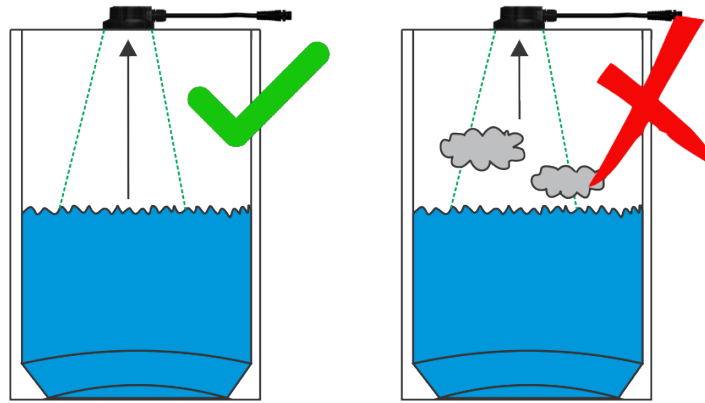

Figure 31

## 6.6 SMALL TANKS

The sensor is designed to operate at up to 4 m and can measure precisely from 5 cm from the face of the cover. However, measurements in tanks smaller than 10 cm and with transparent liquids may be less accurate. In this case, it is recommended to use spacers or even the 5-hole to 4-hole adapter<sup>2</sup> to move the sensor as far away as possible.

## 6.7 CHEMICAL COMPATIBILITY

TL400 uses highly robust polycarbonate, which guarantees greater mechanical and chemical resistance to various types of stress. Some materials, especially polycarbonate solvents, can damage the sensor lens, making it opaque and impossible to measure correctly.

The table below lists the materials that are known to be non-compatible:

MATERIAL	COMPATIBILITY
Toluene	Not Ok
Acetone	Not Ok
Methyl ethyl ketone	Not Ok
Dichloromethane	Not Ok

Table 3

## 6.8 INCLINED MEASURING SURFACE

On inclined surfaces, the emitted beam may escape from the receiving cone. This can lead to measurement errors. The sensor is recommended for applications with a maximum inclination of 11°. To solve the problem, the sensor should be installed so that this angle is less than 11°.

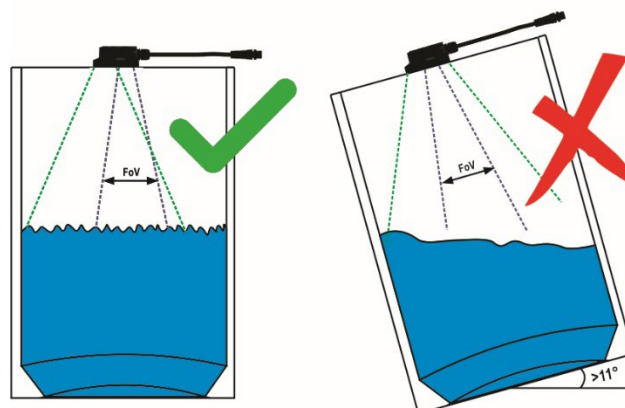

Figure 32

<sup>2</sup> This adapter must be purchased separately.

## 7 DEFINITIONS

This chapter presents definitions of terms to be considered throughout the manual.

### 7.1 TECHNICAL TERMINOLOGY

TL400 uses a few specific terms, such as ullage, level, distance, and height, which can be analyzed below:

- **Ullage:** Term used to describe the difference between the height of the tank and the surface of the liquid or solid.
- **Level:** Term used to describe the height of the liquid or solid when compared to the bottom of the tank.
- **Distance:** Term used to describe the height between the surface of the liquid or solid and TL400 (Offset = 0).
- **Tank height:** Term used to describe the total tank height.
- **Viewing angle:** Also known as Field of View (FoV), this parameter allows you to define the field of view for the sensor. To achieve the best sensor performance, it is recommended that it always be as large as possible. When using a sensor based on optical principles, it is important that the installation ensures that the bottom of the sensor is directed at the liquid surface in a fixed and perpendicular way, as shown in the figure below.
- **Installation Offset:** Term used to describe the difference between the height where TL400 was installed and the maximum tank height. The value must be inserted in the configured unit of measure. You must define an installation Offset when the maximum tank height and the height at which TL400 is installed are not the same.
- **Full tank (URV):** Term that corresponds to the height of the tank at which the analog output will show a maximum value.
- **Empty tank (LRV):** Term that corresponds to the height of the tank at which the analog output will show a minimum value.

The figure below shows an example of use:

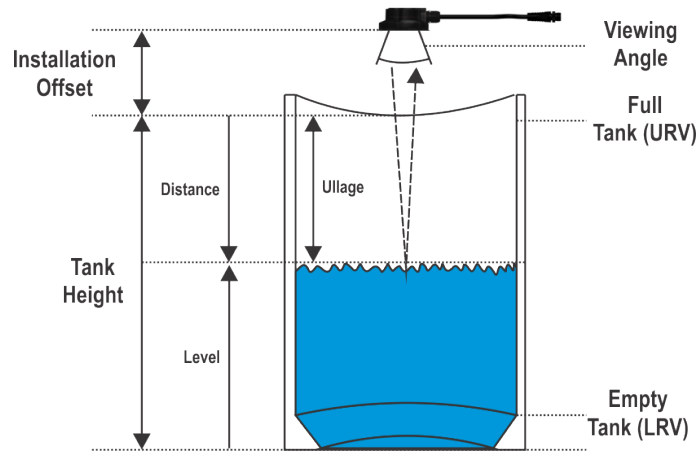

Figure 33

### 7.2 SOME TYPES OF TANKS

TL400 can be used with several types of tanks, as shown in the examples below:

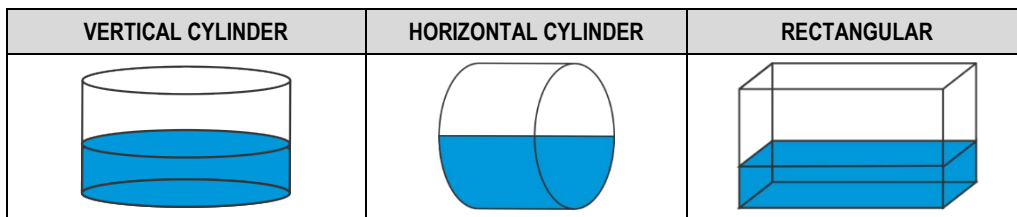

Figure 34

Figure 35

Figure 36

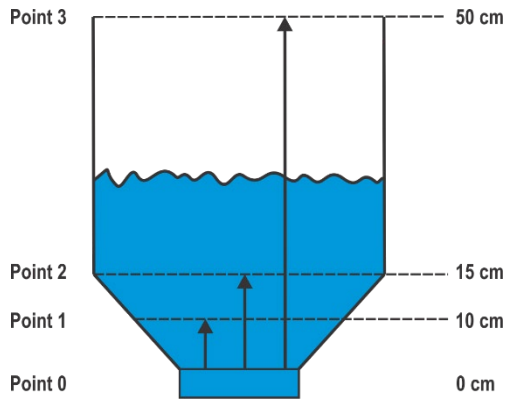

Figure 37

If the options do not fit the type of tank being used, **TL400** also allows you to create custom tanks. This feature is useful for tanks that are shaped with curves, rises, and other irregularities.

When you select this option, you will need to perform a linearization at specific points on the tank.

Up to 20 linearization points are allowed. The data configured in these parameters will always be in centimeters.

The custom curve can also be used to correct a possible non-linearity of the level sensor's measurement. To use the function for this purpose, you must go to the **Diagnostics** tab.

In the example below, the measurement inferred in the **Diagnostics** tab with an empty tank was 80 cm; with the tank at 50 %, it was 40 cm. Regardless of the actual distance measured by other means, simply insert the points as follows to obtain a custom curve:

When using the **Diagnostics** tab, you must take measurements of the desired curve and write down the distance values versus the desired percentage. Once you have all the values from 0 to 100 % with the desired number of points (with a maximum of 20 points), follow the path **Configuration > Advanced > Input > Tank Calibration** and insert the points as shown in the figure to the side. To delete a calibration point, simply drag it to the right.

After inserting all the points, follow the path **Menu > Send**.



**Before sending the configuration, it is suggested that you check the configured parameters. The parameters will be overwritten in the equipment.**

To check if the curve is in accordance with the set value, you can follow the path **Diagnostics > Advanced > Forcing** and force a distance, which will allow you to analyze if the analog output response is adequate.

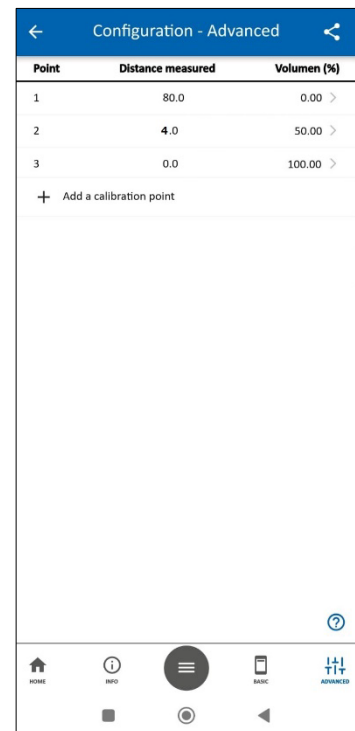

Figure 38

## 8 SIGNOW: SOFTWARE AND APP

Available for Windows PCs and Android and iOS smartphones, the **SigNow** software and app is the primary tool for configuring and diagnosing your **TL400**. You can connect to the equipment via Bluetooth Low Energy (BLE).

The **SigNow** desktop software and its user manual can be downloaded for free on **NOVUS'** website: [www.novusautomation.com](http://www.novusautomation.com).

The **SigNow** mobile app is available at no charge on the Google Play Store and the App Store. If your smartphone doesn't support BLE, runs Android earlier than version 9, or iOS earlier than version 12, the app will not be available for download.



This manual provides basic information on configuring your TL400. For more details on SigNow's features, please refer to the specific manual.

### 8.1 BLUETOOTH INTERACE

**TL400** has a Bluetooth Low Energy (BLE) interface, compatible with devices that have Bluetooth modules with version 4.0 or higher. The Bluetooth interface allows you to configure the equipment through **SigNow**.

### 8.2 SOFTWARE SIGNOW

Once initialized, **SigNow** will display the following screen and buttons:



Figure 39

**Configuration:** Allows to read the equipment to be configured by the software.

**Create Configuration:** Allows you to create a configuration for an equipment selected on the connection screen.

**Diagnostics:** Allows you to view diagnostic information about the operation of the connected equipment.

**Open Configuration:** Allows you to open a configuration file created via the **Create Configuration** section.

**Connections:** Allows you to manage and configure RS485 and Modbus-TCP connections.

**Firmware:** Allows you to update the firmware of the connected equipment.

**Settings:** Allows you to access the software management screen.

: Allows you to access the **SigNow** manual.

### 8.3 PAIRING TL400 WITH YOUR SOFTWARE

Once the software is installed and the **TL400** is powered on, click on the **Configuration** button and select the **BLE** pairing mode and the desired equipment:

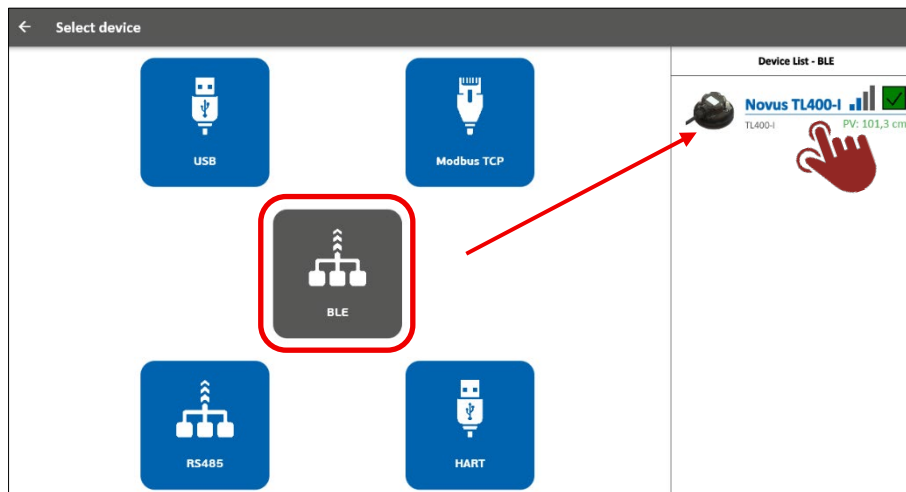

Figure 40

When selecting the desired equipment, if pairing is successful, the software will display the following options:

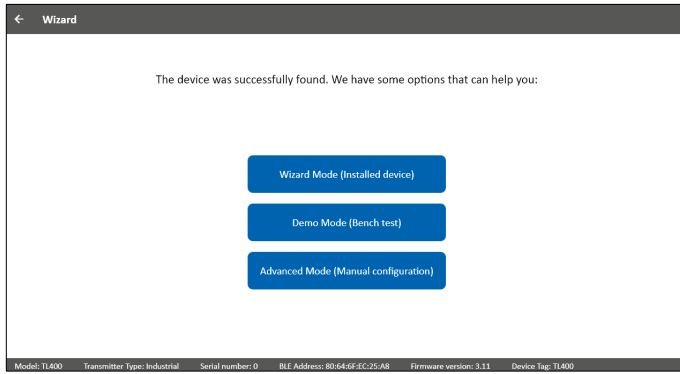

Figure 41

**Wizard Mode:** Wizard Mode allows you to find the best configuration for the type of tank or surface where the equipment will be installed.

**Demonstration Mode:** Demonstration Mode allows you to perform a basic test of the equipment's operation.

**Advanced Mode:** Advanced Mode allows you to manually configure all settings.

## 8.4 PAIRING TL400 WITH YOUR SMARTPHONE

Once the **SigNow** app has been installed, you must enable the Bluetooth interface of your smartphone to connect to the **TL400**. After that, simply open the app and follow the steps below:

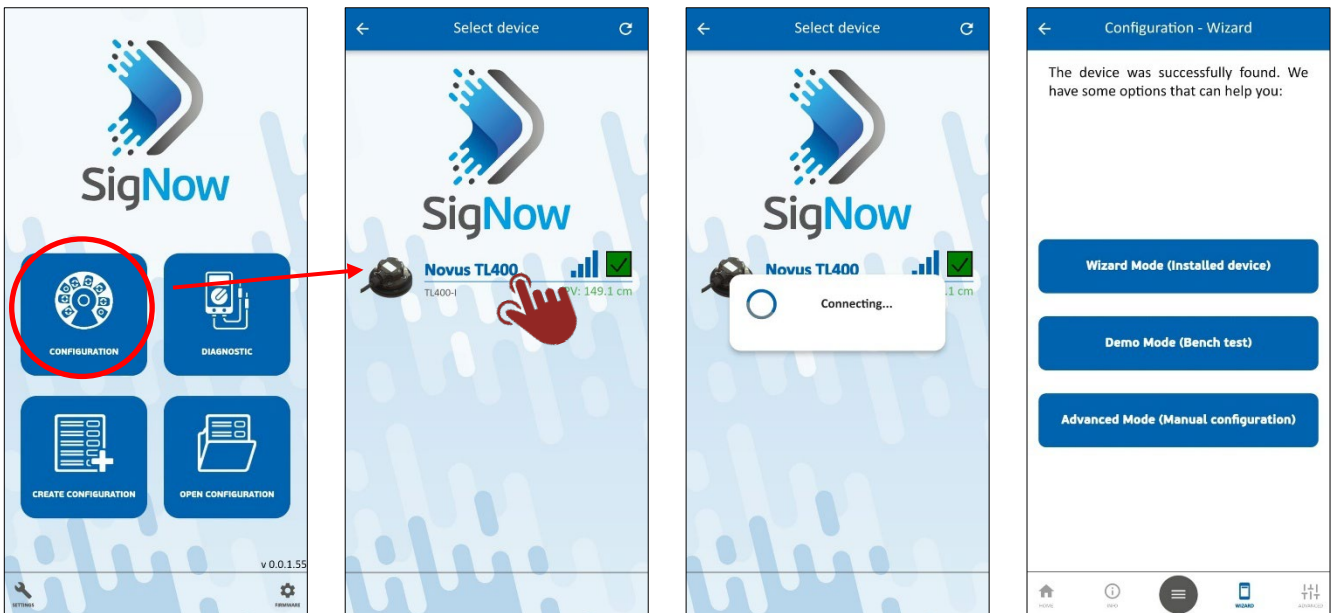

1. Click on the **Configuration** button.

2. Click on the desired equipment.

3. Wait for the connection process to finish.

4. That's it. Just select the configuration mode you want to use.

## 8.5 WIZARD MODE

By selecting the **Wizard Mode** option, the installation wizard will help you to configure the equipment according to the type of tank or surface where it will be installed:

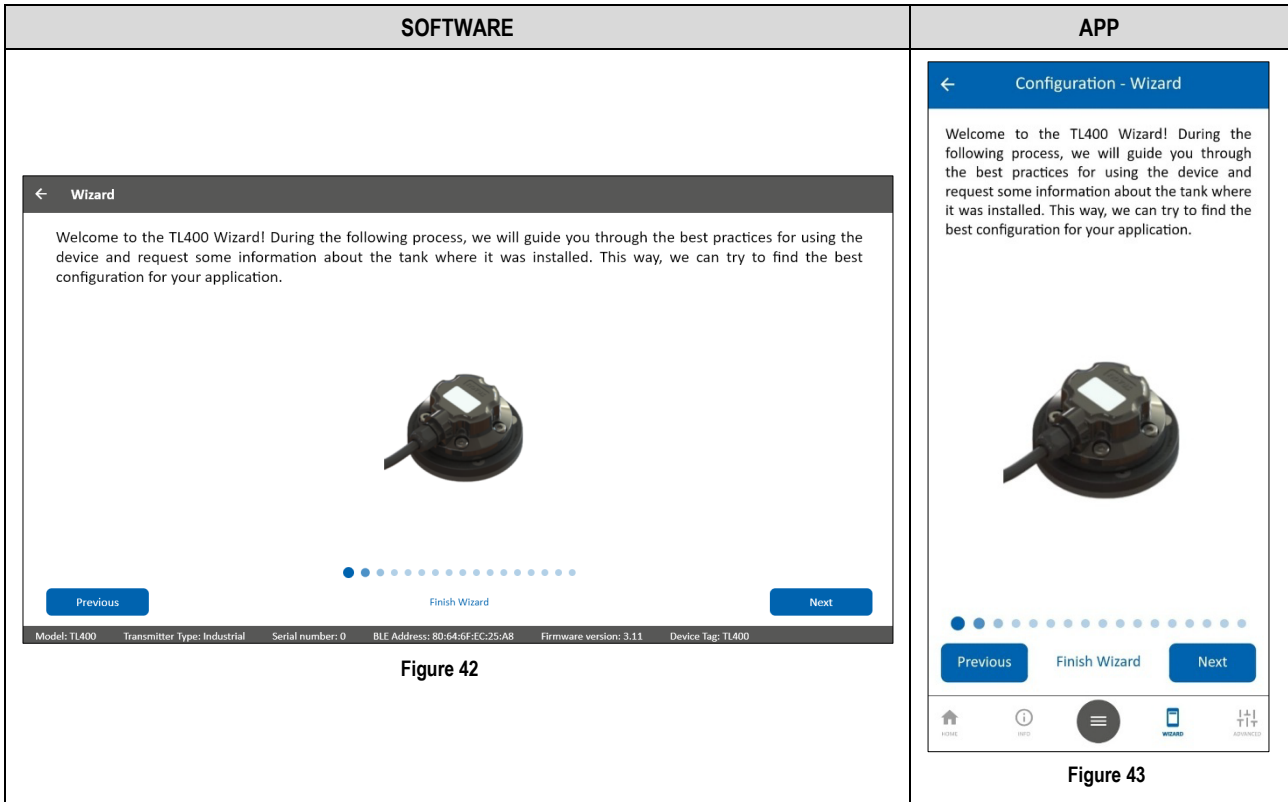

During this process, **SigNow** will collect information about the tank, sensor positioning, measurement type (Level, Volume, or Distance), installation Offset, and the speed at which the level varies within the tank, to help you to find the most suitable configuration for the application.

Once the information has been filled in, as presented by the **Wizard**, simply click the **Send Data** button to start the procedure, which, when finished, will display an analysis. If it matches the values of the tank used, it will be applied to the **TL400**:

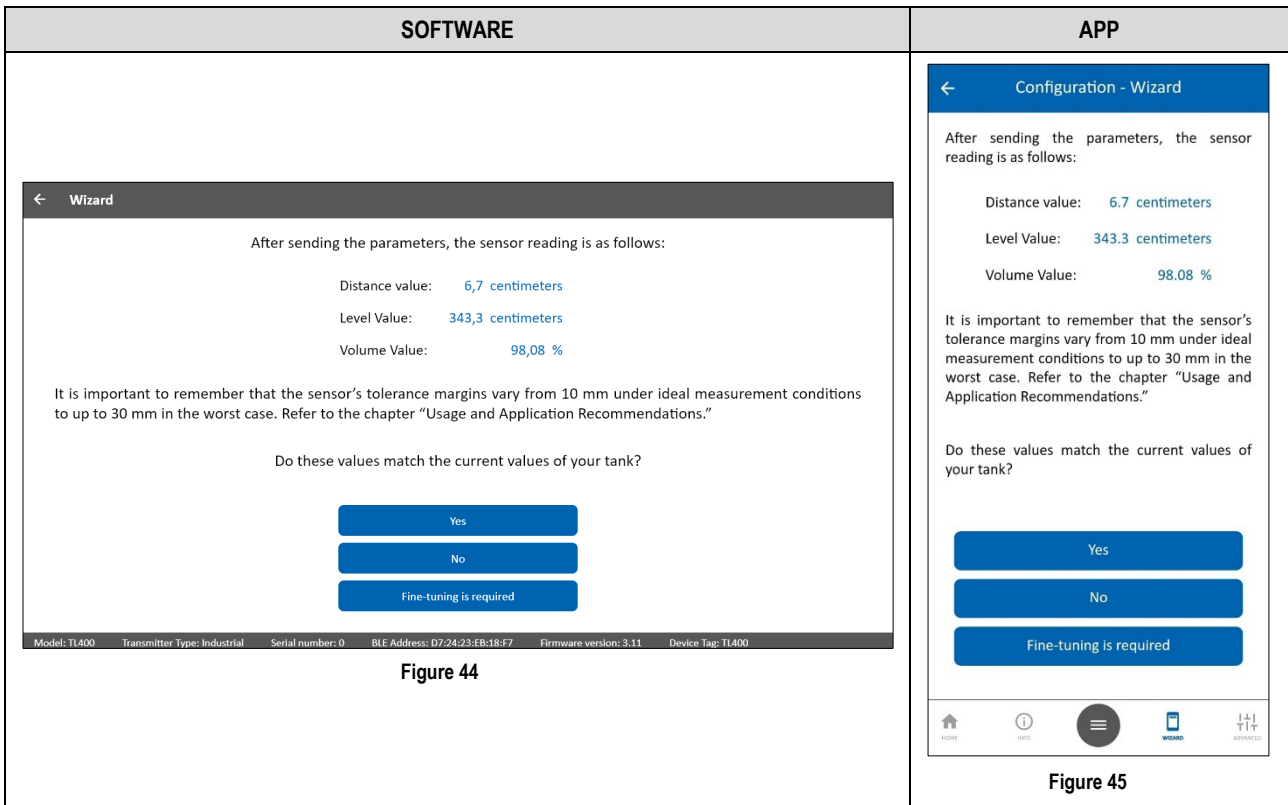

## 8.6 DEMONSTRATION MODE

**Demonstration Mode** allows you to test the equipment's operation:

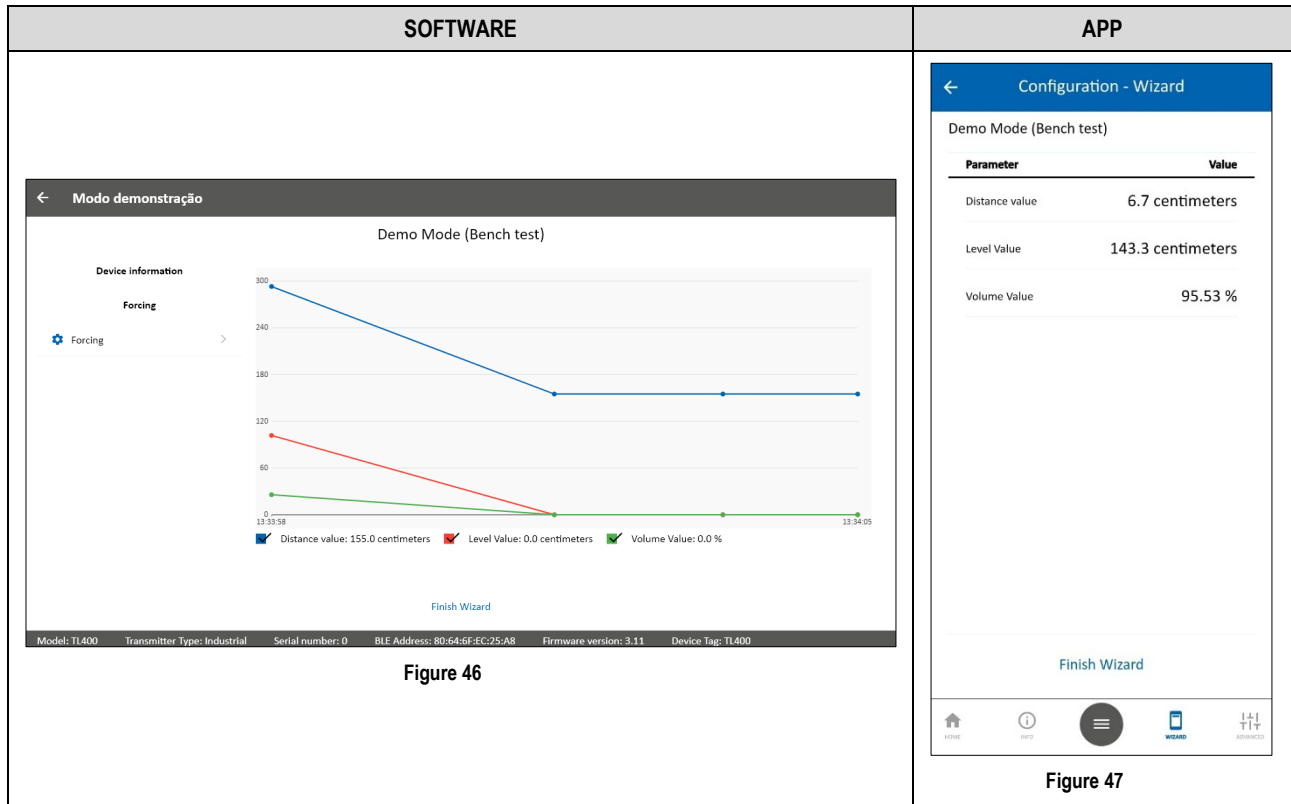

Figure 46

Figure 47

## 8.7 ADVANCED MODE

By selecting the **Advanced Mode** option, you can manually configure each parameter.

### 8.7.1 INFORMATION

Upon successfully completing the pairing process between smartphone and equipment, the app will display the configuration screens. The **Information** screen is the first one:

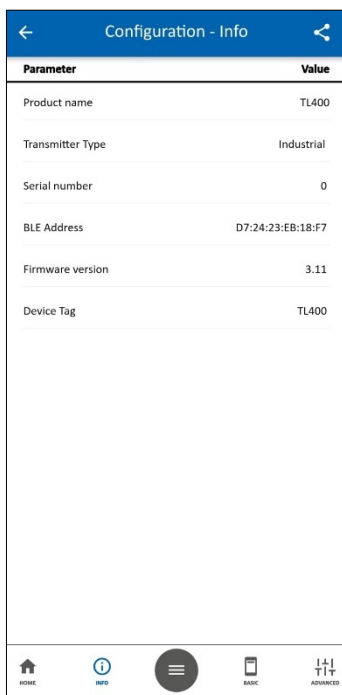

Figure 48

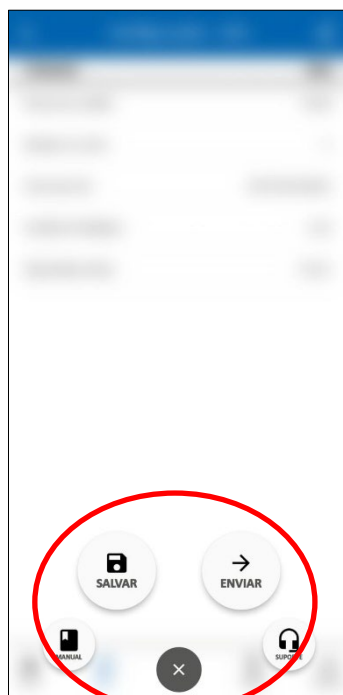

Figure 49

The **Info** section of the **Configuration** screen presents information such as serial number, firmware version, BLE address and equipment tag, which can be set in the **Device Tag** parameter of the **General** section.

None of this information is editable.

By clicking the **Home** button, you will be redirected to the home page.

By clicking the **Menu** button, **SigNow** will display a set of buttons, as shown in the figure opposite.

By clicking the **Manual** button, you will be redirected to the online manual of the equipment.

By clicking the **Support** button, you will be redirected to **NOVUS'** Technical Support page.

The **Send** button allows you to send the settings to the equipment.

The **Save** button allows you to save these configurations in a file with a .sigc extension, which can be used later by clicking the **Open Configuration** button on **SigNow**.

In the software, this information will be displayed at the bottom of the screen, in the **Configuration** section:

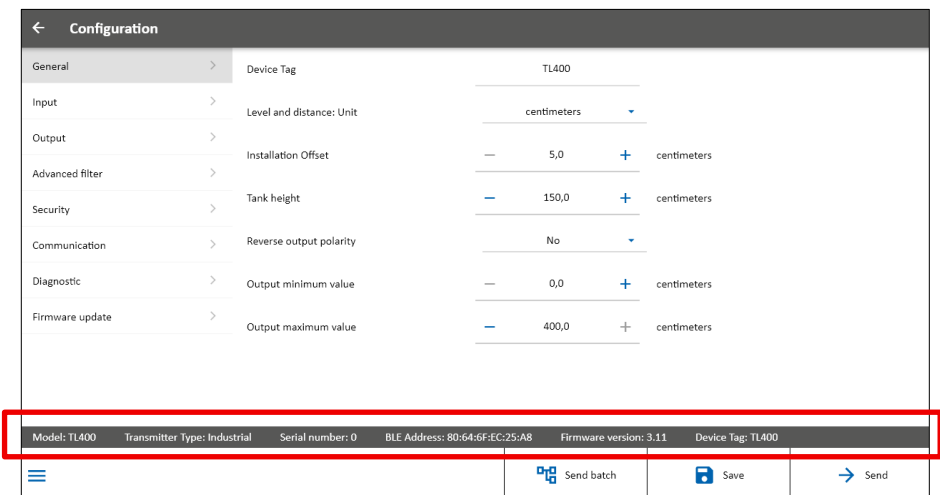

Figure 50

### 8.7.2 GENERAL CONFIGURATION

When you click on the **General** option, **SigNow** will display parameters related to the basic configuration of the equipment:

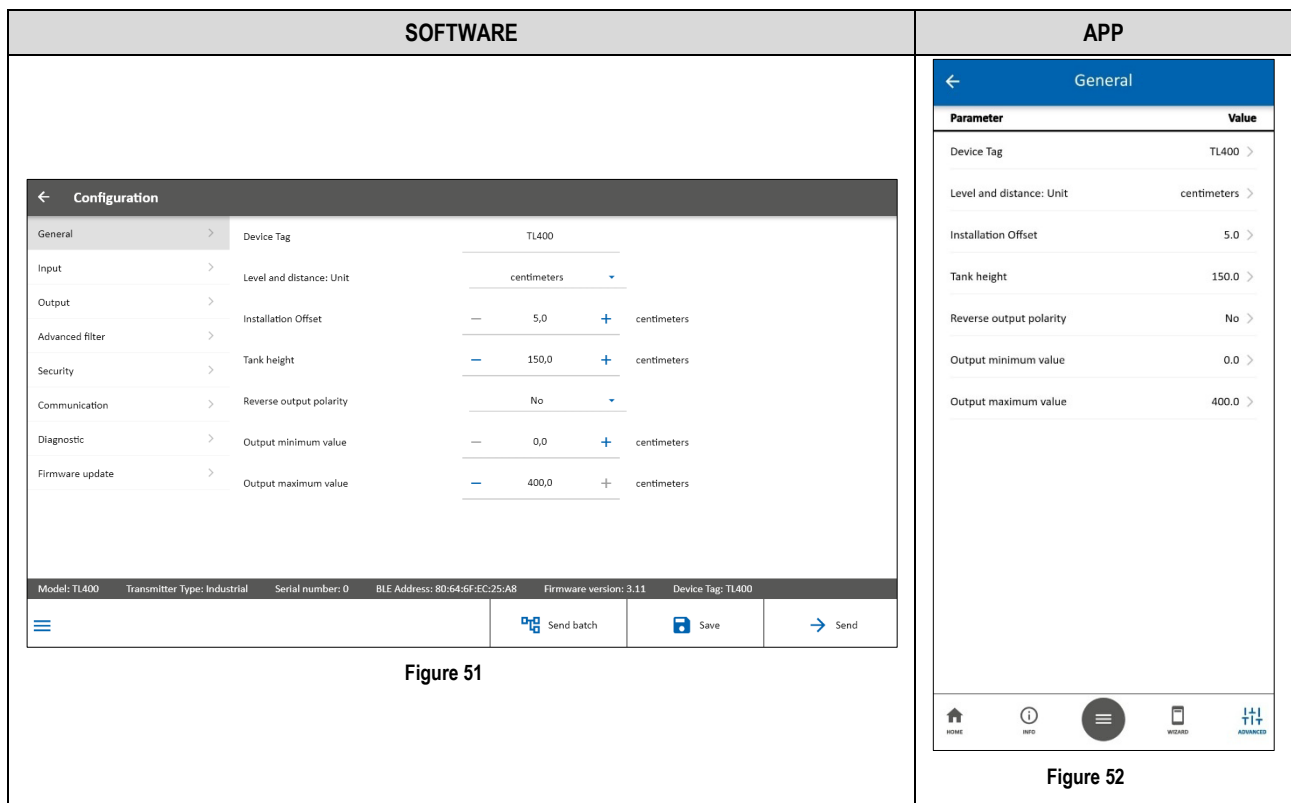

Figure 51

Figure 52

By default, the equipment is already configured with the magnitude «**Level**» (the magnitude can be changed in the **Input** subsection of the **Advanced** section, as will be shown later), which allows you to configure the following parameters:

- **Device Tag:** Allows you to define a tag with up to 20 characters for the equipment.
- **Level and distance: Unit:** Allows you to define the unit of measurement to be used.
- **Installation Offset:** Allows you to define the installation Offset.
- **Tank height:** Allows you to define the height of the tank to be used.
- **Reverse output polarity:** Allows you to invert the output polarity.
- **Output minimum value:** Allows you to define a minimum level value.
- **Output maximum value:** Allows you to define a maximum level value.

### 8.7.3 ADVANCED CONFIGURATION

When you click on the **Advanced** option, the app will display sections related to advanced configuration of the equipment:

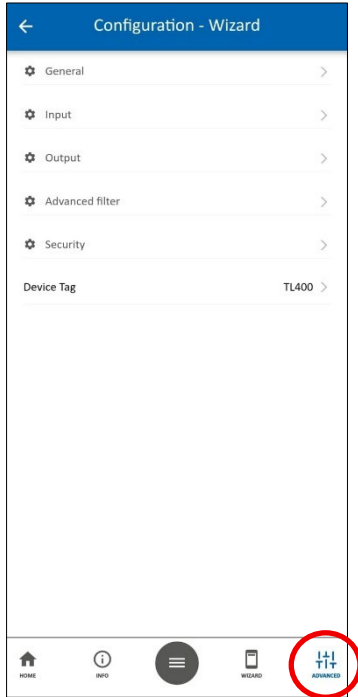

Figure 53

In this screen you can select the parameter group to be configured: **General**, **Input**, **Output**, **Advanced Filter**, or **Security**. You can also change the equipment tag (In the software, this parameter is in the [COMMUNICATION](#) tab).

The software does not have this division. All configuration tabs can be viewed on the left side of the software screen.

#### 8.7.3.1 INPUT

When you click on the **Input** option, **SigNow** will display parameters related to the input settings of the equipment:

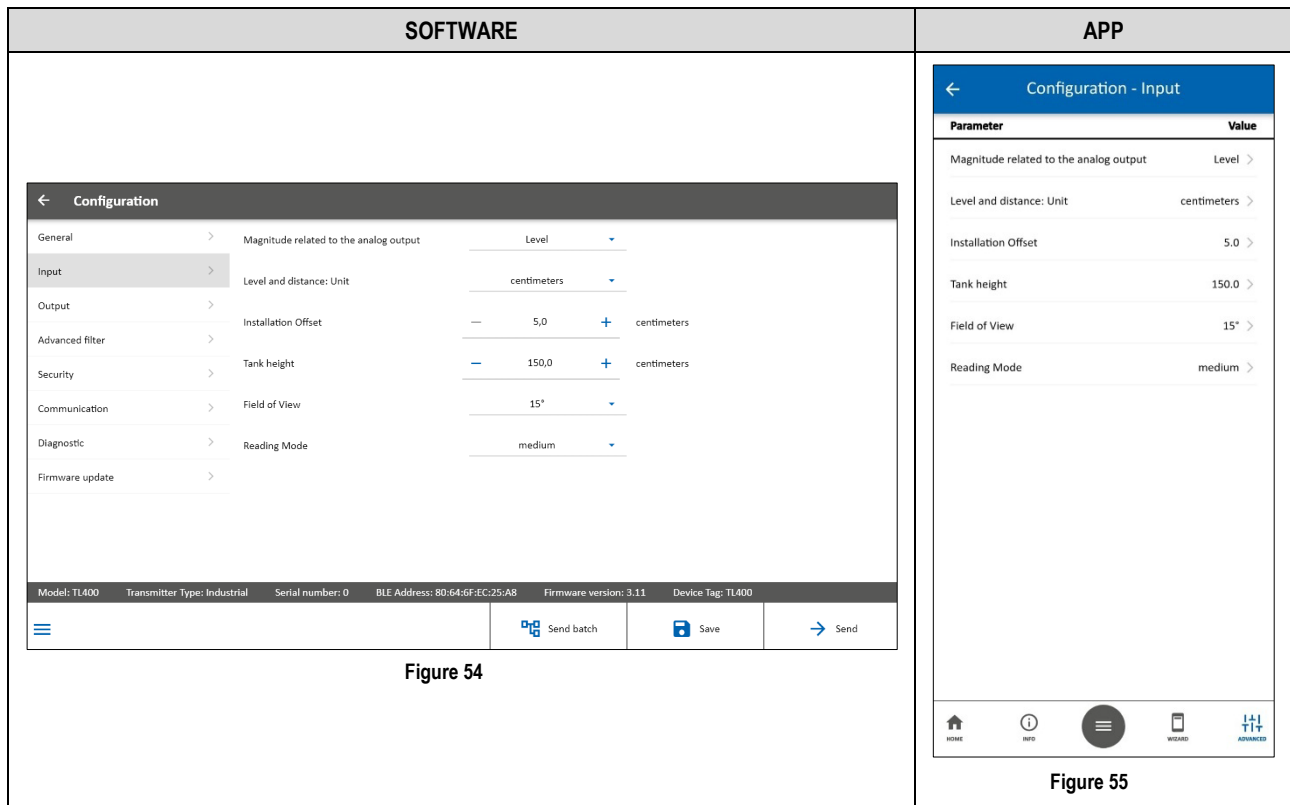

Figure 54

Figure 55

By default, the parameter «**Magnitude related to the analog output**» is set as «**Level**», which allows you to configure the following parameters:

- **Level and distance: Unit:** Allows you to define the unit of measurement to be used.
- **Installation Offset:** Allows you to define the installation Offset.
- **Tank height:** Allows you to define the height of the tank to be used.
- **Viewing angle:** Allows you to define the viewing angle of the equipment: 15°, 18°, 21°, 24°, or 27°.
- **Reading mode:** Allows you to set the measurement mode:

- **Short:** For distances shorter than 1 meter.
- **Medium:** For distances up to 3 meters.
- **Long:** For distances up to 4 meters. Long mode is the most recommended mode for most applications.

If the parameter «**Magnitude related to the analog output**» is set to «**Distance**», these same parameters will be displayed.

When configuring the parameter «**Magnitude related to the analog output**» with the «**Volume**» option, in addition to the parameters shown in the previous figure, you can also change the parameter «**Tank Type**» (Vertical cylinder, Horizontal cylinder, Rectangular, or Custom):

SOFTWARE	APP
	

Figure 56

Figure 57

According to the tank type selected, **SigNow** will present configurable parameters to determine the size and measurement of the tank to be used.

If none of the standard tank types suit your needs, you can select the «**Custom**» option.

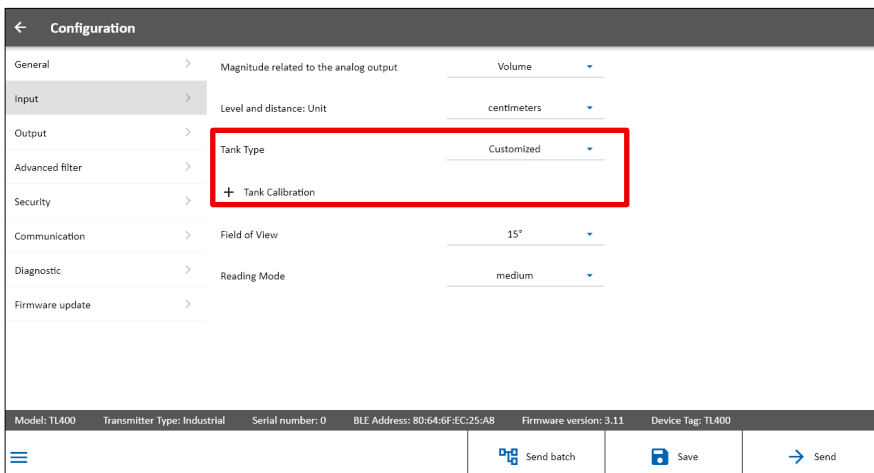
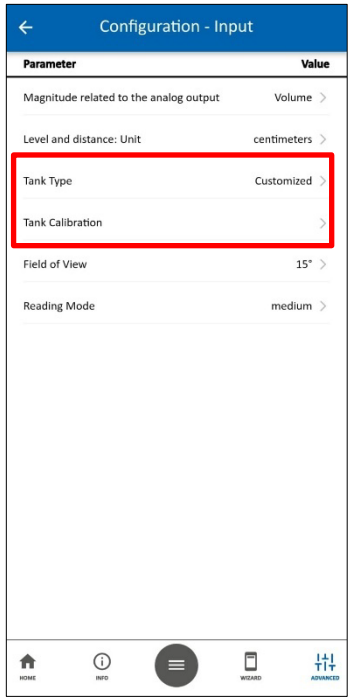
Here, you can add calibration points for the tank. You can set up to 20 linearization points by adding the desired values.

The custom tank type can be useful for tanks that are shaped with curves, rises, or other irregularities.

When configured to «**Custom**», the calibrated points should go from the greatest distance to the smallest distance (smallest volume to greatest volume), as shown in the example below:

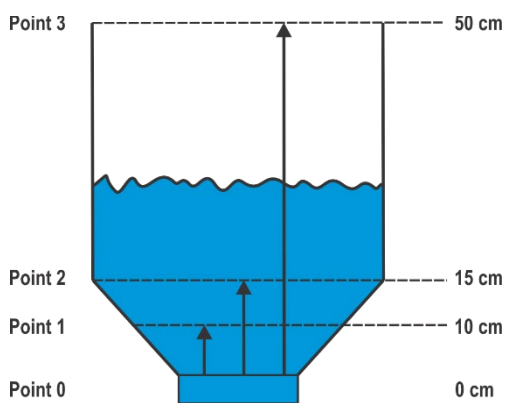

Figure 58

POINT	DISTANCE	VOLUME (%)
1	200	0
2	75	50
3	20	100

Table 4

### 8.7.3.2 OUTPUT

When you click on the **Output** option, **SigNow** will display parameters related to the output settings of the equipment:

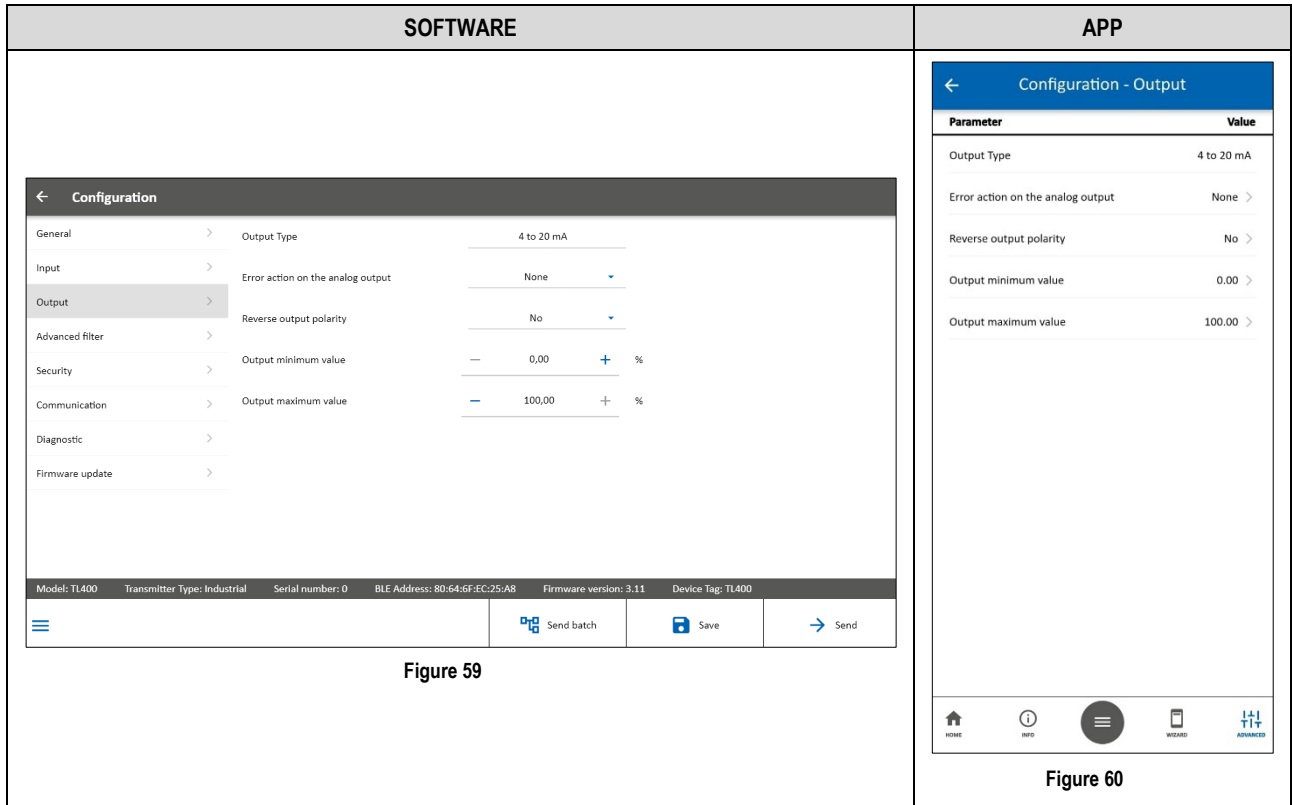

In a **TL400-V**, the parameter «**Error action on analog output**» allows you to configure the error action of an equipment with an output of 0.5–4.5 Vdc. This parameter has the following options:

- Low (0.5 Vdc)
- High (4.5 Vdc)
- None
- Low/High (0.5 Vdc / 4.5 Vdc)

In a **TL400-I**, the parameter «**Error action on analog output**» allows you to configure the error action of an equipment with 4-20 mA output. This parameter has the following options:

- Low (4 mA)
- High (20 mA)
- None
- Low/High (4 mA / 20 mA)

In addition, this section also allows you to set a minimum and maximum value for the output or reverse the polarity of the output.

### 8.7.3.3 ADVANCED FILTER

When you click on the **Advanced Filter** option, **SigNow** will display parameters related to the advanced filter settings for the equipment:

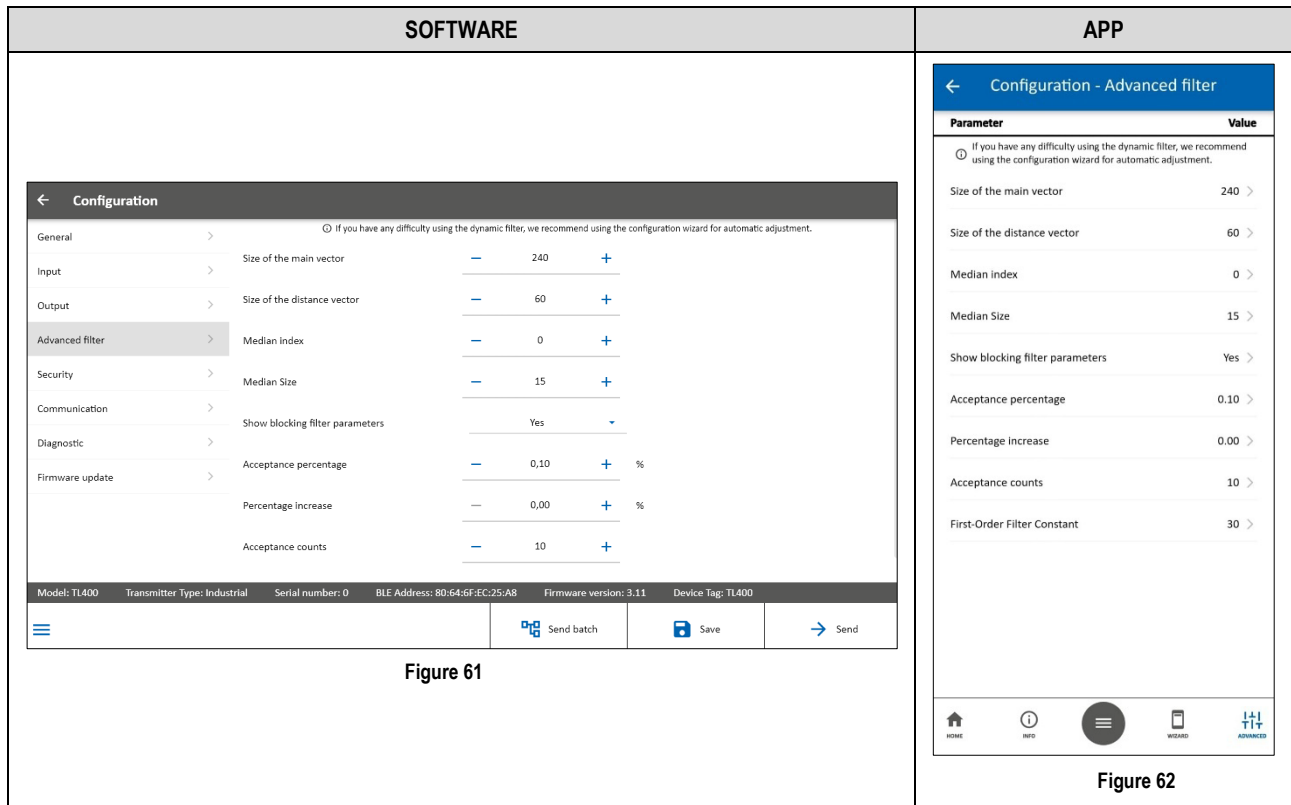

Figure 61

Figure 62

- **Size of the main vector:** Allows you to define the number of samples to be collected by the filter. If the user sets this parameter to 100, for example, **TL400** will only consider the first 100 values collected.
- **Size of the distance vector:** Allows you to select the best quality samples from among those collected by the filter (i.e., those with the least variation in values).
- **Median index:** Allows you to reorder the ideal samples, i.e., those already filtered by the «**Size of the distance vector**» parameter, now according to distance.
- **Median size:** Allows you to define the number of samples to be used based on the index configured in the «**Median index**» parameter. After selecting the best samples using the «**Size of the distance vector**» parameter, this value allows you to restrict the number of samples to be considered around the median index, further refining the statistical analysis.
- **Show Blocking Filter parameters:** Allows you to display the parameters relating to the Blocking Filter, which prevents values that are too discrepant from the previous value from being displayed in the output. By default, the Blocking Filter remains disabled.
  - **Acceptance percentage:** Allows you to define the maximum percentage of variation between the previous value and the value to be accepted by Blocking Filter. If the current value exceeds the percentage defined in this parameter, the Blocking Filter will ignore the discrepant value.
  - **Percentage increase:** Allows you to set the percentage of values to be incremented, according to the criteria, and each time a new value outside this percentage occurs. If there are fluctuations in values outside the percentage defined in this parameter, certain measures will no longer be accepted, and the acceptance rate will increase as the increment increases.
  - **Acceptance counts:** Allows you to set the maximum number of times that the Blocking Filter can reject data outside the standard defined in the parameter «**Acceptance percentage**». In other words, it will record the number of occurrences of blocking new measurements and, when it reaches the maximum configured value, it will start to accept these new values according to the percentage defined in the Acceptance percentage parameter.
 

This parameter complements the «**Percentage increase**» parameter. If the value configured in this parameter is reached, the Blocking Filter will start accepting the next values, even if they exceed the value configured in the «**Percentage increase**» parameter. This allows data to be collected even during sudden level changes.
  - **First-Order filter constant:** This parameter allows you to define the number of samples to be used from the index configured in the «**Median Index**» parameter. After the «**Size of the Distance Vector**» parameter has selected the best samples, this value allows the number of samples considered to be restricted around the median index, refining the statistical analysis.

The [ADVANCED FILTER](#) chapter provides more complex information on how this filter's parameters work, as well as examples and graphs.

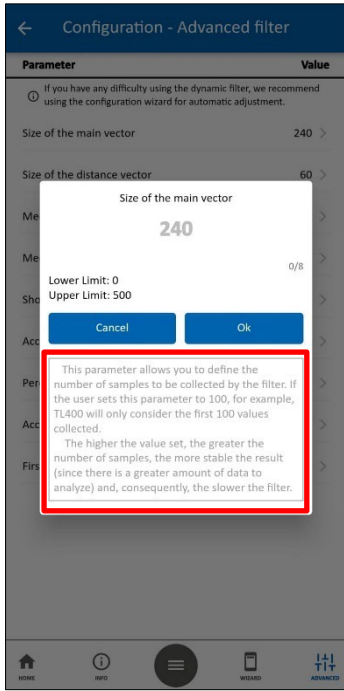

Figure 63

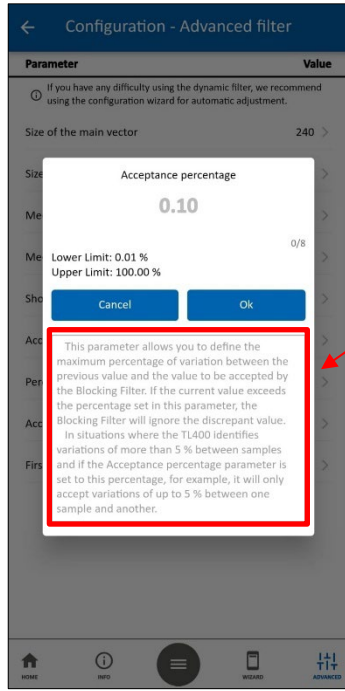



Figure 64

By clicking on a specific parameter to configure it on the app, as shown in the examples opposite, you can see explanations of how to use it. In the software, you can do the same by clicking on the icon , which appears when you move the mouse over the parameter name.

These explanations are also shown in detail in the [ADVANCED FILTER](#) chapter.

### 8.7.3.4 SECURITY

TL400 requires the configuration of an 8-digit numeric password. This feature prevents access by unauthorized users.

By clicking the **Security** option, **SigNow** will display parameters referring to the security settings of the equipment:

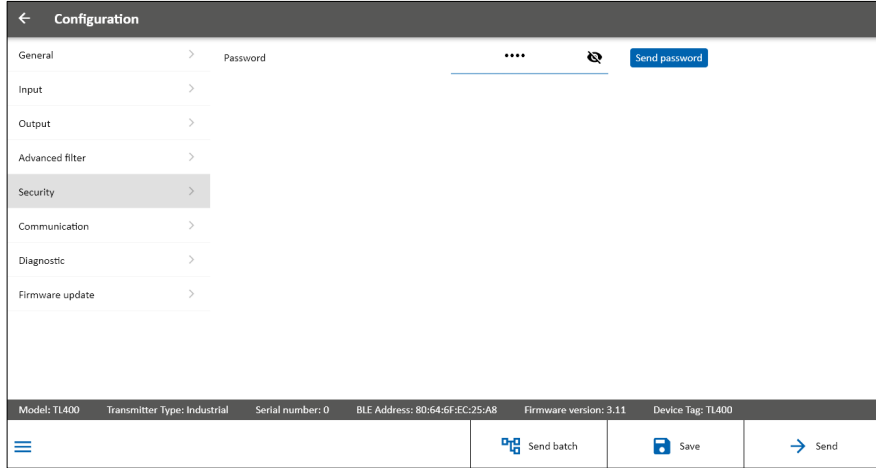
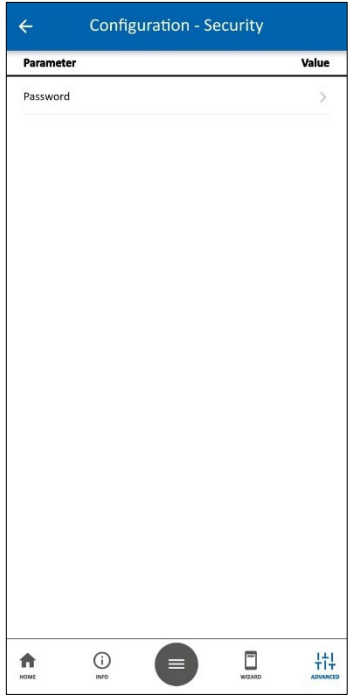
SOFTWARE	APP
	
<p>Figure 65</p>	<p>Figure 66</p>

## 8.7.4 COMMUNICATION

When you click on the **Communication** option, **SigNow** will allow you to configure a new Tag for the equipment:

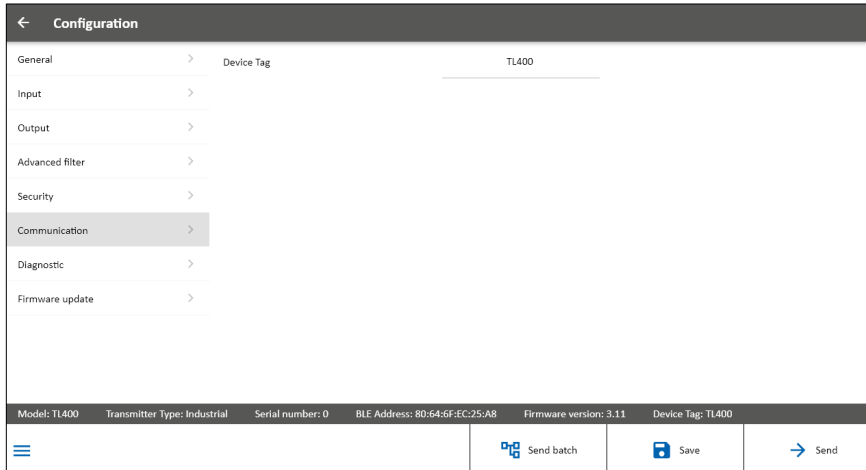

Figure 67

In the app, you can change the tag in the [ADVANCED CONFIGURATION](#) tab.

## 8.7.5

## 8.7.6 DIAGNOSTIC

When you click the **Diagnostic** button on the home screen and select the connection mode, the available equipment will be displayed:

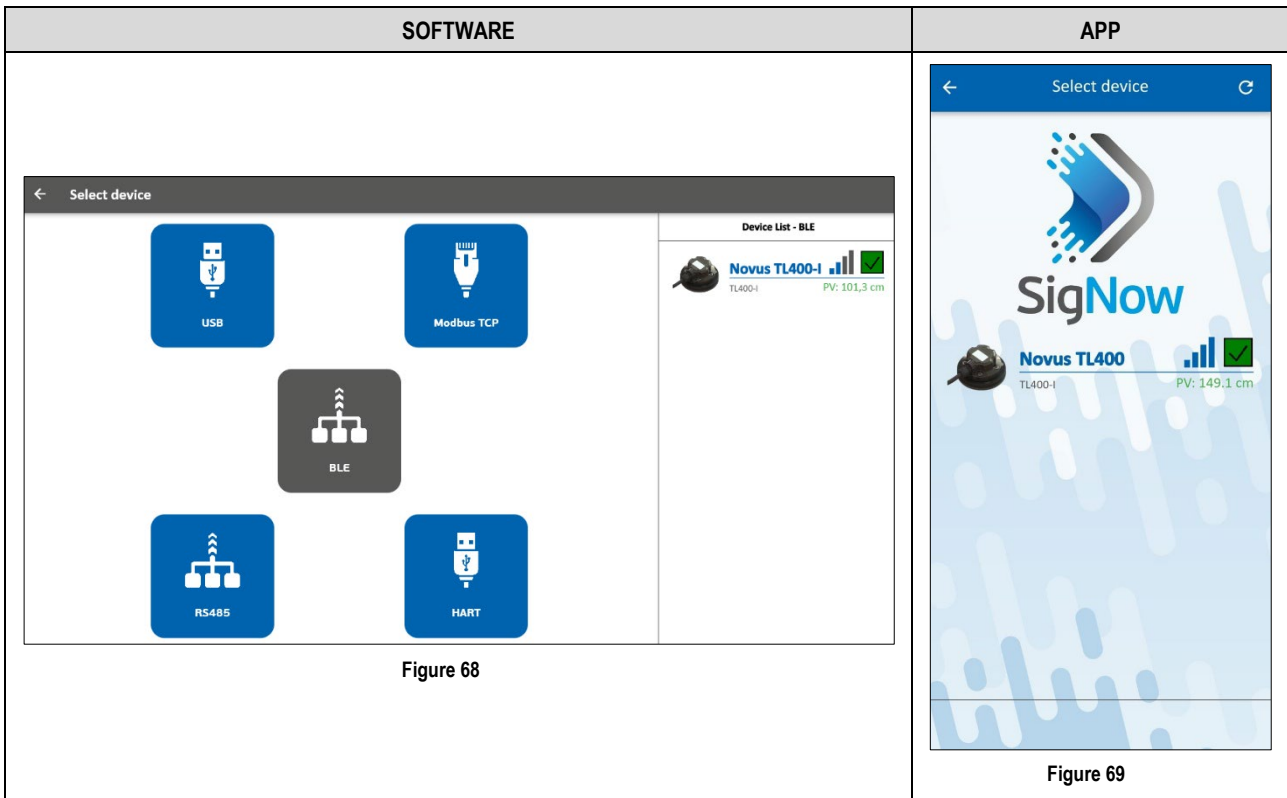





Figure 68

Figure 69

**TL400** is compatible with NAMUR (NE 107) and NAMUR43 (NE 43), standards that regulate analog output status signals and failure modes. In the case of this equipment, the error signal.

If **TL400** has a failure that compromises any of the sensor's main functions (either the sensor itself or the analog output), it will display the symbol . To correct this, check the equipment's configuration.

If **TL400** is out of specification in the analog output range or in the sensor measurement range, it will display the symbol .

If **TL400** has any forcing enabled, it will display the symbol .

If **TL400** has no failures, it will display the symbol .

These symbols only serve as indicators and do not prevent connection or diagnosis.





SYMBOL	DESCRIPTION
	Normal operation (Ok).
	Out of specification.
	Operation control (Check Function).
	Failure.

Table 5

Once the equipment is selected, the app will display information about its configuration and other data. None of these fields are editable. The software will also display a graph of the configured values:

SOFTWARE	APP
 <p>The screenshot shows a 'Diagnostic' screen with a left sidebar for 'Device information' (Product name: TL400, Serial number: 0, BLE Address: D7:24:23:EB:18:F7, Firmware version: 3.11, Device Tag: TL400) and 'Forcing' (Forcing: &gt;). The main area features a line graph with three data series: a red line at 350, a green line at 100, and a blue line at 0. The x-axis represents time from 13:40:36 to 13:40:57. A legend at the bottom indicates: Distance value: 6.6 centimeters (checked), Level Value: 343.3 centimeters (unchecked), and Volume Value: 98.08 % (checked).</p>	 <p>The screenshot shows the 'Diagnostic - Info' screen with a 'Logs' icon in the top right. A table lists parameters and their values: Product name (TL400), Serial number (0), BLE Address (D7:24:23:EB:18:F7), Firmware version (3.11), and Device Tag (TL400). The bottom navigation bar includes icons for SUPPORT, MANUAL, INFO, and ADVANCED.</p>

Figure 70

Figure 71

By clicking on the **Advanced** button, located in the lower right corner of the **Info** screen of the app, or by clicking on the **Forcing** button, located in the left corner of the software, you will have access to advanced diagnostic settings, which allow you to force values to evaluate the correct functioning of the equipment and test the settings applied to it:

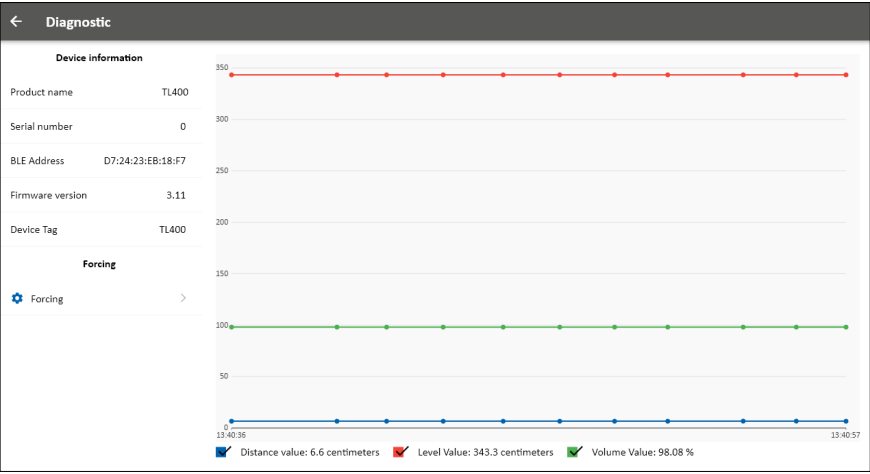
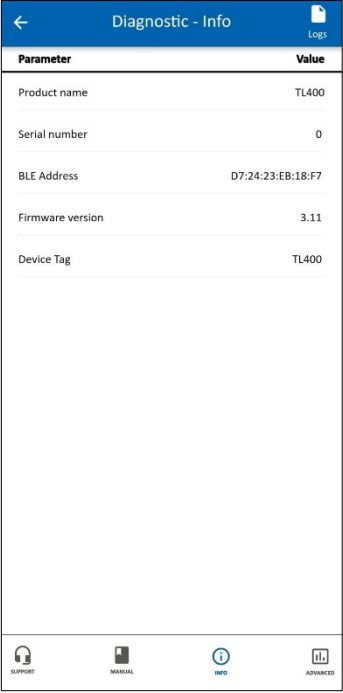
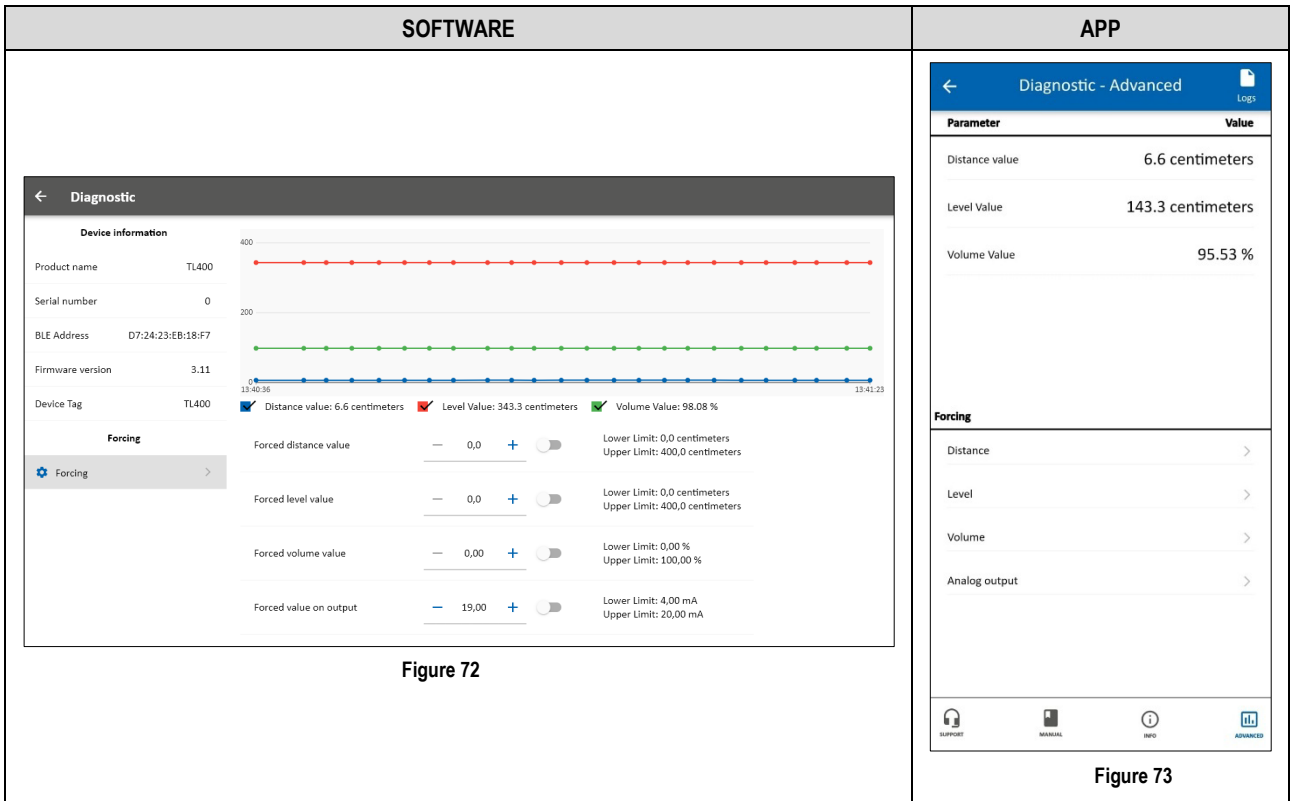

The **Advanced** section of the **Diagnostics** screen allows you to:

- 1) In the first part of the screen, you can see the current values of the equipment, according to the configuration.
- 2) In the second part of the screen, in the **Forcing** subsection, you can force specific values by selecting any of the 4 available options:
  - **Distance:** This parameter allows you to force a distance value for the equipment.
  - **Level:** This parameter allows you to force a level value for the equipment.
  - **Volume:** This parameter allows you to force a volume value for the equipment.
  - **Analog Output:** This parameter allows you to force the analog voltage output.

In either case, the output **must be enabled** to force test values.

When selecting one of the forcing options, you will be redirected to the appropriate screen, where you can set specific values for each parameter.

## 8.7.7 FIRMWARE UPDATE



Figure 74



Figure 75

To update the firmware through the app, click on the **Firmware** button at the bottom of the home screen.

Then, select the equipment to be updated and perform the pairing process.

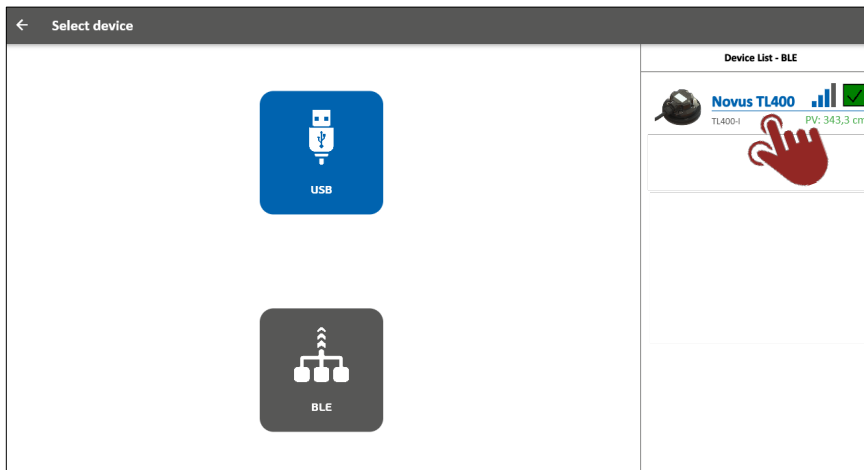

Figure 76

To update the firmware through the software, click on the **Firmware** button on the home screen.

Then, select the equipment to be updated and perform the pairing process.

By clicking on the **Search files** button, located in the left corner of the screen, you can search for previously downloaded files on your smartphone.

By clicking on the **Check files online** button, located in the right corner of the screen, you can check online for firmware files.

After that, simply select the file to be used by **SigNow** and perform the update process.



1. Devices with firmware version 3.2 or higher cannot be downgraded to lower versions.
2. Firmware updates via SigNow software are only available for devices with firmware versions 3.20 or higher. For devices with firmware versions lower than 3.20, the SigNow app must be used, which is available for Android and iOS.

## 9 ADVANCED FILTER

### 9.1 WHEN USE THE ADVANCED FILTER

The **Dynamic Filter** is an advanced feature designed to improve the stability and accuracy of sensor measurements, especially in high-performance applications. Based on advanced statistical techniques, this filter evaluates not only the instantaneous distance reading but also additional metrics for each sample, such as temporal variations and reliability indicators. By considering these factors, the filter smooths out spurious fluctuations, reduces noise, and delivers a more consistent distance estimate over time. The result is more reliable measurements, even in environments prone to interference or rapid changes.

The advanced filter can be configured within the **Advanced Configuration** section of **SigNow** (see [ADVANCED FILTER](#) section of [SIGNOW: SOFTWARE AND APP](#) chapter). By configuring certain parameters, this algorithm can significantly reduce measurement instabilities.

To better exemplify the need to use the advanced filter in certain situations, below is a real example of a measurement that doesn't need the filtering algorithm (left) and one in which it was necessary to use it (right). The raw measurement is blue; the filtered measurement is orange.

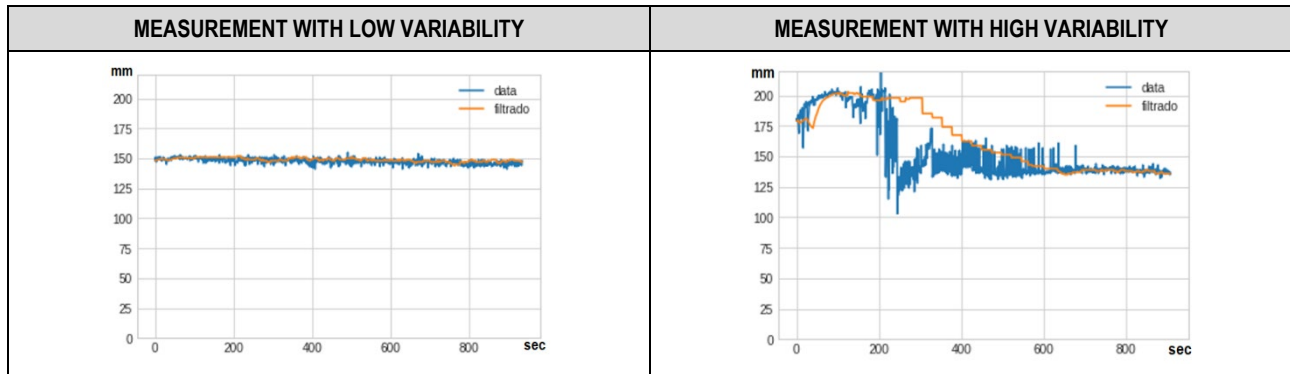

Figure 77

Figure 78

Internally, the algorithm is based on a sample sorting logic that acts according to the quality measure of the measurement itself and based on sorting according to the distance to collect the most stable measure of the group (median). Below is a description of the parameters and their influence on the measurement result.

### 9.2 A MORE DETAILED EXPLANATION OF THE ADVANCED FILTER PARAMETERS

The **Advanced Filter** of **SigNow** app is composed of 8 parameters. Below, it is possible to see a more complex explanation about their functioning.

#### 9.2.1 «SIZE OF THE MAIN VECTOR» PARAMETER

This parameter allows you to define the number of samples to be collected by the filter. If the user sets this parameter to 100, for example, **TL400** will only consider the first 100 values collected.

The higher the configured value, the greater the number of samples, the more stable the result (since there is a larger amount of data to analyze), and, consequently, the slower the filter. The response time of a median-based filter is typically half the number of samples divided by the sampling time (1 second for **TL400**), as shown below:

$$T_{resp} = \frac{No. samples}{2f} = \frac{MAIN VECTOR SIZE}{2}$$

#### 9.2.2 «SIZE OF THE DISTANCE VECTOR» PARAMETER

This parameter allows you to select the best quality samples from among those collected by the filter (i.e., those with the least variation in values).

More precisely, the vector will sort the samples from highest intensity to lowest intensity, creating an internal ordering invisible to the user. Thus, the first measurement in this list will always have the highest intensity, theoretically making it the most accurate within this range.

When performing an analysis from 1 up to the size configured in the «**Size of the main vector**» parameter, the measurements in this set will be those that survive after the other values have been discarded. If you put 100 in the «**Size of the main vector**» parameter and 20 in «**Size of the distance vector**», for example, the parameter will select the 20 best of these 100 samples, rejecting the other 80.

This parameter must be smaller than the one configured in the «**Size of the main vector**» parameter. The lower the value, the more selective the filter will be, and the fewer samples will be considered. The more unstable the behavior of the sensor, the "worse" samples should be discarded and therefore the smaller the «**Size of the distance vector**» should be.

When looking for greater stability and in conditions where response time is relevant, it is possible to increase the «**Size of the main vector**» and the «**Size of the distance vector**». By setting the «**Size of the main vector**» parameter to 400 and the «**Size of the distance vector**» parameter to 350, for example, an 80 cm measurement application will have an accuracy of 3 millimeters.

### 9.2.3 «MEDIAN INDEX» PARAMETER

This parameter allows you to reorder the ideal samples, i.e., those already filtered by the «**Size of the distance vector**» parameter, now according to distance. In this case, the «**Median index**» parameter will ignore the standard deviation, opting instead to analyze the median, which would be the central number of these values (the number of times that a value is repeated among the number of samples), either increasing or decreasing.

The «**Median index**» displays the position of the value in relation to the median containing the output value to be considered by the filter. The values that are most repeated among the samples collected are given the position 0 as an index. Samples with lower values receive negative indexers, while higher values receive positive indexers.

If the sensor is "missing too much" when collecting data, it is possible to reduce this difference by selecting a smaller position, using a «**Median index**» value that is less than 0.

The figure below exemplifies the position of the median, according to symmetrical situations (ideal situation not in line with reality), distortion to the right (negative indexers) and to the left (positive indexers):

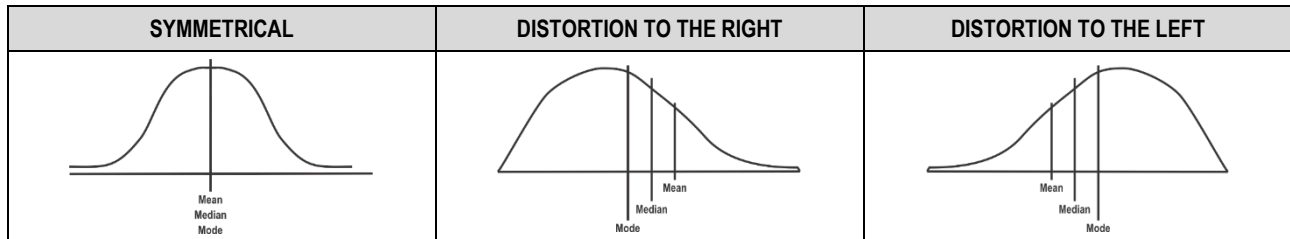

Figure 79

Figure 80

Figure 81

### 9.2.4 «MEDIAM SIZE» PARAMETER

This parameter allows you to define the number of samples used centrally around the index configured in the «**Median Index**» parameter. After the «**Size of the Distance Vector**» parameter selects the best samples, this value restricts how many of those samples (centered on the median index) will be considered, refining the statistical analysis.

The main advantage of this feature is sensitivity control in environments with high dynamic variability. In applications with strong agitation, such as tanks with rapidly moving liquid, it is recommended to reduce the value configured in this parameter to limit the impact of widely dispersed samples, resulting in a more responsive output that reflects the true level. In situations where measurements are taken over stable and predictable surfaces, increasing this parameter provides greater robustness and stability in the sensor output.

This parameter must always be set to a value less than or equal to the one configured in the «**Size of the Distance Vector**» parameter, as it acts as a centralized subset within that vector.

### 9.2.5 «ACCEPTANCE PERCENTAGE» PARAMETER

This parameter allows you to define the maximum percentage of variation between the previous value and the value to be accepted by the Blocking Filter parameter. If the current value exceeds the percentage set in this parameter, the Blocking Filter will ignore the discrepant value.

In situations where the TL400 identifies variations of more than 5 % between samples and if the «**Acceptance percentage**» parameter is set to this percentage, for example, it will only accept variations of up to 5 % between one sample and another.

**This parameter will only be displayed if the «Show Blocking Filter Parameters» parameter has been set to «Yes».**

**Use of the Blocking Filter functions is recommended for advanced users only.**

### 9.2.6 «PERCENTAGE INCREASE» PARAMETER

This parameter allows you to set the percentage of values to be incremented, according to the criterion and each time a new value outside this percentage occurs. If values fluctuate outside the percentage defined in «**Percentage increase**», for example, certain measures will no longer be accepted, and the acceptance rate will be increased by the increment.

Whenever a new measure fails to enter, the acceptance criterion is increased, increasing the chance that the next sample will be accepted.

**This parameter will only be displayed if the «Show Blocking Filter Parameters» parameter has been set to «Yes».**

**Use of the Blocking Filter functions is recommended for advanced users only.**

### 9.2.7 «ACCEPTANCE COUNTS» PARAMETER

This parameter allows you to establish the maximum number of times the Blocking Filter can reject data outside the range defined by the «**Acceptance Percentage**» parameter. In other words, it will count the occurrences of new measurement blocks and, upon reaching the configured maximum, will start accepting these new values at the percentage defined in «**Acceptance Percentage**».

The «**Acceptance counts**» parameter is complementary to the «**Percentage increase**» parameter. If the value set in «**Acceptance counts**» is reached, the blocking filter will accept the next values, even if they exceed the value set in the «**Percentage increase**» parameter. This allows data to be collected even during sudden changes in level.

When filling the tank quickly, for example, this parameter prevents the **TL400** from taking too long to identify changes in the tank level, since it will start accepting new samples after a sudden variation has occurred repeatedly and has reached the value set in this parameter:

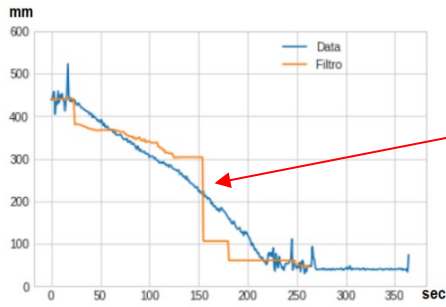

The moment when the **TL400** identified the change and, because of the excessive variation, began to accept the new samples.

Figure 82

This parameter will only be displayed if the «Show Blocking Filter Parameters» parameter has been set to «Yes». Use of the Blocking Filter functions is recommended for advanced users only.

### 9.2.8 «FIRST-ORDER CONSTANT» PARAMETER

This parameter allows to reduce oscillations or data spikes in the analog output. When the actual distance changes, it will take a time proportional to the value configured in this parameter to reach the new real distance. Essentially, it is a first-order filter applied to the Blocking Filter's output, smoothing the signal.

This parameter will only be displayed if the «Show Blocking Filter Parameters» parameter has been set to «Yes». Use of the Blocking Filter functions is recommended for advanced users only.

## 10 USAGE EXAMPLES

### 10.1 EXAMPLE 1: 3-METER HIGH AND 2-METER WIDE WATER TANK

In one application, the user intends to apply the sensor to measure a tank in a water tank with a tank height of 3 meters, the maximum level being 2.8 meters and with the bottom of the tank as the minimum level. It is also expected to get the current measurement proportional to the level, i.e. 20 mA at the maximum level (minimum distance) and 4 mA at the minimum level (maximum distance).

Here is an example of parameter configuration for this application:

- **Magnitude related to the analog output:** Level
- **Unit:** cm
- **Tank height:** 300 cm
- **Offset:** 0 cm
- **Filter type:** Static
- **Filter time constant in seconds:** 20
- **Angle of view:** 27°
- **Reading mode:** Long
- **Error action on analog output:** None
- **Invert output polarity:** No
- **Value for minimum output:** 0
- **Value for maximum output:** 280



Figure 83

### 10.2 EXAMPLE 2: 80 CM OIL TANK

When performing the diagnosis of the measurements that fill the tank of an oil tank with 80 cm high and 10 cm wide, it was verified that, although proportional to the level, the informed measurement did not match the real value. In this case, as shown in the information below, the user intends to correct the sensor reading with a 5-point curve:

PERCENTAGE OF VOLUME FILLED (PERCENT)	DISTANCE MEASURED ON DIAGNOSTIC TAB (CM)	REAL DISTANCE (CM)
0 % - Empty tank	100	80
25 %	85	60
50 %	50	40
75 %	25	20
100 %	10	0

Table 6

In this case, you must insert the points through the following path: **Configuration > Advanced > Input > Tank Calibration**, as shown in Figures 36 and 37. Then, in **Diagnostic > Advanced**, you can check the volume according to the distance, depending on the configured calibration. When using the custom curve, the tank height value will be ignored for the volume calculation.

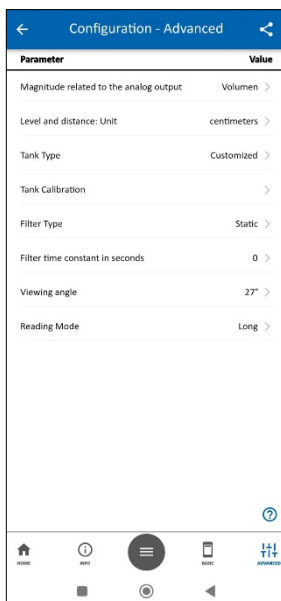

Figure 84

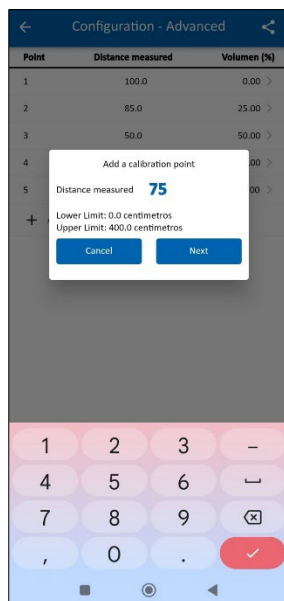

Figure 85

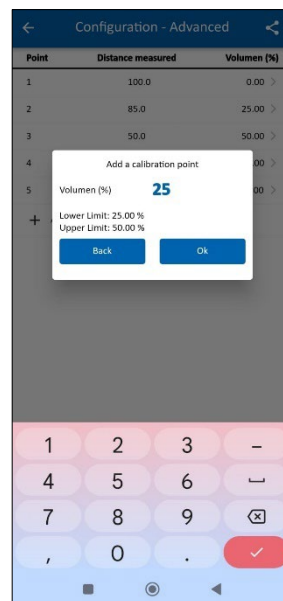

Figure 86

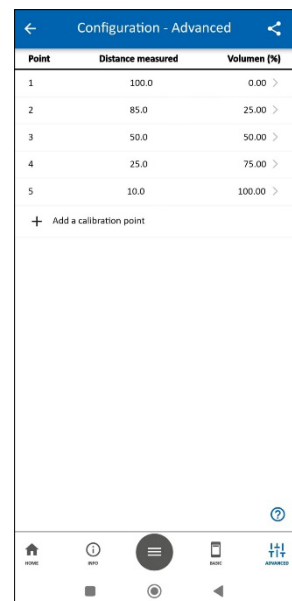

Figure 87

## 11 TECHNICAL SPECIFICATIONS

### 11.1 TL400-V

FEATURES	TL400-V
Dimensions	241.7 x 66 x 31 mm
Distance measurement	Configurable from 0 to 4000 mm
Accuracy	Maximum of 30 mm but can reach 2 mm if in good measuring conditions <sup>3</sup>
Resolution	1 millimeter
Blind spot	50 millimeters
Sampling	1 Hz
Sensor start-up	2.5 seconds
Output	0.5~4.5 Vdc with 1 mV resolution
Assembly	Standard SAE 5 holes or adapter for standard 4 holes
Consumption	<70 mA @ 12 V or <40 mA @ 24 V
Power supply	8~33 Vdc
Storage temperature	-20 to 80 °C (-4 to 176 °F)
Operation temperature	-20 to 80 °C (-4 to 176 °F)
Protection index	IP68
Housing	Polycarbonate
Software	<b>SigNow</b> (for PCs and smartphones)
Certifications	CE, LASER CLASS 1, ISO 16750-2

Table 7

### 11.2 TL400-I

FEATURES	TL400-I
Dimensions	241.7 x 66 x 31 mm
Distance measurement	Configurable from 0 to 4000 mm
Accuracy	Minimum of 30 mm but can reach 2 mm if in good measuring conditions <sup>4</sup>
Resolution	1 millimeter
Blind spot	50 millimeters
Sampling	1 Hz
Sensor start-up	2.5 seconds
Connector	M12 with 4 pins
Output	4-20 mA with 0.01 mA resolution
Assembly	Standard SAE 5 holes or adapter for standard 4 holes
Consumption	<70 mA @ 12 V or <40 mA @ 24 V
Power supply	8~33 Vdc
Storage temperature	-20 to 80 °C (-4 to 176 °F)
Operation temperature	-20 to 80 °C (-4 to 176 °F)
Protection index	IP68
Housing	Polycarbonate
Software	<b>SigNow</b> (for PCs and smartphones)

<sup>3</sup> A good measuring environment consists of a tank where the sensor can work at a maximum opening angle of 27°, without the incidence of sunlight. Factors that worsen the measurement conditions involve the reflectivity of the walls and bottom of the tank and the incidence of sunlight.

<sup>4</sup> A good measuring environment consists of a tank where the sensor can work at a maximum opening angle of 27°, without the incidence of sunlight. Factors that worsen the measurement conditions involve the reflectivity of the walls and bottom of the tank and the incidence of sunlight.

FEATURES	TL400-I
Certifications	CE, LASER CLASS 1, ISO 16750-2

Table 8

### 11.3 FACTORY DEFAULT

Both TL400 models come factory configured as follows:

SECTION	FACTORY DEFAULT	
	PARAMETER	VALUE
GENERAL	Level and distance: Unit	Centimeters
	Installation Offset	5.0 centimeters
	Tank height	395.0 centimeters
	Reverse output polarity	No
	Output minimum value	0.0 centimeters
	Output maximum value	400.0 centimeters
INPUT	Magnitude related to the analog output	Level
	Level and distance: Unit	Centimeters
	Installation Offset	5.0 centimeters
	Tank height	395.0 centimeters
	Field of view	27°
	Reading mode	Long
OUTPUT	Error action on the analog output	High
	Reverse output polarity	No
	Output minimum value	0.0 centimeters
	Output maximum value	400.0 centimeters
ADVANCED FILTER	Size of the main vector	100
	Size of the distance vector	80
	Median index	0
	Median size	40
	Show blocking filter parameters	No
	Acceptance percentage <sup>5</sup>	0.10 %
	Percentage increase <sup>6</sup>	0.05 %
	Acceptance counts <sup>7</sup>	8
First-order filter constant <sup>8</sup>	2	
SECURITY	Password	No password
COMMUNICATION	Device Tag	TL400

Table 9

<sup>5, 6, 7, 8</sup> Displayed when setting the «Show block filter parameters» parameter to «Yes».

## **11.4 CERTIFICATIONS**

### **CE MARK**

This is a Class A product. In a domestic environment, this product may cause radio interference in which case the user may be required to take adequate measures.

### **LASER CLASS 1**

The radiation used by the sensor is classified by IEC 60825-1:2014 as CLASS 1 LASER PRODUCT and does not present a risk to the human eye as long as you do not make any changes not described in the manual.

## 12 WARRANTY

Warranty conditions are available on our website [www.novusautomation.com/warranty](http://www.novusautomation.com/warranty).