

## AirGate Air+ and RHT Air+

USER GUIDE – V1.1x E



Recommended for devices with firmware version V 1.1x or higher.



<b>1</b>	<b>SAFETY ALERTS</b> .....	<b>4</b>
<b>2</b>	<b>PRESENTATION</b> .....	<b>5</b>
<b>3</b>	<b>IDENTIFICATION</b> .....	<b>6</b>
3.1	RHT AIR+: OVERVIEW .....	6
3.1.1	DISPLAY INFORMATIONS .....	7
3.1.2	OPERATION KEY.....	7
3.1.3	NAVIGATION SCREENS .....	7
3.1.4	MAIN SCREENS.....	8
3.1.5	INFO MENU .....	10
3.1.6	CONF MENU .....	14
3.1.7	SPEC MENU.....	16
3.2	AIRGATE AIR+: OVERVIEW.....	18
3.2.1	AP MODE OPERATION KEY .....	18
3.2.2	OPERATION LEDS .....	19
<b>4</b>	<b>INSTALLATION</b> .....	<b>20</b>
4.1	ELECTRICAL INSTALLATION.....	20
4.1.1	INSTALLATION RECOMMENDATIONS.....	20
4.1.2	RHT AIR+: POWER SUPPLY CONNECTIONS.....	20
4.1.3	AIRGATE AIR+: POWER SUPPLY CONNECTIONS.....	20
4.1.4	OTHER CONNECTIONS.....	21
4.2	AIRGATE AIR+: MECHANICAL INSTALLATION.....	21
4.2.1	PANEL OR DIN RAIL INSTALLATION.....	21
4.2.2	DIMENSIONS .....	22
4.3	RHT AIR: MECHANICAL INSTALLATION .....	23
4.3.1	DIMENSIONS .....	23
<b>5</b>	<b>COMMUNICATION INTERFACES</b> .....	<b>25</b>
5.1	USB INTERFACE .....	25
5.2	ETHERNET INTERFACE .....	25
5.3	WI-FI INTERFACE.....	25
<b>6</b>	<b>NOVUS AIR+ PROTOCOL</b> .....	<b>26</b>
6.1	PAIRING MODE .....	26
6.2	CHANNELS .....	26
6.3	SPREADING FACTOR.....	26
6.4	CONFIGURATION VIA HMI .....	26
<b>7</b>	<b>MQTT PROTOCOL</b> .....	<b>27</b>
7.1	CONNECTION.....	27
7.2	MQTT BROKER.....	27
7.3	DATA PUBLICATION .....	27
<b>8</b>	<b>SMTP PROTOCOL</b> .....	<b>29</b>
<b>9</b>	<b>MODBUS-TCP PROTOCOL</b> .....	<b>31</b>
9.1	COMMAND .....	31
9.2	ADDRESS (UNIT ID).....	31
9.3	TABLE OF REGISTERS.....	31
9.4	RHT AIR+: SLOT REGISTERS .....	34
<b>10</b>	<b>DEVICE: DATE/TIME</b> .....	<b>36</b>
10.1	RHT AIR+: DATE/TIME.....	36
10.2	AIRGATE AIR+: DATE/TIME .....	36
<b>11</b>	<b>CONFIGURATION SOFTWARE</b> .....	<b>37</b>
11.1	NXPERIENCE SOFTWARE.....	37
11.2	USING NXPERIENCE TO CONFIGURE YOUR AIRGATE AIR+ .....	37
11.2.1	GENERAL PARAMETERS.....	37
11.2.2	COMMUNICATION.....	38
11.2.3	ALARMS .....	42
11.2.4	AIR+ NETWORK.....	43
11.3	USING NXPERIENCE TO CONFIGURE YOUR RHT AIR+ .....	45
11.3.1	GENERAL PARAMETERS.....	45

11.3.2	CONNECTIONS.....	46
11.4	AIRGATE AIR+: DIAGNOSTIC .....	47
11.4.1	COMMUNICATION .....	47
11.4.2	RHT .....	48
11.4.3	INFORMATION .....	49
11.5	RHT AIR+: DIAGNOSTIC.....	49
11.5.1	LOGS .....	49
11.5.2	INFORMATION .....	50
11.5.3	INPUTS .....	50
11.5.4	CONNECTION.....	51
<b>12</b>	<b>USING RHT AIR+ AS A DATA LOGGER.....</b>	<b>52</b>
12.1	DATA LOGGER MODE.....	52
12.2	CONFIGURING NXPERIENCE .....	52
<b>13</b>	<b>TECHNICAL SPECIFICATION.....</b>	<b>53</b>
13.1	AIRGATE AIR+.....	53
13.2	RHT AIR+ .....	54
13.3	CERTIFICATIONS.....	55
<b>14</b>	<b>WARRANTY .....</b>	<b>57</b>
<b>15</b>	<b>ATTACHMENT I – NOTIONS OF PSYCHROMETRICS.....</b>	<b>58</b>
15.1	DRY BULB TEMPERATURE   [°C] oR [°F] .....	58
15.2	WET BULB TEMPERATURE   [°C] oR [°F].....	58
15.3	FROST POINT TEMPERATURE   [°C] oR [°F] .....	58
15.4	DEW POINT TEMPERATURE   [°C] oR [°F].....	58
15.5	SPECIFIC ENTHALPY   [kJ/kg] oR [BTU/lb].....	58
15.6	PARTIAL VAPOR PRESSURE [mbar] oR [psi] .....	58
15.7	MIXTURE RATIO   [g/kg] oR [gr/lb].....	58
15.8	RELATIVE HUMIDITY   [%RH] .....	58
15.9	ABSOLUTE HUMIDITY   [g/m <sup>3</sup> ] oR [gr/ft <sup>3</sup> ].....	58
15.10	HEAT INDEX   [°C] oR [°F].....	59

## 1 SAFETY ALERTS

The symbols below are used throughout this manual to draw the user's attention to valuable information related to device safety and use.

		
<b>CAUTION</b> Read the manual fully before installing and operating the device.	<b>CAUTION OR HAZARD</b> Risk of electric shock.	<b>ATTENTION</b> Electrostatic-sensitive device. Make sure you take the necessary precautions before handling it.

Safety recommendations must be followed to ensure personal safety and prevent damage to the equipment or system. If the equipment is used in a manner other than that specified in this manual, the safety precautions may not be effective.

## 2 PRESENTATION

The **Air+** line is formed by **AirGate Air+** and **RHT Air+** and its main purpose is to log and publish humidity and temperature data via MQTT at several points. Temperature and humidity data are recorded by **RHT Air+**, saved in a circular memory of up to 16,000 logs and sent to the linked **AirGate Air+**.

**AirGate Air+** and **RHT Air+** communicate via LoRa modulation and use a proprietary protocol called **NOVUS Air+**.

**RHT Air+** has a display with a backlight and 2 lines for displaying temperature and humidity values. It operates only on internal batteries and has a bracket for easy attachment to walls or metal surfaces. Battery lifespan is expected to be 2 years, considering a recording and publishing interval of 15 minutes.

You can use the multifunction key to configure it, linking it to an **AirGate Air+**. You can also use the USB interface to configure, collect data from memory and run diagnostics on the device.

**AirGate Air+** can manage up to 32 **RHT Air+**, saving up to 32,000 of the logs received from each **RHT Air+** in a circular memory. **AirGate Air+** has Ethernet and Wi-Fi interfaces, communication via Modbus-TCP, secure connection to **NOVUS Cloud** or MQTT Brokers, automatic clock setting and the ability to send alarm emails.

To simplify wireless configuration, the device has a button that allows you to temporarily enable a Wi-Fi Access Point, generated by **AirGate Air+** itself. You can also use the USB interface to configure it.

**RHT Air+** and **AirGate Air+** can be configured using software **NXperience**. Once the **RHT Air+** is properly linked to an **AirGate Air+**, you can manage the range of logs and define an ID tag for each **RHT**. In addition, it is possible to use your **AirGate Air+** to calculate psychrometric quantities based on humidity and temperature, such as dew point temperature, wet bulb temperature, frost temperature, absolute humidity, specific enthalpy, partial vapor pressure, mixing ratio, and heat index.

### 3 IDENTIFICATION

#### 3.1 RHT AIR+: OVERVIEW

RHT Air+ has a display and a multifunction key:

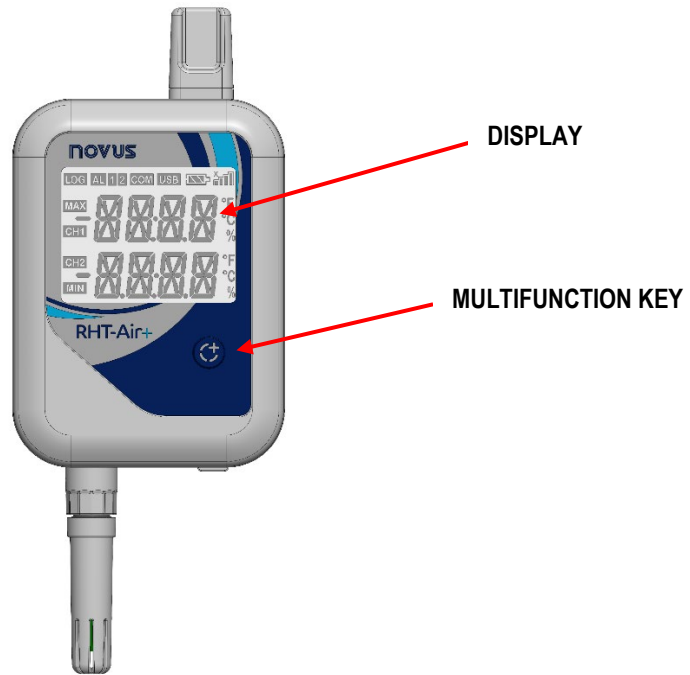

Figure 1

At the top, as shown in the figure above, is the antenna. At the bottom is the M12 connector, which receives the tip with the humidity and temperature measurement sensor. The USB Type-C connector is also on the underside, protected by a rubberized cover:











Figure 2

### 3.1.1 DISPLAY INFORMATIONS

RHT Air+ has an LCD display with two 4-digit number lines. In addition to channel information, the device has screens to display information and symbols.

To navigate between screens, use the multifunction key.

Below is a description of the function of each symbol:

- : Indicates the provisioning status of the RHT Air+ with the AirGate Air+ and the signal strength of wireless communication.
  - : If the icon is unlit, indicates that the RHT Air+ is not provisioned with any Gateway.
  - : Indicates that the device is not connected to the Gateway but is attempting to connect.
  - : Indicates the strength of the signal with which the AirGate Air+ receives the data sent by the RHT Air+.
- **USB**: Lights up when the USB cable is connected. Turns off when the USB cable is disconnected.
- **LOG**: Remains on from the moment the device makes its first log until it stops recording. It will blink when a log is made, turn off at the time of logging and turn on again.
- **AL 1 2**: No use.
- : Indicates the battery level. This symbol will be updated next to the recording and publishing interval.
  - : Battery above 75 %.
  - : Battery above 50 %.
  - : Battery above 25 %.
  - : Battery below 25 % (replace battery).
- **COM**: Blinks to indicate that a valid data packet has been received when communicating with the USB interface.
- **CH1, CH2**: Indicates the enabled channels and the information relating to the channel (temperature and humidity).
- **°F, °C**: If the channel unit is set to °F or °C, one of the symbols will light up when the channel is displayed. Otherwise, no unit symbol will be displayed.
- **MIN, MAX**: No use.

### 3.1.2 OPERATION KEY

To navigate between screens, use the multifunction key, which has different functions depending on the navigation screen:

- Short touch (less than 1 second):
  - If the display shows the mnemonic of the current screen, it advances to the next screen.
  - If the display shows screen information, it displays the current screen mnemonic again.
- Long press or key press (longer than 2 seconds or pressed):
  - Takes some action within the current screen.
  - Takes a second action within the current screen.

### 3.1.3 NAVIGATION SCREENS

To make it easier to identify the information on each screen, a mnemonic (visible for 3 seconds) will be displayed when you press the multifunction key. If the multifunction key is not pressed during this period, the current screen information will be displayed.



When the device is displaying information on a screen, simply press the key to advance to the next screen.

There is a time limit of 15 seconds for the information to be displayed. If the key is pressed, the device will automatically return to the main screen.

It is possible to trigger the configuration screens or special functions by making a long press or pressing the key for the time limit.

The tables below provide more information.

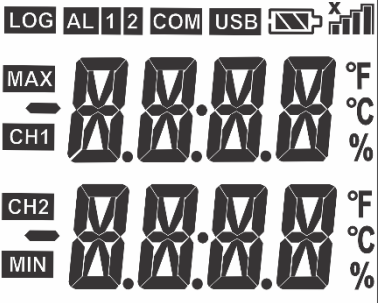
### 3.1.4 MAIN SCREENS

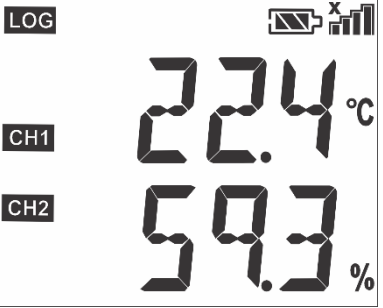
SCREEN	MNEMONIC	DESCRIPTION	KEY FUNCTION
1 Start-up Screen		<p>Displayed during device initialization.</p>	<p>No function.</p>
2 Waiting for Configuration		<p>Displayed after the device is initialized. The settings and logs are being loaded.</p> <p>Displayed when a new configuration is applied via USB or there is a demand for configuration or action via communication with the Gateway.</p>	<p>No function.</p>
3 Main Screen		<p>Displays current temperature and humidity information.</p>	<p>Probe Readings Update: When the multifunction key is pressed, the display will refresh the values immediately. However, these readings will not be logged at that moment. They are only recorded at the configured logging interval. Additionally, the screen will only update if at least 10 seconds have passed since the previous key press.</p>









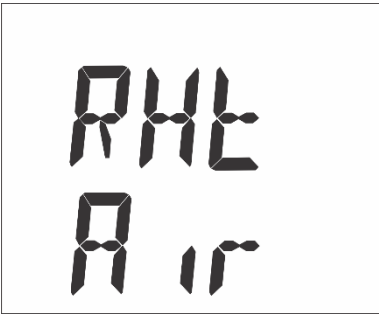
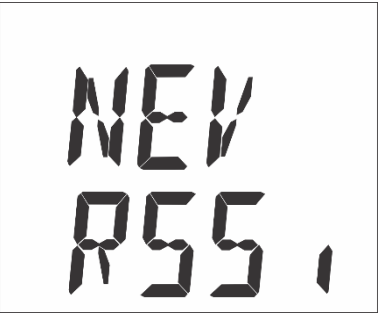

SCREEN	MNEMONIC	DESCRIPTION	KEY FUNCTION
<p>4 Selection Menu for New Screens</p>	 <p>The MNEMONIC column contains three separate rectangular boxes, each representing an LCD screen. The top box displays 'MENU' on the first line and 'INFO' on the second line. The middle box displays 'MENU' on the first line and 'CONF' on the second line. The bottom box displays 'MENU' on the first line and 'SPEC' on the second line. All text is in a large, black, monospace-style font.</p>	<p>Displays the configuration menus. See <a href="#">INFO MENU</a>, <a href="#">CONF MENU</a>, and <a href="#">SPEC MENU</a>.</p>	<p>Navigate through the screens to the desired menu. If the key is not pressed for up to 3 seconds, the device will display the first screen of the respective menu.</p>

Table 1

### 3.1.5 INFO MENU

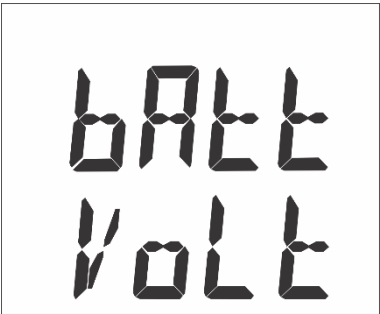
SCREEN	MNEMONIC	INFORMATION	DESCRIPTION	KEY FUNCTION
1 RHT Air+ Serial Number	RHT SN	1234 5678	Displays the serial number of the device.	<b>Short touch:</b> Advances to the next screen.
2 Firmware Version	Firm VER	rEV 1.00	Displays the firmware version of the device.	<b>Short touch:</b> Advances to the next screen.
3 Sensor Probe Serial Number	Prob SN	2307 4951	Displays the serial number of the sensor connected to the device via M12 connector.	<b>Short touch:</b> Advances to the next screen.

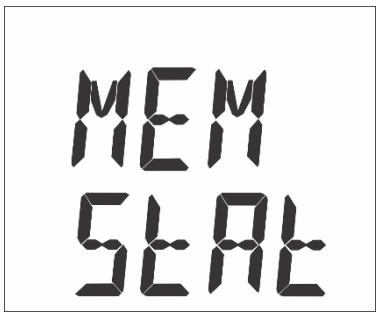
SCREEN	MNEMONIC	INFORMATION	DESCRIPTION	KEY FUNCTION
4 Device Tag			<p>Displays the tag configured for the device. This Tag is used as a complement to the topic of periodic publication and alarms to send data via MQTT through an <b>AirGate Air+</b>.</p>	<p><b>Short touch:</b> Advances to the next screen.</p>
5 Communication Signal Strength Level			<p>Displays the strength of the wireless communication signal with which the <b>AirGate Air+</b> receives the message from an RHT.</p>	<p><b>Short touch:</b> Advances to the next screen.</p>
6 Battery Discharge Level			<p>Displays the discharge level of the batteries.</p>	<p><b>Short touch:</b> Advances to the next screen.</p>

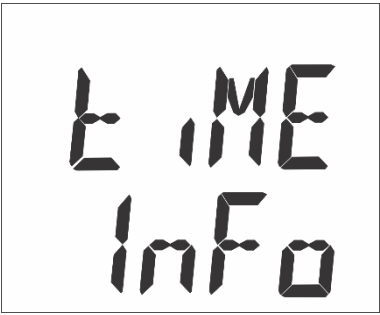
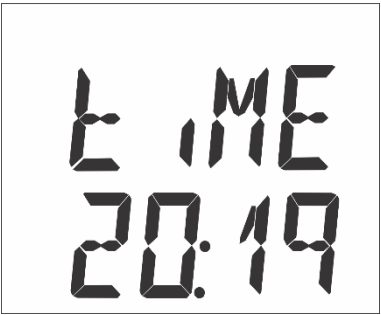
SCREEN	MNEMONIC	INFORMATION	DESCRIPTION	KEY FUNCTION
7 Battery voltage			Displays the battery voltage.	<b>Short touch:</b> Advances to the next screen.
8 Amount of Memory Used for Logs			Displays the percentage of use of the internal memory for storing periodic logs. If 100 %, it can be interpreted as an indication that the device is recording periodic data in circular memory.	<b>Short touch:</b> Advances to the next screen.
9 Device Clock: Time			Displays the time and minutes of the clock in 24-hour configuration.	<b>Short touch:</b> Advances to the next screen.







SCREEN	MNEMONIC	INFORMATION	DESCRIPTION	KEY FUNCTION
			Displays the time and minutes of the clock in AM / PM configuration.	<b>Short touch:</b> Advances to the next screen.
10 Device Clock: Date			Displays the date of the clock. The data can be displayed in 3 formats: 1) DD.MM YYYY 2) MM.DD YYYY or 3) YYYY MM.DD	<b>Short touch:</b> Advances to the next screen.
11 Return to the main screen			If you select this screen and do not press the key for 3 seconds, the device will exit the submenu and return to the main screen.	<b>Short press:</b> Advances to the next screen. At the end, it returns to the first screen of this submenu.

Table 2

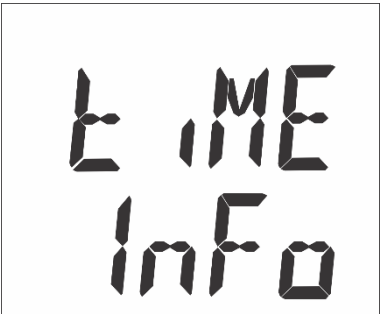
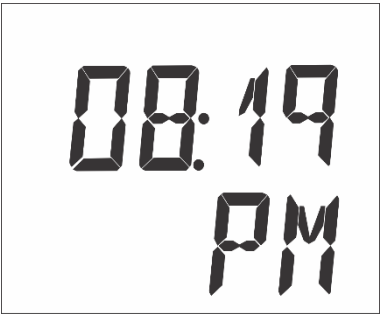
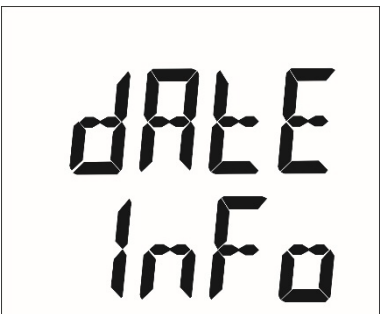
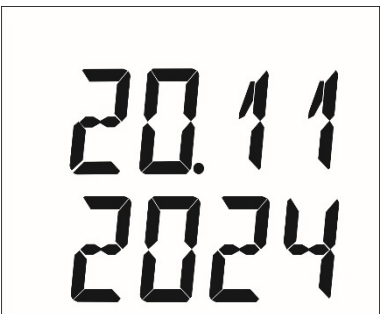
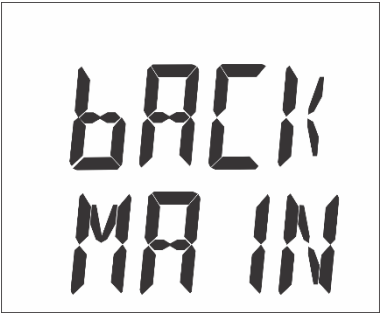
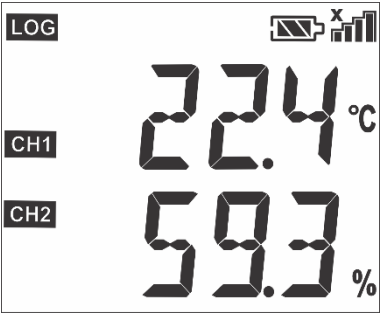
### 3.1.6 CONF MENU

SCREEN	MNEMONIC	INFORMATION	DESCRIPTION	KEY FUNCTION
1 Network Channel			Displays the wireless communication network channel on which the RHT Air+ is configured to operate.	<p><b>Short touch:</b> Advances to the next screen.</p> <p><b>Long press or press and hold the key for at least 2 seconds:</b> The device will enter edit mode. The data in the second line will flash.</p> <p><b>Short touch when editing:</b> Advances the field setting value to the next valid value. If it is in the last one, it returns to the first valid value.</p>
2 Network Spreading Factor			Displays the value of the wireless communication spreading factor.	<p>To confirm the setting after reaching the desired value, press the key and hold it down for at least 2 seconds (until the data on the display stops flashing). When you release the key, the configuration will take effect, and the <b>Waiting for Configuration</b> screen will be displayed.</p> <p>The <b>Network Channel</b> and <b>Network Spreading Factor</b> screens will not enter edit mode if the RHT Air+ is already provisioned to an <b>AirGate Air+</b>.</p>
3 Radio Transmission Power			Displays the output power of the wireless communication module/radio.	<p>The <b>Radio Transmission Power</b> screen can enter edit mode in any condition. However, this may restart the connection process with the <b>AirGate Air+</b>.</p>

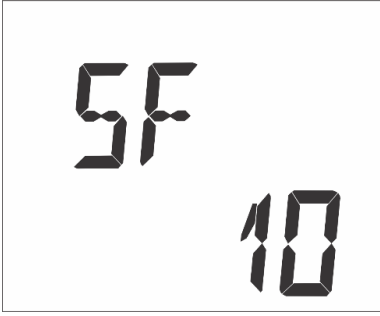





SCREEN	MNEMONIC	INFORMATION	DESCRIPTION	KEY FUNCTION
4 Display: Backlight Level			Displays the level and intensity of the backlight.	<p><b>Short touch:</b> Advances to the next screen.</p> <p><b>Long press or press and hold the key for at least 2 seconds:</b> The device will enter edit mode. The data in the second line will flash.</p> <p><b>Short touch when editing:</b> Advances the field setting value to the next valid value. If it is in the last one, it returns to the first valid value.</p>
5 Backlight: On Time			Displays the time (in seconds) that the backlight will remain active after the key is pressed.	<p>To confirm the setting after reaching the desired value, press the key and hold it down for at least 2 seconds (until the data on the display stops flashing).</p> <p>By setting the Backlight level to 0 on the Display Backlight Level screen, the Backlight trigger control will be disabled.</p>
6 Return to Main Screen			If you select this screen and do not press the key for 3 seconds, the device will exit the submenu and return to the main screen.	<p><b>Short press:</b> Advances to the next screen. At the end, it returns to the first screen of this submenu.</p>

Table 3

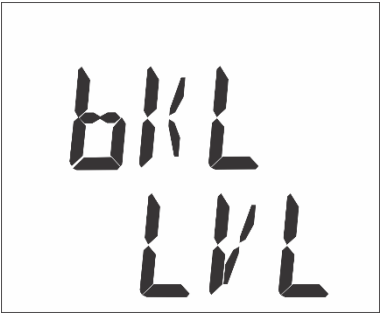
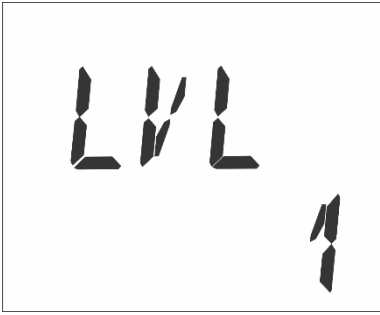
### 3.1.7 SPEC MENU

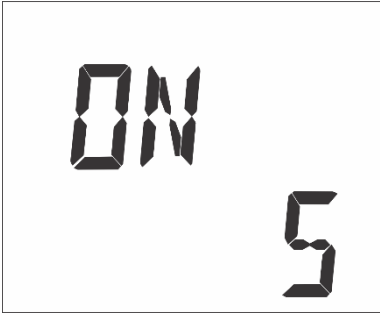
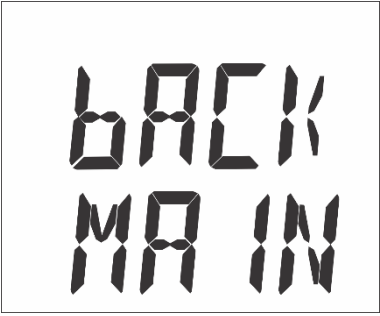
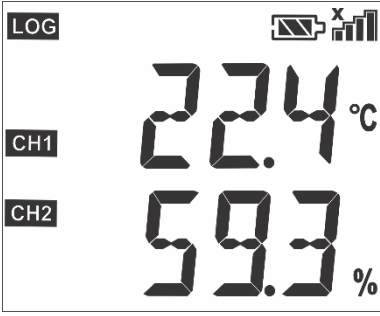
SCREEN	MNEMONIC	INFORMATION	DESCRIPTION	KEY FUNCTION
1 Turn off the device			Allows you to turn off the device.	<p><b>Short touch:</b> Advances to the next screen.</p> <p><b>Long press or press and hold the key for at least 2 seconds:</b> The device will initialize the shutdown process, entering stand-by mode.</p> <p>The LCD display will be turned off when the operation is complete.</p> <p>To turn the device back on, press and hold the key for at least 4 seconds.</p>
2 Forcing a connection with an AirGate Air+			Allows you to force a connection with an <b>AirGate Air+</b> .	<p><b>Short touch:</b> Advances to the next screen.</p> <p><b>Long press or press and hold the key for at least 2 seconds:</b> The process of connecting to the <b>AirGate Air+</b> will restart and the device will automatically return to the main screen.</p>
3 Reset battery consumption control			<p>Allows you to reset the battery consumption control.</p> <p>Its status will return to 100 % and the device will automatically return to the main screen.</p> <p>This action is required whenever the batteries are replaced.</p>	<p><b>Short touch:</b> Advances to the next screen.</p> <p><b>Long press or press and hold the key for at least 2 seconds:</b> The device will reset the consumption and discharge controls of the batteries.</p>

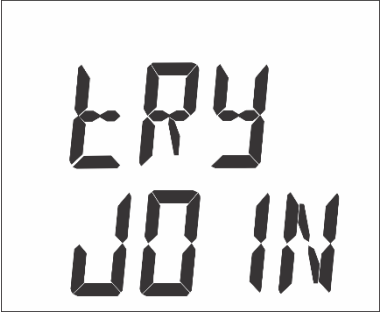
SCREEN	MNEMONIC	INFORMATION	DESCRIPTION	KEY FUNCTION
4 Return to Main Screen			<p>If you select this screen and do not press the key for 3 seconds, the device will exit the submenu and return to the main screen.</p>	<p><b>Short press:</b> Advances to the next screen. At the end, it returns to the first screen of this submenu.</p>

Table 4

### 3.2 AIRGATE AIR+: OVERVIEW

On its front, **AirGate Air+** has 3 operation LEDs (see [OPERATION LEDs](#)):

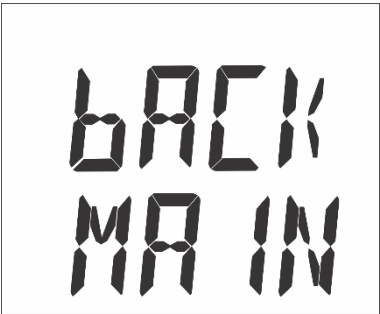
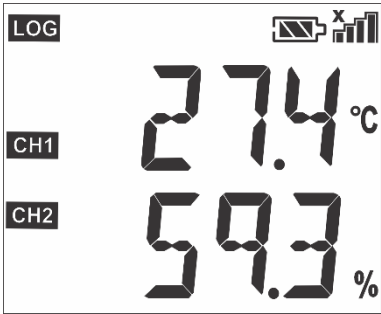

Figure 3

On the side, you'll find the SMA connector for the antenna and the USB Type-C connector. Under the protective cover are the power supply connector, the Ethernet cable connector and the AP Mode key:

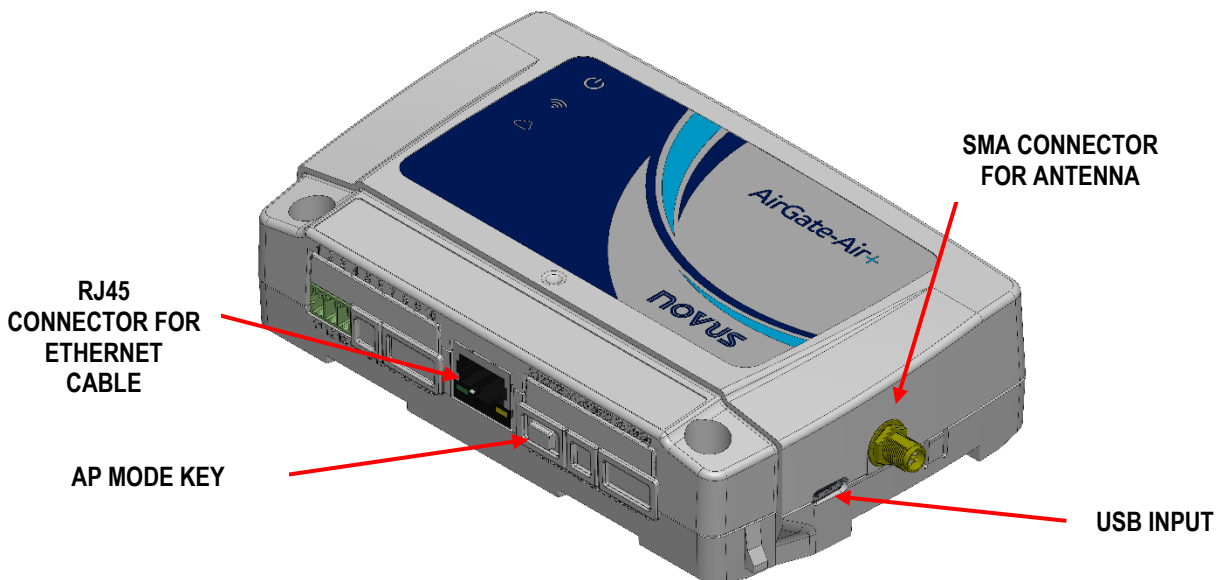

Figure 4

#### 3.2.1 AP MODE OPERATION KEY

The AP Mode button allows you to enable the Wi-Fi network generated by the device:

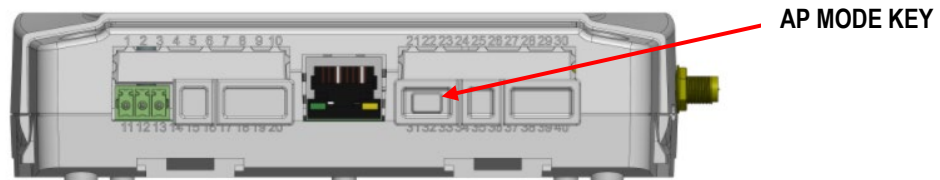

Figure 5

The Access Point mode generates a Wi-Fi access point named **AirGateAir\_SN**. In it, the SN corresponds to the serial number of the device. The default password for the Wi-Fi access point is its serial number, but you can change it by using the **NXperience** software (see the [COMMUNICATION](#) section of [CONFIGURATION SOFTWARE](#)).

When AP Mode is active, you can connect to the **AirGate Air+** via Wi-Fi. This allows you to configure it, download data and make diagnostics using **NXperience** via Modbus-TCP. The IP for accessing the device is 192.168.4.1.

It is possible to define whether AP Mode will always be enabled or disabled, or whether it will be automatically switched off after 3 minutes if there is no connection to the device.

### 3.2.2 OPERATION LEDS

AirGate Air+ has 3 LEDs, which indicate the operational status, as shown in the figure below:

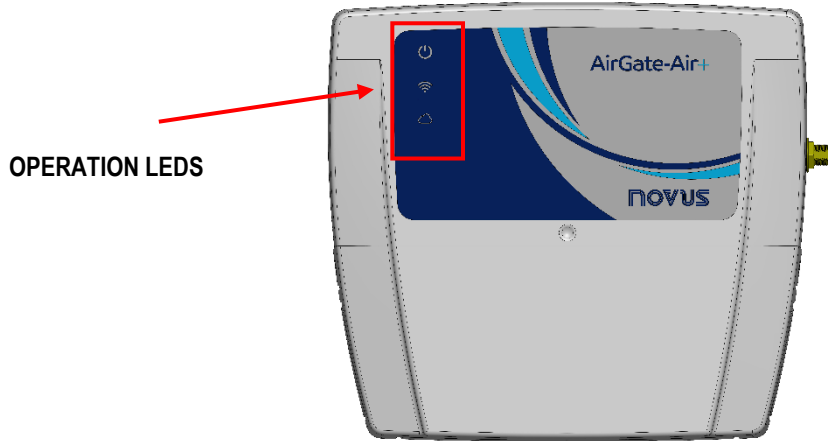

Figure 6

The operation and description of each LED are described below:



NAME	SYMBOL	STATUS	DESCRIPTION
STATUS		Off	The device is off.
		On	The device is on.
		Flashing	The device is in firmware update mode.
CONNECTION INDICATOR WI-FI / ETHERNET VIA TCP/IP NETWORK		On	The connection has been established.
		Flashing	The data is being transmitted via Modbus-TCP.
		Off	The connection has not been established.
MQTT BROKER CONNECTION INDICATOR		On	The connection has been established.
		Flashing	The data is being transmitted.
		Off	The connection is disabled or failed to initialize.

Table 5

## 4 INSTALLATION

### 4.1 ELECTRICAL INSTALLATION

#### 4.1.1 INSTALLATION RECOMMENDATIONS

- Electronic and analog signal conductors should run through the plant separately from the output and supply conductors. If possible, in grounded conduits.
- The power supply for electronic instruments must come from a network specific to the instrumentation.
- It is recommended to use RC FILTERS (noise suppressors) in contactor coils, solenoids, etc.
- In control applications, it is essential to consider what can happen when any part of the system fails. The internal safety features of the equipment do not guarantee full protection.
- You must detach the connection terminals before making the electrical connections. Before connecting them, make sure that the connections have been made correctly.

#### 4.1.2 RHT AIR+: POWER SUPPLY CONNECTIONS

RHT Air+ is powered by batteries, located inside the housing. To access them, remove the 4 screws on the back of the device:

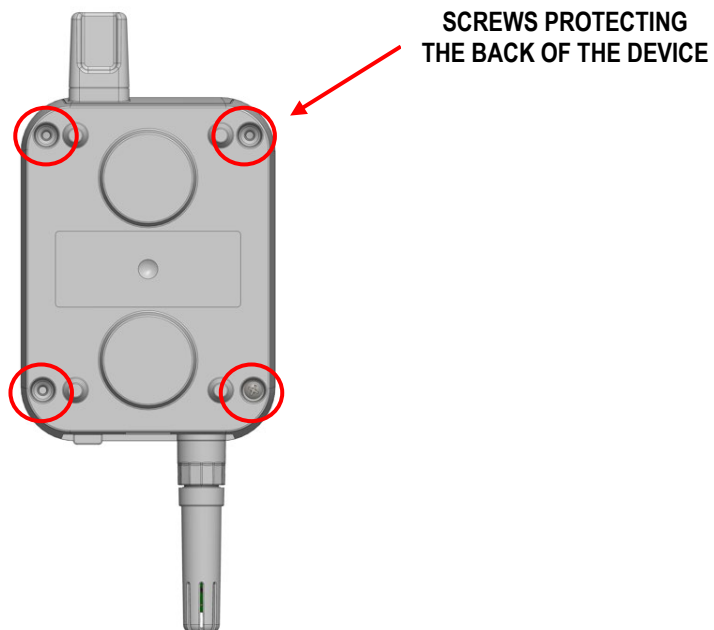

Figure 7

#### 4.1.3 AIRGATE AIR+: POWER SUPPLY CONNECTIONS

AirGate Air+ must be powered by an external power supply, which must be connected to the power input, as shown in the figure below:

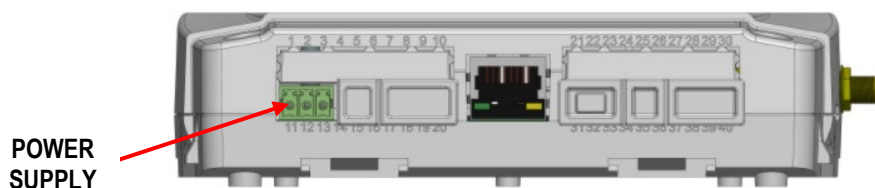
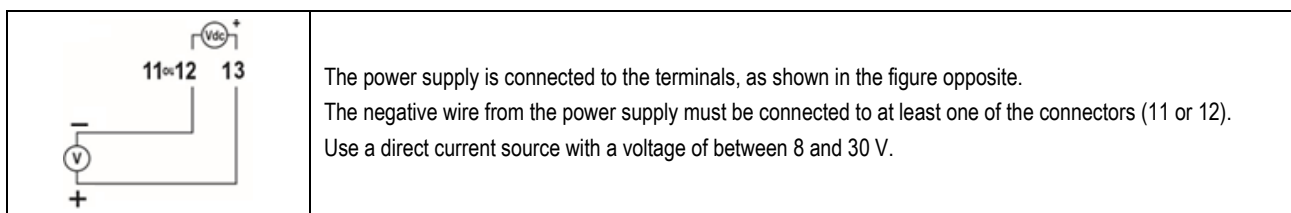

Figure 8

The connection must be made as follows:



#### 4.1.4 OTHER CONNECTIONS

RHT Air+ has a 4-way M12 connector for mounting the humidity and temperature sensor tip:

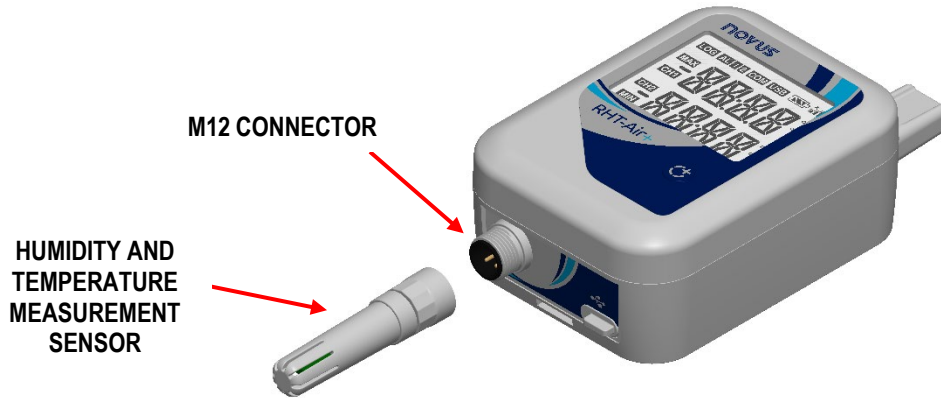

Figure 9

AirGate Air+ has 1 RJ45 connector for the Ethernet cable and 1 SMA connector for the antenna:

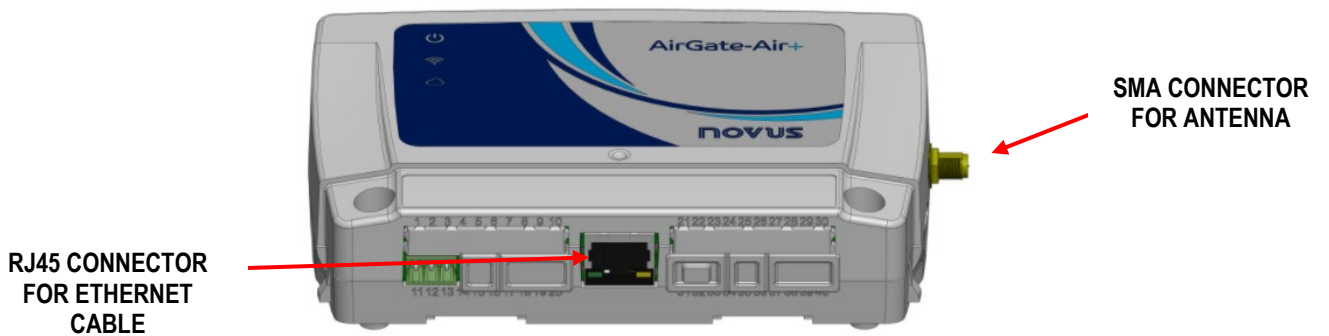

Figure 10

## 4.2 AIRGATE AIR+: MECHANICAL INSTALLATION

### 4.2.1 PANEL OR DIN RAIL INSTALLATION

As shown in the figure below, AirGate Air+ can be installed on a 35 mm DIN rail. To attach it, use the rear clips:

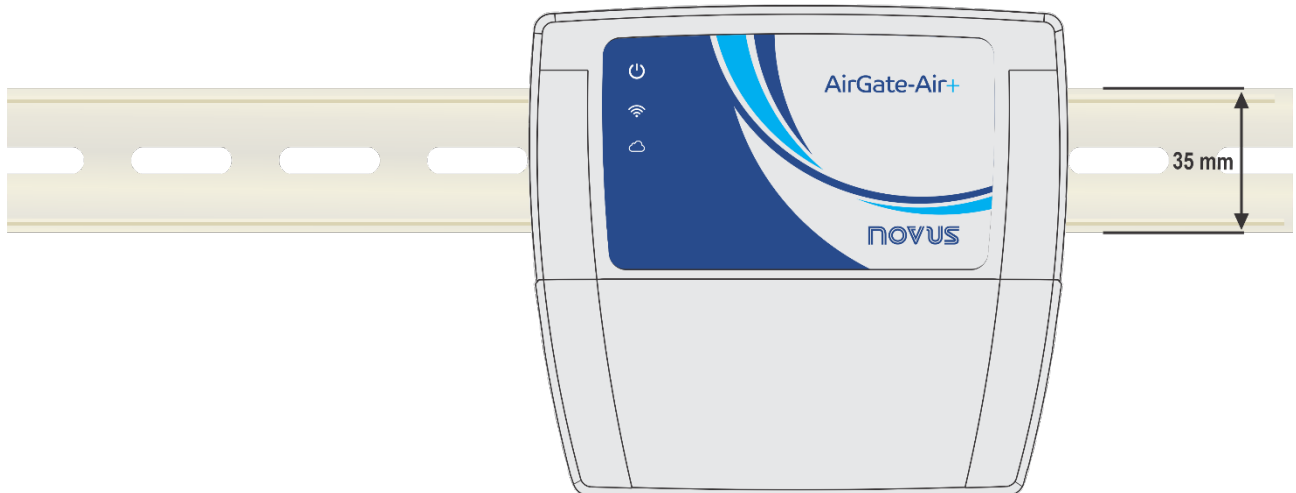

Figure 11

The device also has 2 holes, which allow it to be fixed with screws, as shown in the figure below:

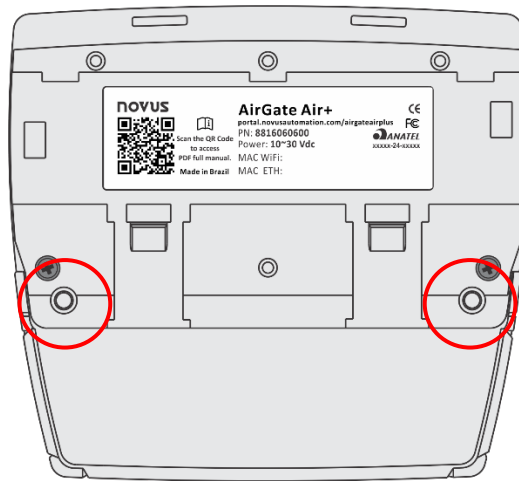

Figure 12

**AirGate Air+** has a removable cover to protect the connection terminals. The protective cover has 3 detachable areas (1 at the bottom and 1 on each side), which make it easier to pass the sensors through:

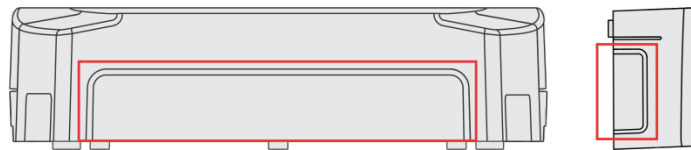

Figure 13

The protective cover has 2 pins, located on the sides of the housing, to make it easier to fit onto the body of the device. Once the cover has been installed, use a screwdriver to remove it.

#### 4.2.2 DIMENSIONS

**AirGate Air+** has the following dimensions:

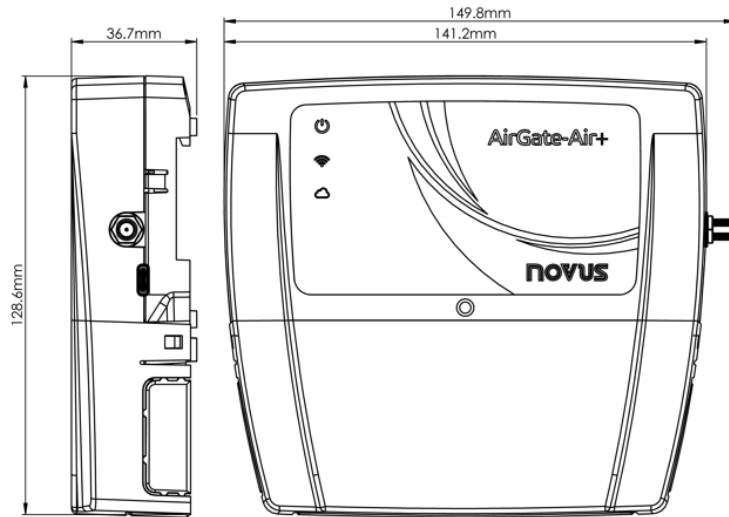

Figure 14

### 4.3 RHT AIR: MECHANICAL INSTALLATION

RHT Air+ has a bracket with 4 holes, used to secure it with screws. In addition, there are also 2 magnets, which allow the device to be attached to metal surfaces:

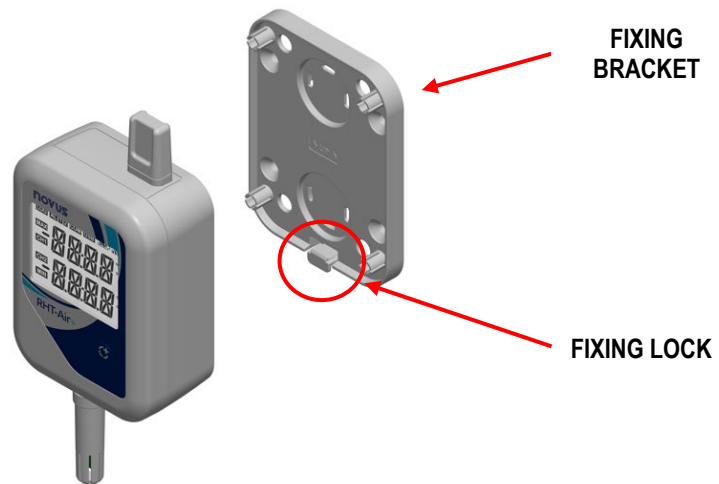

Figure 15

To fit the RHT Air+ into the bracket, simply press it down until you hear the lock click:



Figure 16

Before finalizing the installation, it is important to check that the device is locked in the bracket.

#### 4.3.1 DIMENSIONS

RHT Air+ has the following dimensions:

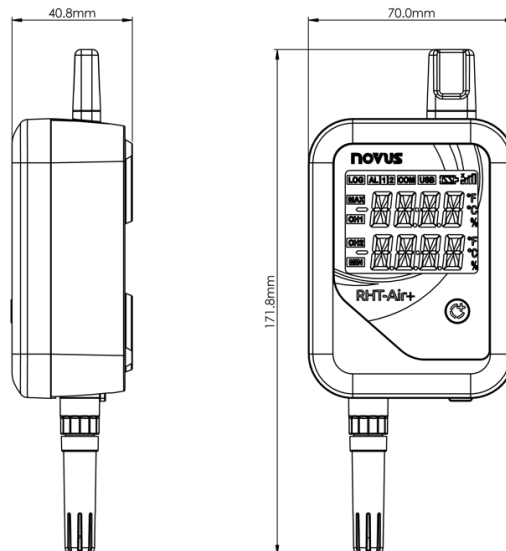

Figure 17

The fixing bracket has the following dimensions:

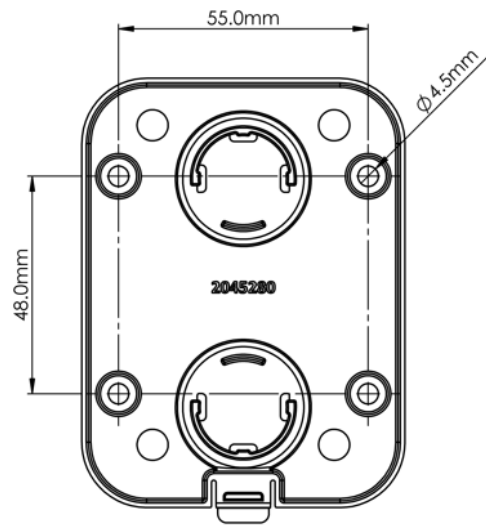

Figure 18

## 5 COMMUNICATION INTERFACES

### 5.1 USB INTERFACE

**AirGate Air+** and **RHT Air+** have a USB interface. It is located on the side of the **AirGate Air+** housing. It is located at the bottom of the **RHT Air+** housing.

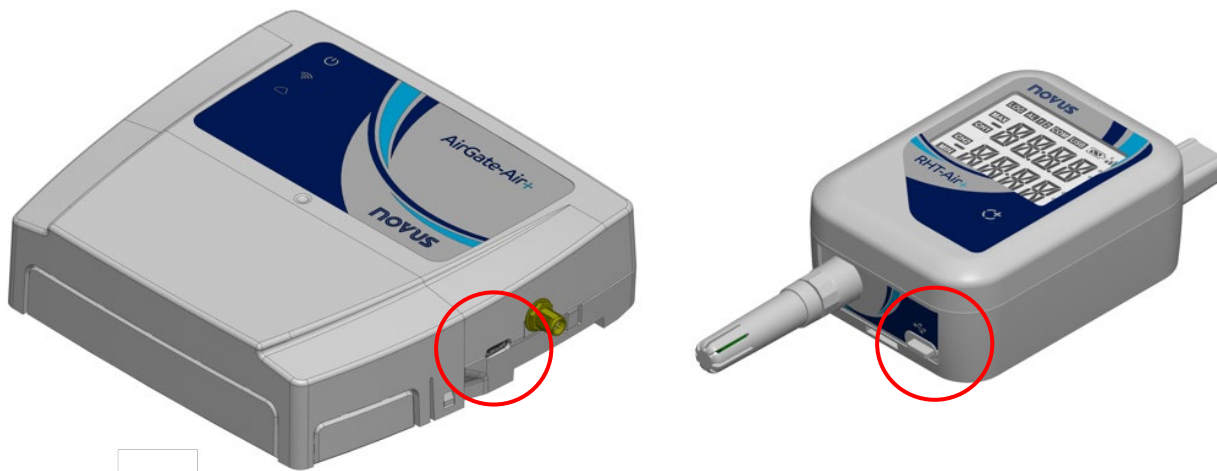

Figure 19

The USB interface must be used to configure, download data from memory and diagnose the operation of the device using **NXperience** (see [CONFIGURATION SOFTWARE](#)). To connect the **AirGate Air+** and the **RHT Air+** to a computer, use a USB cable in the USB-C standard (not supplied).

During the installation of the configuration software, the USB drivers will be automatically installed.

	<ol style="list-style-type: none"><li>1. The USB interfaces of the devices are <u>not</u> isolated.</li><li>2. In <b>AirGate Air+</b>, the purpose is for temporary use during <b>CONFIGURATION</b>, <b>DATA COLLECTION</b> and <b>DIAGNOSTICS</b> of the device.</li><li>3. <b>AirGate Air+</b> and <b>RHT Air+</b> are only compatible with <b>NXperience</b> software. It is not possible to use proprietary software to configure, collect data or perform diagnostics on the devices.</li></ol>
--	--

### 5.2 ETHERNET INTERFACE

**AirGate Air+** has an Ethernet interface, located next to the terminals, as shown in the figure below:

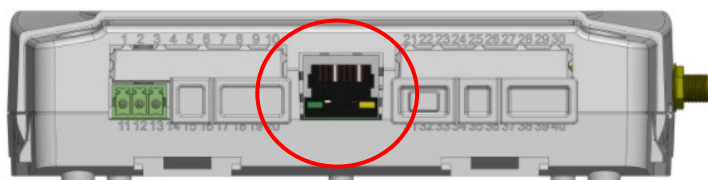



Figure 20

If the Ethernet interface is enabled and the device is connected to an Ethernet network, the  LED on the front of the device will remain on. If data is being sent via this interface, this LED will remain on and blinking.

### 5.3 WI-FI INTERFACE

**AirGate Air+** has an 802.11 b/g/n 2.4 GHz Wi-Fi interface that operates via an internal antenna. This interface supports WPA-Personal (PSK) WPA/WPA2 TKIP/AES/TKIP and AES encryption.

If the Wi-Fi interface is enabled and the device is connected to a Wi-Fi network, the  LED on the front of the device will remain on. If data is being sent via this interface, this LED will remain on and blinking.

## 6 NOVUS AIR+ PROTOCOL

**AirGate Air+** and **RHT Air+** communicate via a proprietary protocol called **NOVUS Air+**. **NOVUS Air+** is an encrypted wireless protocol that operates using LoRa modulation and 902.5 to 907 MHz frequencies for optimum power consumption and coverage area.

### 6.1 PAIRING MODE

As soon as it is initialized and if it is not already linked to an **AirGate Air+**, the **RHT Air+** will use Broadcast commands to begin the process of searching for an **AirGate Air+**. Once it has communicated with an **AirGate Air+**, it will be necessary to approve the pairing, which can be done in 2 ways:

1. Through **NXperience**, by checking the connection requests of the **RHT Air+** on the network (see [CONFIGURATION SOFTWARE](#)).
2. Manually, like a previous registration of **RHTs** with reserved slots on **AirGate Air+**.

If you do not complete the pairing between **RHT Air+** and **AirGate Air+** within a maximum of 2 hours, the **RHT Air+** will automatically switch off to avoid compromising the internal battery. It will only start operating again once the multifunction key is pressed.

Once the pairing has been completed, it will be possible to change the settings of your **RHTs**. It is possible to set an ID tag, configure a log interval, define the measurement unit and the number of decimal places, for example, by accessing the **AirGate Air+** configuration area (see [CONFIGURATION SOFTWARE](#)).

### 6.2 CHANNELS

Within the operating frequency range of the devices, the spectrum was divided into channels. This allows more than one **Air+** network to be overlaid on the same site. Thus, when expanding the number of devices or operating with neighboring **Air+** networks within the coverage area, it is necessary to use exclusive channels for each **Air+** network.

The number of channels available for configuration depends on the device model (see [TECHNICAL SPECIFICATIONS](#)).



Within the **Air+** network, both the **AirGate Air+** and the **RHT Air+** paired with it must be tuned to the same channel.

### 6.3 SPREADING FACTOR

In addition to the channel, it is also necessary for the devices within the **Air+** network to operate on the same Spreading Factor (SF), a parameter that determines the communication robustness through the time in which packets will be transmitted. The higher the SF level, the longer it takes to transmit a packet and the greater the energy consumption.

By default, devices are shipped with SF set to 10. You can adjust the value based on the performance of your **Air+** network.

### 6.4 CONFIGURATION VIA HMI

When commissioning an **RHT Air+**, you can use the display and the multifunction key to adjust the operating channel, SF value and other parameters. When paired with an **AirGate Air+**, however, parameter editing via HMI becomes unavailable. From then on, it will only be possible to change them via USB.

## 7 MQTT PROTOCOL

**AirGate Air+** is compatible with versions 3.1 and 3.1.1 of the Message Queue Telemetry Transport (MQTT) protocol, a communication protocol that allows data to be published in the cloud and even connects the device to supervisory control and data acquisition (SCADA) systems.

**AirGate Air+** currently supports communication with **NOVUS Cloud**, generic MQTT Brokers and AWS. It is compatible with TLS 1.2 encryption.

There is no interface priority in the MQTT connection. When you connect to a network on the interface (whether Ethernet or Wi-Fi), the device will try to establish a connection with the MQTT Broker. The connection to the MQTT Broker will be maintained on only one of the interfaces and will remain unchanged as long as no connectivity problems are identified.

### 7.1 CONNECTION

The MQTT connection will be made via the Ethernet and Wi-Fi interfaces. For **AirGate Air+** to search for a connection to the MQTT Broker, there must be an established connection to the router.

As there is no interface priority in the connection, the interface will only be switched if there are problems in the connection established with the MQTT Broker.

### 7.2 MQTT BROKER

If there is a connection to the MQTT Broker, temperature and humidity data from the **RHT Air+** will be transmitted immediately to the MQTT Broker. If the connection to the Broker is not operational or there is a problem during publication, the temperature and humidity data will be stored in a circular memory, which will allow them to be published later. This will also allow them to be collected whenever necessary.

### 7.3 DATA PUBLICATION

You can configure the header of the topic to which **AirGate Air+** will publish (see the [COMMUNICATION](#) section of [CONFIGURATION SOFTWARE](#)). However, the **RHT Air+** tag (from which the humidity and temperature data originated) will always be concatenated.

Periodic data will be published in JSON format with the following fields:

```
{
  "id_ag": 23038212,
  "id_rht": 23119626,
  "tag_ag": "AirGate Air+",
  "tag_rht": "RHT Air+",
  "slot": 1,
  "periodic": {
    "timestamp": 1585819219,
    "status": "ok",
    "temperature": 23.4,
    "humidity": 70.3,
    "dew_point": 12.2
  }
}
```

The name of the field related to the calculated channel will depend on the configuration made, and can assume the following values:

- dew\_point
- partial\_vapor
- wet\_bulb
- abs\_humidity
- mix\_ratio
- spec\_enthalpy
- frost\_point
- heat\_index

You can also configure the device to make an exclusive MQTT publication to signal the alarm. The topic will follow the pattern of setting up a header. In it, **AirGate Air+** will concatenate the **RHT Air+** tag that triggered the alarm into the topic. Alarm data will be published in JSON format, with the following fields:

```
{
  "id_ag": 23038212,
  "id_rht": 23119626,
  "tag_ag": "AirGate Air+",
  "tag_rht": "RHT Air+",
  "slot": 1,
  "alarm": {
    "timestamp": 1585819219,
    "type": "high_temp",
    "temperature": 23.4,
    "limit": 30.1,
    "offset": -0.4
  }
}
```

## 8 SMTP PROTOCOL

**AirGate Air+** is compatible with the Simple Mail Transfer Protocol (SMTP), a protocol designed to send emails over the Internet via an email server (such as Gmail, Outlook, and Yahoo!).

This feature allows sending emails to up to 10 previously registered recipients during alarm situations configured and specified in **NXperience** (see the [ALARMS](#) section of [CONFIGURATION SOFTWARE](#)).

Emails sent using this protocol will contain the message configured in the [COMMUNICATION](#) tab of **NXperience**, as can be seen in the example below:

From: [airgate-airplus@outlook.com](mailto:airgate-airplus@outlook.com)  
 Submitted: Monday, April 01, 2024, 04:12  
 To: [novus@novusautomation.com](mailto:novus@novusautomation.com)  
 Subject: Alarm Alert

HUMIDITY/TEMPERATURE OUT OF LIMITS

AirGate Warehouse  
 RHT 1 – Waiting Room

HIGH TEMPERATURE  
 TEMPERATURE: 30.8 Celsius  
 LIMIT: 25.7 + 4.0 Celsius

Mon, Apr 01, 2024. 04:11:59 PM

Each email should be displayed as follows:

<b>Message header</b>		From: <a href="mailto:airgate-airplus@outlook.com">airgate-airplus@outlook.com</a> Submitted: Monday, April 01, 2024, 04:12
<b>Recipient</b>		To: <a href="mailto:novus@novusautomation.com">novus@novusautomation.com</a>
<b>Subject</b>		Subject: Alarm Alert
<b>Common part of the message</b>		HUMIDITY/TEMPERATURE OUT OF LIMITS
<b>Alarm Information</b>	<b>AirGate Air+ Tag</b>	AirGate Warehouse
	<b>Slot and Tag of the RHT that caused the alarm</b>	RHT 1 – Waiting Room
	<b>Alarm type</b>	HIGH TEMPERATURE
	<b>Values involved in the alarm</b>	TEMPERATURE: 30.8 Celsius LIMIT: 25.7 + 4.0 Celsius
	<b>Alarm time</b>	Mon, Apr 01, 2024. 04:11:59 PM

Table 6

Each email has parameters that can be configured in **NXperience**, as you can see on the table below:

PART OF THE MESSAGE	NXPERIENCE
From: <a href="mailto:airgate-airplus@outlook.com">airgate-airplus@outlook.com</a> Submitted: Monday, April 01, 2024, 04:12	This corresponds to the sender of the email, which must be configured in the <a href="#">COMMUNICATION</a> tab of <b>NXperience</b> , and the date and time the message was sent.
To: <a href="mailto:novus@novusautomation.com">novus@novusautomation.com</a>	This corresponds to the email address of the recipient, selected in the <b>Alarm Actions</b> section for each alarm configured in the <a href="#">ALARMS</a> tab of <b>NXperience</b> . It is possible to select up to 10 contacts from your address book.
Subject: Alarm Alert	This corresponds to the title of the email, which must be configured in the <a href="#">COMMUNICATION</a> tab of <b>NXperience</b> .
HUMIDITY/TEMPERATURE OUT OF LIMITS	This corresponds to the text defined as the common part of the email message, which must be configured in the <a href="#">COMMUNICATION</a> tab of <b>NXperience</b> .
AirGate Warehouse	This corresponds to the tag given to the device in the <a href="#">GENERAL PARAMETERS</a> tab of <b>NXperience</b> .
RHT 1 – Wait Room	The first field corresponds to the slot assigned to <b>RHT Air+</b> at the time of registration in the <a href="#">AIR+ NETWORK</a> tab of <b>NXperience</b> .

PART OF THE MESSAGE	NXPERIENCE
	The second field corresponds to the Tag assigned to the <b>RHT Air+</b> , which can be seen in the <a href="#">GENERAL PARAMETERS</a> tab of the <b>RHT Air+</b> and in the <a href="#">AIR+ NETWORK</a> tab of the <b>AirGate Air+</b> .
HIGH TEMPERATURE	This corresponds to the type of alarm enabled in the <a href="#">ALARMS</a> tab of <b>NXperience</b> . The alarm types are: <ul style="list-style-type: none"> <li>• HIGH TEMPERATURE: High temperature alarm.</li> <li>• LOW TEMPERATURE: Low temperature alarm.</li> <li>• HIGH HUMIDITY: High humidity alarm.</li> <li>• LOW HUMIDITY: Low humidity alarm.</li> <li>• HIGH DEW POINT: High dew point alarm. It depends on the type of variable calculated by humidity and temperature.</li> <li>• LOW DEW POINT: Low dew point alarm. It depends on the type of variable calculated by humidity and temperature.</li> </ul>
TEMPERATURE: 30.8 Celsius LIMIT: 25.7 + 4.0 Celsius	This corresponds to the reading that generated the alarm, the limit value, and the Offset value configured in the <a href="#">ALARMS</a> tab of <b>NXperience</b> .
Mon, Apr 01, 2024. 04:11:59 PM	This corresponds to the date and time format in which the alarm occurred and which can be defined in the <a href="#">GENERAL PARAMETERS</a> tab of <b>NXperience</b> .

Table 7

## 9 MODBUS-TCP PROTOCOL

**AirGate Air+** is compatible with the Modbus-TCP protocol, a data communication protocol used to connect the device to supervisory control and data acquisition (SCADA) systems.

It supports up to 5 simultaneous connections and allows up to 5 Modbus-TCP clients (masters) to monitor it at the same time. Connections can be made via Ethernet interface and Wi-Fi connection, respecting the maximum limit of 5 simultaneous connections.

It is also possible to configure and collect data from **AirGate Air+** via TCP/IP network. To do this, you must use **NXperience** (see [CONFIGURATION SOFTWARE](#)).

### 9.1 COMMAND

You only have access to the Read Holding Registers command (0x03), which allows 1 to 125 registers to be read consecutively.

The accessible registers are described in the tables below.

### 9.2 ADDRESS (UNIT ID)

**AirGate Air+** does not validate the address field (also called **Unit ID**) of the Modbus-TCP package. As such, it will respond to Modbus-TCP packets destined for its configured port, regardless of the value of this field and without forwarding them to the linked **RHTs**.

The port number used will be the same on both the Ethernet and Wi-Fi interfaces. To set the Modbus-TCP port, see the [COMMUNICATION](#) section of [CONFIGURATION SOFTWARE](#).

### 9.3 TABLE OF REGISTERS

ADDRESS	MNEMONIC	DESCRIPTION	INFORMATION
0	SERIAL_NUMBER_H	Serial number of the device (Higher part).	
1	SERIAL_NUMBER_L	Serial number of the device (Lower part).	
2	PRODUCT_CODE	Device code.	
3	FIRMWARE_VERSION	Firmware version.	Unit with 2 decimal places.
Reserved area			
7	MAC_ADDR_ETH_0_1	MAC Address Ethernet.	(XX:XX:00:00:00:00)
8	MAC_ADDR_ETH_2_3	MAC Address Ethernet.	(00:00:XX:XX:00:00)
9	MAC_ADDR_ETH_4_5	MAC Address Ethernet.	(00:00:00:00:XX:XX)
10	MAC_ADDR_WI-FI_0_1	MAC Address Wi-Fi.	(XX:XX:00:00:00:00)
11	MAC_ADDR_WI-FI_2_3	MAC Address Wi-Fi.	(00:00:XX:XX:00:00)
12	MAC_ADDR_WI-FI_4_5	MAC Address Wi-Fi.	(00:00:00:00:XX:XX)
13	ETH_IP_ADDR_0_1	Address of the device on the Ethernet network (Higher part).	XXX.XXX.000.000
14	ETH_IP_ADDR_2_3	Address of the device on the Ethernet network (Lower part).	000.000.XXX.XXX
15	ETH_MASK_ADDR_0_1	Network mask on the Ethernet network (Higher part).	XXX.XXX.000.000
16	ETH_MASK_ADDR_2_3	Network mask on the Ethernet network (Upper part).	000.000.XXX.XXX
17	ETH_GATEWAY_ADDR_0_1	Gateway address of the Ethernet network (Higher part).	XXX.XXX.000.000
18	ETH_GATEWAY_ADDR_2_3	Gateway address of the Ethernet network (Lower part).	000.000.XXX.XXX
Reserved area			
23	WI-FI_IP_ADDR_0_1	Address of the device on the Wi-Fi network (Higher part).	XXX.XXX.000.000
24	WI-FI_IP_ADDR_2_3	Address of the device on the Wi-Fi network (Lower part).	000.000.XXX.XXX
25	WI-FI_MASK_ADDR_0_1	Netmask on the Wi-Fi network (Higher part).	XXX.XXX.000.000
26	WI-FI_MASK_ADDR_2_3	Netmask on the Wi-Fi network (Lower part).	000.000.XXX.XXX
27	WI-FI_GATEWAY_ADDR_0_1	Gateway address of the Wi-Fi network (Higher part).	XXX.XXX.000.000

ADDRESS	MNEMONIC	DESCRIPTION	INFORMATION
28	WI-FI_GATEWAY_ADDR_2_3	Gateway address of the Wi-Fi network (Lower part).	000.000.XXX.XXX
29	ETH_CONN_STATE	Ethernet communication status.	0 → Disabled interface. 1 → Disconnected interface. 2 → Connected interface. Greater than or equal to 5 → Generic connection error.
30	WI-FI_CONN_STATE	Wi-Fi communication status.	0 → Disabled interface. 1 → Disconnected interface. 2 → Connected interface. 3 → Wi-Fi network (SSID) not found. 4 → Incorrect Wi-Fi network password. Greater than or equal to 5 → Generic connection error.
31	WI-FI_RSSI	Signal quality between <b>AirGate Air+</b> and Wi-Fi Router.	Unit with signal in dBm.
32	WI-FI_AP_STATE	Status of the Wi-Fi access point.	0 → Disabled. 1 → Enabled.
33	WI-FI_AP_CLIENTS	Number of clients connected to the Wi-Fi access point generated by the device.	
Reserved area			
40	MODBUS_TCP_CONNECTIONS	Number of active Modbus-TCP connections.	
41	MQTT_CONN_STATE	Communication status with the MQTT Broker:	0 → Disabled protocol. 1 → Waiting for network connection (Wi-Fi or Ethernet). 2 → Connecting to the Broker. 3 → Connected to the Broker. 4 → Error: Socket opening. 5 → Error: Protocol configuration not supported. 6 → Error: Duplicate identifier in the MQTT Broker list. 7 → Error: Server unavailable. 8 → Error: Unknown user. 9 → Error: User not authorized.
Reserved area			
44	ALARM_TEMP_MIN_STATUS_HIGH	Low temperature alarm status (Higher part).	Each position of the bitarray indicates the status of the <b>RHT</b> slot: Bit 0 → <b>RHT Air+</b> : Slot 1 Bit 1 → <b>RHT Air+</b> : Slot 2 Bit 2 → <b>RHT Air+</b> : Slot 3 (...) Bit 29 → <b>RHT Air+</b> : Slot 30 Bit 30 → <b>RHT Air+</b> : Slot 31 Bit 31 → <b>RHT Air+</b> : Slot 32
45	ALARM_TEMP_MIN_STATUS_LOW	Low temperature alarm status (Lower part).	
46	ALARM_TEMP_MAX_STATUS_HIGH	High temperature alarm status (Higher part).	
47	ALARM_TEMP_MAX_STATUS_LOW	High temperature alarm status (Lower part).	
48	ALARM_HUMID_MIN_STATUS_HIGH	Low humidity alarm status (Higher part).	
49	ALARM_HUMID_MIN_STATUS_LOW	Low humidity alarm status (Lower part).	
50	ALARM_HUMID_MAX_STATUS_HIGH	High humidity alarm status (Higher part).	
51	ALARM_HUMID_MAX_STATUS_LOW	High humidity alarm status (Lower part).	
52	ALARM_CALCVAR_MIN_STATUS_HIGH	Low alarm status of the calculated variable (Higher part).	
53	ALARM_CALCVAR_MIN_STATUS_LOW	Status of the calculated variable low alarm (Lower part).	
54	ALARM_CALCVAR_MAX_STATUS_HIGH	High alarm status of the calculated variable (Higher part).	

ADDRESS	MNEMONIC	DESCRIPTION	INFORMATION
55	ALARM_CALCVAR_MAX_STATUS_LOW	High alarm status of the calculated variable (Lower part).	
56	ALARM_LOW_BAT_STATUS_HIGH	Low battery alarm status of the RHT (Higher part).	
57	ALARM_LOW_BAT_STATUS_LOW	Low battery alarm status of the RHT (Lower part).	
58	ALARM_ABSENT_STATUS_HIGH	Disconnect alarm status of the RHT (Higher part).	
59	ALARM_ABSENT_STATUS_LOW	Disconnect alarm status of the RHT (Lower part).	
Reserved area			
98	Registers for RHT Air+ in Slot 1.		
148	Registers for RHT Air+ in Slot 2.		
198	Registers for RHT Air+ in Slot 3.		
248	Registers for RHT Air+ in Slot 4.		
298	Registers for RHT Air+ in Slot 5.		
348	Registers for RHT Air+ in Slot 6.		
398	Registers for RHT Air+ in Slot 7.		
448	Registers for RHT Air+ in Slot 8.		
498	Registers for RHT Air+ in Slot 9.		
548	Registers for RHT Air+ in Slot 10.		
598	Registers for RHT Air+ in Slot 11.		
648	Registers for RHT Air+ in Slot 12.		
698	Registers for RHT Air+ in Slot 13.		
748	Registers for RHT Air+ in Slot 14.		
798	Registers for RHT Air+ in Slot 15.		
848	Registers for RHT Air+ in Slot 16.		
898	Registers for RHT Air+ in Slot 17.		
948	Registers for RHT Air+ in Slot 18.		
998	Registers for RHT Air+ in Slot 19.		
1048	Registers for RHT Air+ in Slot 20.		
1098	Registers for RHT Air+ in Slot 21.		
1148	Registers for RHT Air+ in Slot 22.		
1198	Registers for RHT Air+ in Slot 23.		
1248	Registers for RHT Air+ in Slot 24.		
1298	Registers for RHT Air+ in Slot 25.		
1348	Registers for RHT Air+ in Slot 26.		
1398	Registers for RHT Air+ in Slot 27.		
1448	Registers for RHT Air+ in Slot 28.		
1498	Registers for RHT Air+ in Slot 29.		
1548	Registers for RHT Air+ in Slot 30.		
1598	Registers for RHT Air+ in Slot 31.		
1648	Registers for RHT Air+ in Slot 32.		

Table 8

## 9.4 RHT AIR+: SLOT REGISTERS

OFFSET	MNEMONIC	DESCRIPTION	INFORMATION
0	RHT_ADDR_NUMBER_HIGH	Serial number of the <b>RHT Air+</b> in this slot (Higher part).	Unsigned 32-bit number.
1	RHT_ADDR_NUMBER_LOW	Serial number of the <b>RHT Air+</b> in this slot (Lower part).	
2	LAST_CONN_TS_HIGH	Date of last communication with the <b>RHT Air+</b> from the Slot (Higher part).	Unix Timestamp; UTC
3	LAST_CONN_TS_LOW	Date of last communication with the <b>RHT Air+</b> from the Slot (Lower part).	Unix Timestamp; UTC
4	LAST_DATA_TS_HIGH	Date of the last data received from the <b>RHT Air+</b> in the Slot (Higher part).	Unix Timestamp; UTC
5	LAST_DATA_TS_LOW	Date of the last data received from the <b>RHT Air+</b> in the Slot (Lower part).	Unix Timestamp; UTC
6	LAST_DATA_TEMP	Value of the last temperature data received from the <b>RHT Air+</b> in the Slot.	Unit with sign in Celsius to 2 decimal places.
7	LAST_DATA_HUMID	Value of the last humidity data received from the <b>RHT Air+</b> in the Slot.	Signed value with 2 decimal places.*
8	HOURLMETER	Operating time (in hours) from the <b>RHT Air+</b> in the Slot.	
9	BATTERY_LEVEL	Battery level from the <b>RHT Air+</b> in the Slot.	
10	TX_POWER	Transmission power from the <b>RHT Air+</b> in the Slot.	Unit with signal in dBm.
11	RSSI	Quality signal from the <b>RHT Air+</b> in the Slot.	Unit with signal in dBm.
12	TX_MSG_COUNTER_HIGH	Counter of messages transmitted by the <b>RHT Air+</b> from the Slot (Higher part).	
13	TX_MSG_COUNTER_LOW	Counter of messages transmitted by the <b>RHT Air+</b> from the Slot (Lower part).	
14	RX_MSG_COUNTER_HIGH	Counter of messages received by the <b>RHT Air+</b> from the Slot (Higher part).	
15	RX_MSG_COUNTER_LOW	Counter of messages received by the <b>RHT Air+</b> from the Slot (Lower part).	
16	DIAG_PROBE_SN_HIGH	Serial number of the humidity and temperature sensor tip connected to the <b>RHT Air+</b> from the Slot (Lower part).	
17	DIAG_PROBE_SN_LOW	Serial number of the humidity and temperature sensor tip connected to the <b>RHT Air+</b> from the Slot (Lower part).	
18	DIAG_FW_VER	Firmware version of the <b>RHT Air+</b> from the Slot.	Unsigned value with 2 decimal places.
19	LAST_DATA_TEMP_FLOAT_HIGH	Value of the last temperature data received from the <b>RHT Air+</b> in the Slot (Higher part).	Formatted for float.*
20	LAST_DATA_TEMP_FLOAT_LOW	Value of the last temperature data received from the <b>RHT Air+</b> in the Slot (Lower part).	Formatted for float.*
21	LAST_DATA_HUMID_FLOAT_HIGH	Value of the last humidity data received from the <b>RHT Air+</b> in the Slot (Higher part).	Formatted for float.*
22	LAST_DATA_HUMID_FLOAT_LOW	Value of the last humidity data received from the <b>RHT Air+</b> in the Slot (Lower part).	Formatted for float.*
23	LAST_DATA_CALC_FLOAT_HIGH	Value calculated, according to the selection of the psychrometric quantity, based on the latest temperature and humidity values received from the <b>RHT Air+</b> in the Slot (Higher part).	Formatted for float.*
24	LAST_DATA_CALC_FLOAT_LOW	Value calculated, according to the selection of the psychrometric quantity, based on the latest temperature and humidity values received from the <b>RHT Air+</b> in the Slot (Lower part).	Formatted for float.*
25	NUM_OF_RECORDS	Number of logs stored in the area of the <b>RHT Air+</b> in the Slot.	
26	FIRST_RECORD_TS_HIGH	Date of the first log stored in the area of the <b>RHT Air+</b> in the Slot (Higher part).	Unix Timestamp; UTC

OFFSET	MNEMONIC	DESCRIPTION	INFORMATION
27	FIRST_RECORD_TS_LOW	Date of the first log stored in the area of the <b>RHT Air+</b> in the Slot (Lower part).	Unix Timestamp; UTC
28	LAST_RECORD_TS_HIGH	Date of the last log stored in the area of the <b>RHT Air+</b> in the Slot (Higher part).	Unix Timestamp; UTC
29	LAST_RECORD_TS_LOW	Date of the last log stored in the area of the <b>RHT Air+</b> in the Slot (Lower part).	Unix Timestamp; UTC
30	LAST_PUB_SMTP_TS_HIGH	Date of the last log in the <b>RHT Air+</b> of the Slot in which the alarm was evaluated for sending an email (Higher part).	Unix Timestamp; UTC
31	LAST_PUB_SMTP_TS_LOW	Date of the last log in the <b>RHT Air+</b> of the Slot in which the alarm was evaluated for sending an email (Lower part).	Unix Timestamp; UTC
32	LAST_PUB_MQTT_TS_HIGH	Date of the last log published via MQTT with data from the <b>RHT Air+</b> in the Slot (Higher part).	Unix Timestamp; UTC
33	LAST_PUB_MQTT_TS_LOW	Date of the last log published via MQTT with data from the <b>RHT Air+</b> in the Slot (Lower part).	Unix Timestamp; UTC
34	CONN_REQUEST_COUNTER	Connection request counter for the <b>RHT Air+</b> of the slot with <b>AirGate Air+</b> .	Unsigned value.
35	RHT_BATTERY_VOLTAGE	Battery voltage value of the <b>RHT Air+</b> of the slot received by <b>AirGate Air+</b> during diagnostic.	Unsigned value with 1 decimal place.
36	Area reserved for manufacturer diagnostic data.		
37			
38			
39	Reserved area.		
40 to 48			
49			

Table 9

\* A return of **-32000** indicates a problem with the tip of the **RHT Air+** temperature and humidity sensor. If the disconnection alarm is enabled (see [ALARMS](#) section in [CONFIGURATION SOFTWARE](#)) and the **RHT Air+** has not received data within the configured alarm interval, the registers will return the value **-22000**.

### 10.1 RHT AIR+: DATE/TIME

RHT Air+ will only log data if the date and time have been set. However, when paired with an **AirGate Air+**, your time will be synchronized with the same time as within the **Air+** network.

### 10.2 AIRGATE AIR+: DATE/TIME

The date and time of **AirGate Air+** are synchronized automatically via an NTP server (see [CONFIGURATION SOFTWARE](#)). If date/time synchronization is disabled, the device will use the date/time configured by the user and will not correct it until a new configuration is applied. This way, if the **AirGate Air+** shuts down during a power outage, it will not provide a valid date/time to the paired **RHTs**, preventing synchronization between the **RHTs**.

When automatic date/time synchronization is enabled, **AirGate Air+** will automatically keep the **RHT Air+** synchronized, so as not to hinder data recording and publishing after power is restored.

## 11.1 NXPERIENCE SOFTWARE

**NXperience** allows you to configure and analyze data from **AirGate Air+** and **RHT Air+**. The devices can communicate with the software via the USB interface connected to the computer being used or, for **AirGate Air+**, also via Modbus-TCP protocol.

The software and manual can be downloaded for free from the Downloads area of our website: [www.novusautomation.com](http://www.novusautomation.com).

	<ol style="list-style-type: none"> <li>1. This manual describes the <b>CONFIGURATION</b> and <b>DIAGNOSTICS</b> features. For more information (such as the <b>DOWNLOAD</b> process and information on <b>PREFERENCES</b> or <b>Standard</b> or <b>Validated usage modes</b>, for example), see the <b>NXperience</b> operations manual.</li> <li>2. <b>AirGate Air+</b> and <b>RHT Air+</b> are only compatible with <b>NXperience</b> software. It is not possible to use proprietary software to configure, collect data or perform diagnostics on the devices.</li> </ol>
---	---

Once initialized, **NXperience** will display the following screen and buttons:

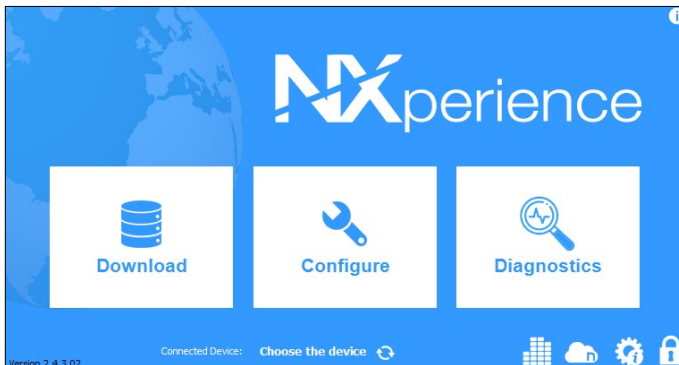









Figure 21

-  : Allows you to collect data from the selected device.
-  : Allows you to configure the connected device.
-  : Allows you to perform diagnostics on the connected device.
-  : Allows you to supervise the connected device. **AirGate Air+** and **RHT Air+** are not compatible with this feature.
-  : Allows you to open the **NOVUS Cloud** manager.
-  : Allows you to change the software preferences.
-  : Allows you to access the **NXperience Trust** management screen.
-  : Allows you to access the **NXperience** manual.

## 11.2 USING NXPERIENCE TO CONFIGURE YOUR AIRGATE AIR+

Below is a description of each of the possible configuration parameters, grouped by section.

### 11.2.1 GENERAL PARAMETERS

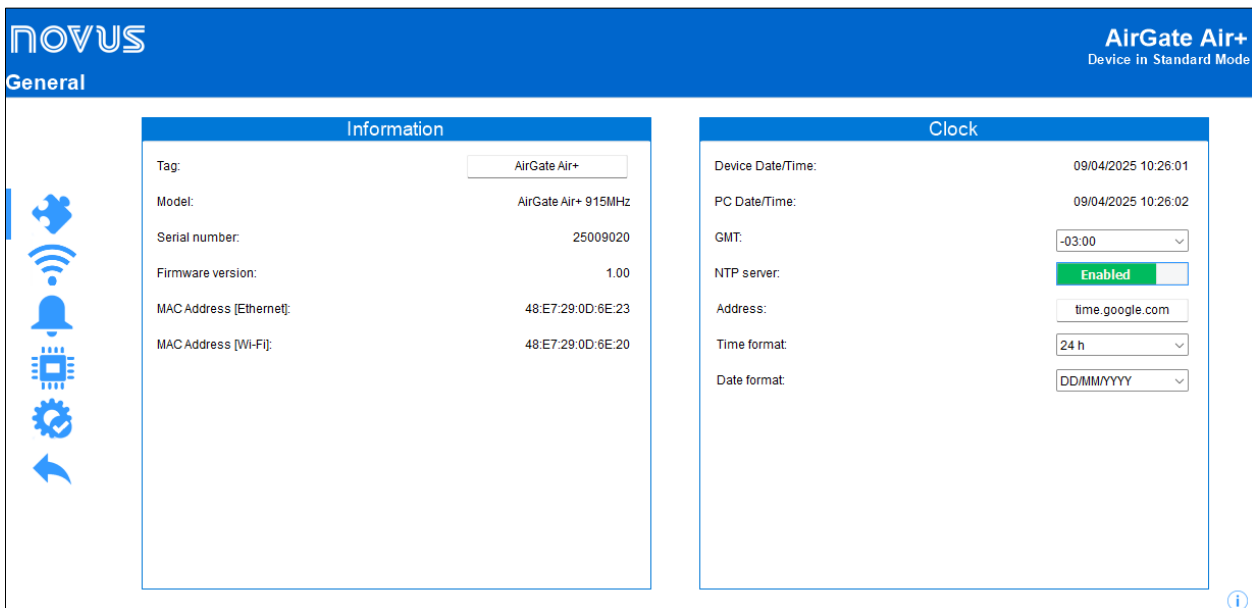

Figure 22

#### INFORMATION

- **Tag:** Allows you to define an identification tag for the device. The field allows up to 20 alphanumeric characters.
- **Model:** Displays the model of the device.
- **Serial number:** Displays the unique identification number of the device. The serial number is also used to register the device in **NOVUS Cloud**.

- **Firmware version:** Displays the firmware version of the device.
- **MAC address [Ethernet]:** Displays the MAC address of the Ethernet interface.
- **MAC address [Wi-Fi]:** Displays the MAC address of the Wi-Fi interface.

## MODBUS-TCP

- **Enable protocol:** Allows you to enable the Modbus-TCP protocol.
- **Service port:** Allows you to define the TCP port on which the service will be available.

## CLOCK

- **Device Date/Time:** Displays the date and time set in the memory of the device.
- **PC Date/Time:** Displays the date and time of the Windows system, which will be used by **NXperience** to set the device's clock at the time the configuration is sent.
- **GMT:** Allows you to set the GMT of the location where the device will be used (preferably during the first use).
- **NTP server:** Once enabled, this parameter allows the automatic synchronization of the clock via NTP server.
- **Address:** Allows you to enter the address of the NTP server to be used for automatic clock synchronization.
- **Time format:** Allows you to define the format to be used to display the time.
- **Date format:** Allows you to define the format to be used to display the date.

## 11.2.2 COMMUNICATION

This screen is divided into the following tabs: **Connections**, **MQTT**, and **SMTP**.

### CONNECTIONS

The screenshot shows the 'Communication' settings for the NOVUS AirGate Air+ device in Standard Mode. The 'Connections' tab is active, displaying three main configuration panels: Wi-Fi, Ethernet, and Modbus-TCP. The Wi-Fi panel shows 'Enable Wi-Fi' as 'Enabled', 'Access Point SSID' as 'NOVUS', 'Access Point password' as masked, 'Address acquisition method' as 'DHCP', and IP-related fields (IP Address, Subnet mask, Default Gateway, DNS server) all set to 0.0.0.0. The Ethernet panel shows 'Enable Ethernet' as 'Enabled', 'Address acquisition method' as 'DHCP', and IP-related fields all set to 0.0.0.0. The Modbus-TCP panel shows 'Enable protocol' as 'Enabled' and 'Service port' as 502. There is also an 'Access Point' section with 'Enable Access Point' set to 'Enabled by button', 'SSID' as 'NOVUS\_25009017', and 'Password' as masked. A navigation sidebar on the left contains icons for connections, notifications, device status, settings, and back.

Figure 23

### WI-FI

- **Enable Wi-Fi:** Allows you to enable the Wi-Fi interface.
- **SSID:** Allows you to enter the name of the Wi-Fi network to which your **AirGate Air+** will try to connect. The field allows up to 32 alphanumeric characters.
- **Password:** Allows you to enter the password for the Wi-Fi network to which your **AirGate Air+** will try to connect. The field allows up to 64 alphanumeric characters.
- **Address acquisition method:** If this interface is enabled, you can define how **AirGate Air+** will try to acquire an IP address:
  - **DHCP (Dynamic Host Configuration Protocol):** Allows the network server to assign an IP to the device.
  - **Static:** Allows you to define the IP address, subnet mask and default Gateway for the connection. In this case, you also need to define the DNS (Domain Name System) server.  
By default, the device is set to **DHCP**.
- **IP address:** Allows you to enter the IP address to be used. This parameter refers to the identification of the device on a local or public network. Every computer or device on the Internet or on an internal network has a unique IP address.  
This is a mandatory field when the **Address acquisition method** parameter is set to **Static**.
- **Subnet Mask:** Allows you to set the netmask to be used. This parameter allows you to divide a specific network into smaller subnets, making the use of a given IP address space more effective.

This is a mandatory field when the **Address acquisition method** parameter is set to **Static**.

- **Default Gateway:** Allows you to set the Gateway to be used. This parameter refers to the address of the device on the network that connects it to the Internet.

This is a mandatory field when **Address acquisition method** mode is set to **Static**.

- **DNS server:** Allows you to set the DNS server to be used. This parameter refers to a hierarchical and distributed name management system for computers, services or any resource connected to the Internet or a private network.

This is an optional field when **Address acquisition method** mode is set to **Static**.

## ETHERNET

- **Enable Ethernet:** Allows you to enable the Ethernet communication interface through RJ45 cabled network.
- **Address acquisition method:** Allows you to define how your **AirGate Air+** will try to acquire an IP address:
  - **DHCP (Dynamic Host Configuration Protocol):** Allows the network server to assign an IP to the device.
  - **Static:** Allows you to define the IP address, subnet mask, and default Gateway for the connection. In this case, you also need to define the DNS (Domain Name System) server.

By default, the device is set to **DHCP**.

- **IP address:** Allows you to enter the IP address to be used. This parameter refers to the identification of the device on a local or public network. Every computer or device on the Internet or on an internal network has a unique IP address.

This is a mandatory field when the **Address acquisition method** parameter is set to **Static**.

- **Subnet Mask:** Allows you to set the netmask to be used. This parameter allows you to divide a specific network into smaller subnets, making the use of a given IP address space more effective.

This is a mandatory field when the **Address acquisition method** parameter is set to **Static**.

- **Default Gateway:** Allows you to set the Gateway to be used. This parameter refers to the address of the device on the network that connects it to the Internet.

This is a mandatory field when the **Address acquisition method** parameter is set to **Static**.

- **DNS server:** Allows you to set the DNS server to be used. This parameter refers to a hierarchical and distributed name management system for computers, services or any resource connected to the Internet or a private network.

This is a mandatory field when the **Address acquisition method** parameter is set to **Static**.

## MODBUS-TCP

- **Enable Protocol:** Enables the Modbus-TCP service.
- **Service Port:** Allows you to define the TCP port on which the service will be available.

## ACCESS POINT

- **Enable access point:** If selected, allows the **AirGate Air+** to generate a Wi-Fi network, which will allow other devices to connect to it.
  - **Disabled:** **AirGate Air+** will not provide a Wi-Fi network.
  - **Enabled by button:** After pressing the only key on the **AirGate Air+**, the device will provide a Wi-Fi network. If no device is connected within 3 minutes, the Wi-Fi network will be deactivated.
  - **Always enabled:** The Wi-Fi network generated by **AirGate Air+** will always be available for connection.
- **SSID:** Allows you to enter the name of the Wi-Fi network provided by **AirGate Air+**. By default, the field will be filled with the value based on the serial number (e.g.: NOVUS\_12345678). The field allows up to 32 alphanumeric characters.
- **Password:** Allows you to enter the password for the Wi-Fi network provided by **AirGate Air+**. By default, the field will be filled with the serial number. The field allows up to 64 alphanumeric characters and requires at least 8 characters.

The screenshot shows the 'Communication' settings for a NOVUS AirGate Air+ device in Standard Mode. The 'MQTT' tab is active, and the 'Enable MQTT' toggle is turned on. The configuration includes fields for Device ID (airgate), Broker user (User), Broker password (masked), Broker URL or IP, Publisher Topic (novus/airgate/rht), Alarm Topic (novus/airgate/alarm), and Security (TLS V1.2 - Self Signed). There are also dropdown menus for Cloud (General), Service port (8883), QoS (QoS 1), and Retain data (No). Search buttons are provided for CA Certificate, Client Certificate, and Private key.

Figure 24

- **Enable MQTT:** Enables data to be sent via the MQTT protocol.
- **Cloud:** Allows you to select the platform to be used when connecting to the MQTT Broker: Generic platform (General), **NOVUS Cloud**, Amazon AWS, or Google Cloud. According to the option chosen, the other parameters will be adjusted to meet the specific requirements of the platform. To customize all the parameters, select the **General** option, which refers to the generic platform.
- **Device ID:** Allows you to define an ID for the device.
- **Broker User:** Allows you to enter the name of the user registered with the Broker. The field allows up to 64 alphanumeric characters. If the field is empty, the connection will be made in anonymous mode.
- **Broker Password:** Allows you to enter the password of the user registered with the Broker. The field allows up to 64 alphanumeric characters. If the field is empty, the connection will be made in anonymous mode.
- **Service Port:** Allows you to define the port number used to connect to the Broker.
- **QoS:** Allows you to select the quality-of-service level used when sending MQTT messages.
- **Retain Data:** Allows you to define whether data should be retained in the cloud. Not all platforms support this feature.
- **Broker URL or IP:** Allows you to enter the address of the Broker, which can be a URL or an IP. The field allows up to 60 characters.
- **Device ID:** Allows you to configure an ID for the device.
- **Publication topic:** Allows the header of periodical publications to be defined, according to the data received by the linked **RHT Air+**. When publishing, the name of the topic will be linked to the Tag of the **RHT Air+** that originated the information (e.g. novus/airgate/rht\_tag).
- **Alarm topic:** Allows you to define the header of the alarm publications related to the linked **RHT Air+**. When publishing, the name of the topic will be linked to the Tag of the **RHT Air+** that originated the information (e.g. novus/airgate/rht\_tag).
- **Security:** Allows you to define the protocol and data encryption for secure communication with the MQTT Broker.
  - **None:** No security measures will be used.
  - **TLS V1.2 – Server Signed:** If this option is selected, communication with the Broker will use the Transport Layer Security (TLS) 1.2 protocol. Security is achieved by negotiating the device's private key with the authentication of the certificate being generated by the server.
  - **TLS V1.2 – CA Only:** If this option is selected, communication with the Broker will use the Transport Layer Security (TLS) 1.2 protocol, which requires a TLS certificate recognized by a certification authority (CA) to ensure data privacy and integrity.
  - **TLS V1.2 – Self Signed:** If this option is selected, communication with the Broker will use the Transport Layer Security (TLS) 1.2 protocol, which, in addition to the TLS certificate recognized by a certification authority (CA), also requires authentication of the client's certificate and private key to ensure data privacy and integrity.

CA certificate, client certificate and private key files are only accepted in .pem and .der formats.

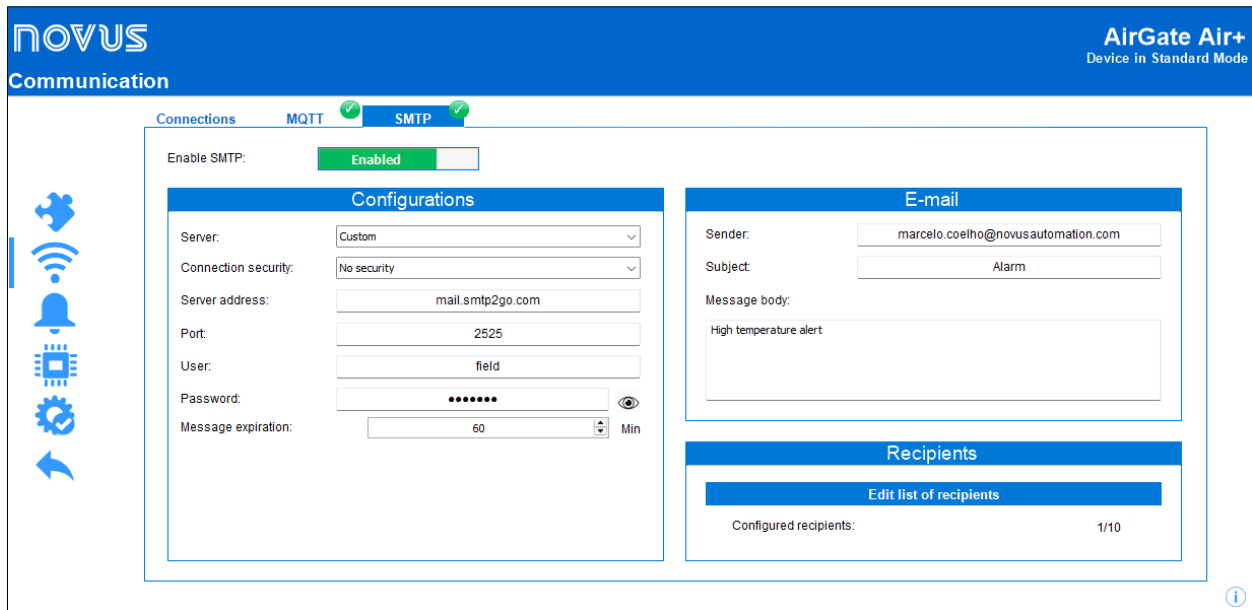

Figure 25

- **Enable SMTP:** Allows you to enable the email sending functions to signal alarms (see [SMTP PROTOCOL](#)).

## SETTINGS

This allows you to enter the data required to authenticate the user on the selected server.

- **Default server:** Allows you to select the email server to be used.
- **Connection security:** Allows you to select the connection security mode, which can be without security or with TLS protocol.
- **Server address:** Allows you to enter the address of the email server to be used.
- **Port:** Allows you to enter the connection port to be used by the selected email server.
- **User:** Allows you to enter the username of the email to be used.
- **Password:** Allows you to enter the password of the email to be used.
- **Message expiration:** Allows you to define how long ago the device will evaluate the logs to send an alarm email.

This parameter will also prevent you from receiving emails with alarm warnings registered outside the period of interest. You can set a minimum limit of 1 minute or a maximum limit of 200 hours.

## EMAIL

It allows you to enter the email address of the message sender's, a title and the message that will be sent along with the data collected on the previously configured alarm.

- **Sender:** Allows you to enter the email address of the sender.
- **Title:** Allows you to enter a title for the email.
- **Common part of the message:** Allows you to enter the message that will be sent along with the data collected on the previously configured alarm. The common part of the message, as its name suggests, will be identical for all emails.

## RECIPIENTS

You can create and edit the list of recipients. You can register up to 10 emails.

### 11.2.3 ALARMS

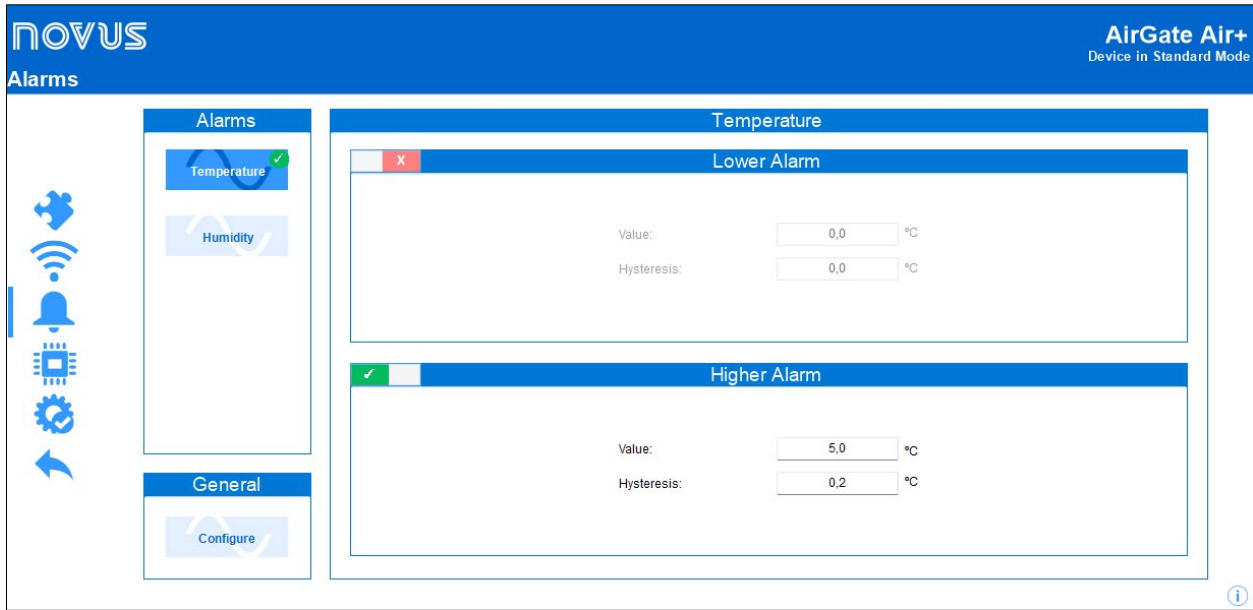

Figure 26

For each of the variables measured, you can enable a minimum and/or maximum alarm.

- **Setpoint:** Allows you to set the value to be exceeded for the variable to satisfy the alarm situation.
- **Hysteresis:** Allows you to set the barrier to be crossed for the variable to exit the alarm situation.

**NXperience alarm reports:**

In the **DOWNLOAD** tab of NXperience (for more information, see the NXperience manual), you can collect data from AirGate Air+ and use it to create reports on the configured alarms.

AirGate Air+ does not erase the log memory. When changing an alarm configuration and then collecting and creating an alarm report, this report may show alarm events that were mapped by the software but did not occur on the device (and vice versa), as the alarms were configured after the logs were recorded in memory.

#### GENERAL

When clicking on the **Configure** button, it is possible to configure the alarm functions:

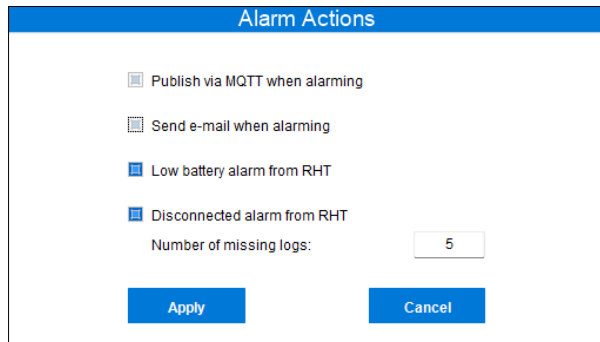

Figure 27

- **Publish via MQTT when alarming:** Allows data to be published via MQTT when the device is in alarm. To do this, the MQTT protocol must be enabled and configured (see [COMMUNICATION](#)).
- **Send email when alarming:** Allows an email to be sent to the configured contacts when the device is in alarm. To do this, the SMTP protocol must be enabled and configured, and the user must have registered recipients (see [COMMUNICATION](#)).
- **Low Battery alarm from RHT:** Allows signals to be sent when the RHT Air+ battery is low.
- **Disconnected alarm from RHT:** Allows signals to be sent when an RHT Air+ is disconnected.

## 11.2.4 AIR+ NETWORK

This screen is divided into the following tabs: **Slots** and **General**.

### SLOTS

This screen allows you to manage the devices linked to your **AirGate Air+**. In the **Commissioned** section, you'll find the **RHT Air+** linked to the **AirGate Air+**. You can browse through the list and view some specific settings for the **RHT Air+** in the slot. In the **Waiting List** section, you will find **RHT Air+** that are available but have not yet been linked to **AirGate Air+**.

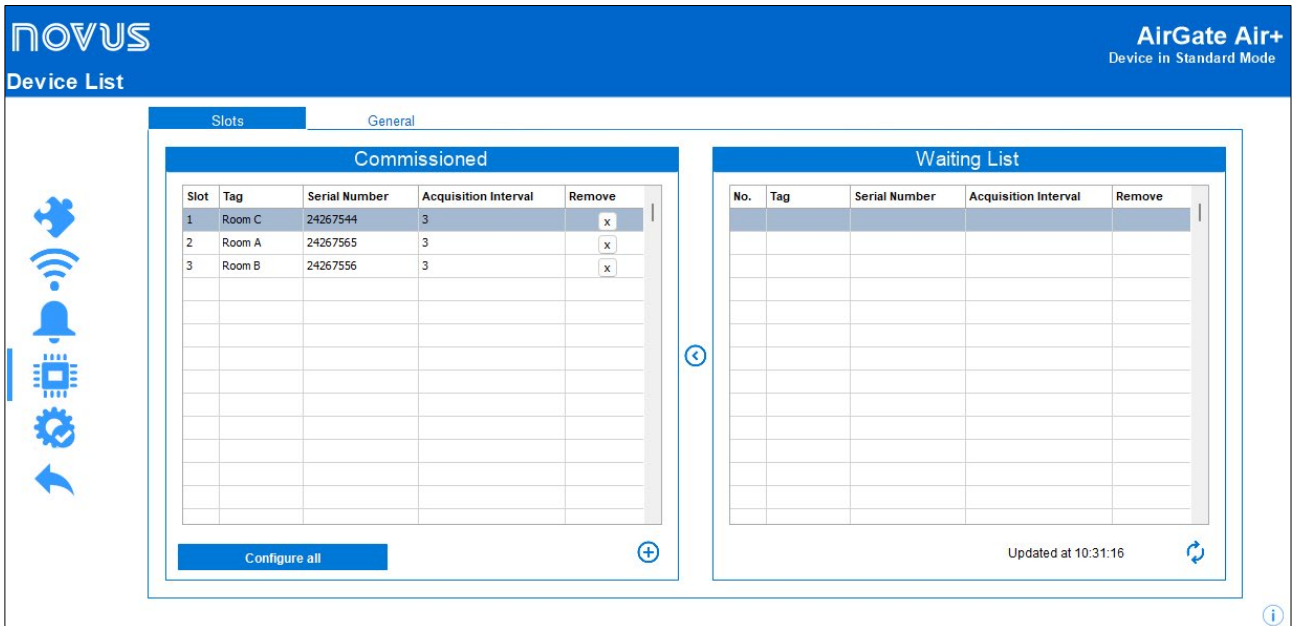

Figure 28

- **Tag:** Displays the tag configured for the device in question. By double-clicking on the line of the desired device, you can edit it. This field allows up to 8 alphanumeric characters.

The Tag will also be used by the MQTT and STMP services to identify the **RHT Air+** that is generating information.

If no Tag has been configured at this point, the device will use the Tag defined in the **Device Tag** parameter, displayed in the **General Parameters** tab of **RHT Air+** (see the [GENERAL PARAMETERS](#) subsection of [USING NXPERIENCE TO CONFIGURE YOUR RHT AIR+](#)).



Although the **Air+ Network** tab allows you to edit some details about each device, its function is to display and manage the commissioning of the **Air+ RHTs** configured in the [USING NXPERIENCE TO CONFIGURE YOUR RHT AIR+](#) section. Before linking your **RHT Air+** to an **AirGate Air+**, it is recommended to configure it according to your needs.

- **Serial number:** Displays the unique identifier of the **RHT Air+**, value set during manufacture.
- **Acquisition interval:** Displays the acquisition interval configured for the device in question. By double-clicking on the line of the desired device, you can edit it.  
You can set a unique value for the interval of logs from the **RHT Air+** linked to the slot. If no value has been set at this point, the logs received by **RHT Air+** from that slot will be controlled by the configured acquisition interval. This interval can be set in the **General** tab of **AirGate Air+**.
- **Remove:** Allows you to remove the selected **RHT Air+** from the **AirGate Air+** provisioning list.

By clicking the button, you can manually add an **RHT Air+** to the list of commissioned devices.

By clicking on the button, you can update the **Waiting List**.

By clicking the and buttons, you can move a device from the **Commissioned** list to the **Waiting List**.



It is recommended to use a log interval of 5 minutes or more.

For best performance when using a shorter logging interval, consider the maximum number of devices on the network in the ratio of 5 devices for each minute of logging interval.

When setting the **Acquisition interval** parameter to 2 minutes, for example, consider using a maximum of 10 **RHTs**.

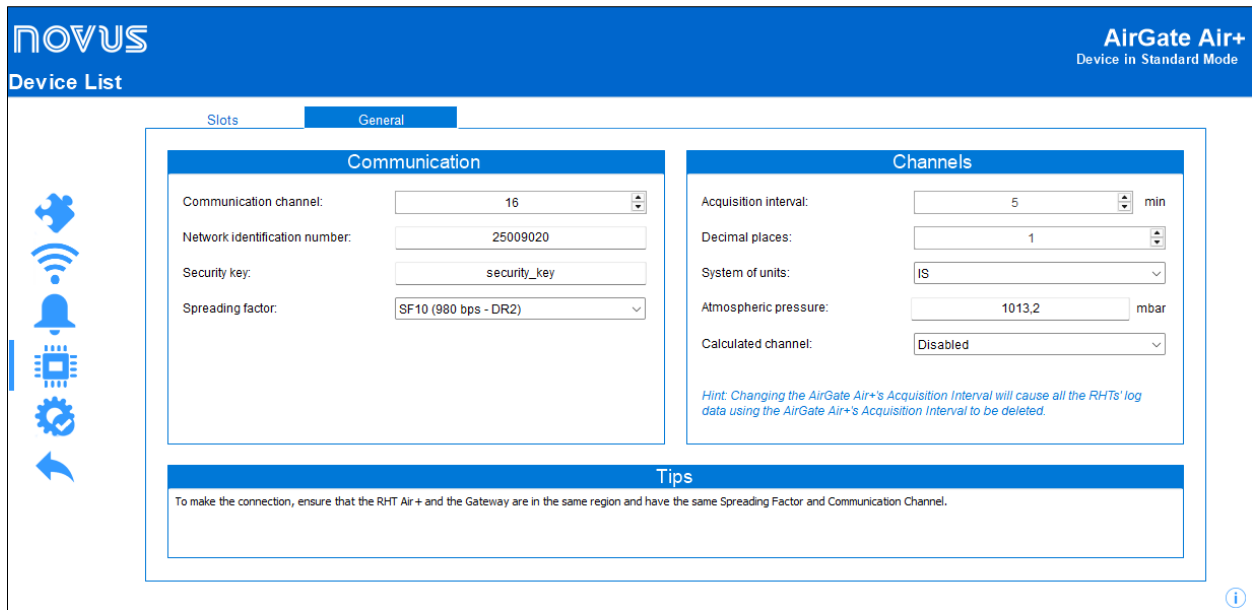

Figure 29

**COMMUNICATION**

- **Communication channel:** Allows you to set a value for the communication channel. This parameter helps to resolve network conflicts. If there is another **AirGate Air+** in the coverage area, it is recommended that they operate on separate channels so that there are no communication failures between **AirGate Air+** and **RHT Air+**.
- **Network identification number:** Allows you to set an identification number for the network. If you don't set any number, **AirGate Air+** will use its serial number. The field allows up to 8 characters.
- **Security key:** Allows you to enter a security key to protect private network communication. This field requires 16 alphanumeric characters. This key will be used during communication between the **AirGate Air+** and the **RHTs**. After the connection, the data messages will be encrypted with the configured security key.

**Filling in the security key is mandatory and required when opening the configuration of any device.**  
 To navigate through the configuration screens, you must first configure the security key.

- **Spreading factor:** Characteristic parameter of LoRa communication, it defines the robustness of the **Air+** network communication. The side effect of this parameter is high energy consumption as the level of communication reliability increases.
- The propagation factors allowed are SF7 to SF11, the latter guaranteeing the best network robustness but with the highest energy consumption. In most cases, it is recommended to use SF10.

**CHANNELS**

- **Acquisition interval:** Allows you to set a range of logs to be shared by all **RHT Air+** linked to **AirGate Air+**.

**It is recommended to use a log interval of 5 minutes or more.**  
 For best performance when using a shorter logging interval, consider the maximum number of devices on the network in the ratio of 5 devices for each minute of logging interval.  
 When setting the **Acquisition Interval** parameter to 2 minutes, for example, consider using a maximum of 10 **RHTs**.

- **Decimal places:** Allows you to set how the humidity, temperature, and calculated variable values will be displayed.
- **System of units:** Allows you to set the International System or the English System of measurements.

Options for calculated variables, according to the International System or the English System of measurement:

	SI	US
Temperature	°C	°F
Relative humidity	% RH	% RH
Dew point temperature	°C	°F
Partial vapor pressure	mbar	psi
Wet bulb temperature	°C	°F
Absolute humidity	g/m <sup>3</sup>	gr/ft <sup>3</sup>
Mix ratio	g/kg	gr/lb
Specific enthalpy	kJ/kg	BTU/lb

	SI	US
Frost point temperature	°C	°F
Heat index	°C	°F

Table 10

- **Atmospheric pressure:** AirGate Air+ uses the atmospheric pressure value to calculate the psychrometric variable defined by the user. The standard value used by this device is 1013 mbar (14.7 psi). However, you can refine this information by entering the value read by another reference instrument.

Atmospheric pressure can vary depending on altitude or due to the conditions of the process itself.

	<b>To establish communication between the RHT Air+ and the AirGate Air+, the <u>Spreading Factor</u> and <u>Channel</u> parameters must be identical in both devices.</b>
---	---

- **Calculated channel:** Allows you to enable and define a channel to be calculated based on the temperature and humidity values. The calculated variable options available are:
  - Dry bulb temperature
  - Wet bulb temperature
  - Frost point temperature
  - Dew point temperature
  - Specific enthalpy
  - Partial vapor pressure
  - Mixture ratio
  - Absolute humidity
  - Heat index

For specific explanations of each variable, see [ATTACHMENT 1 – NOTIONS OF PSYCHROMETRICS](#).

## 11.3 USING NXPERIENCE TO CONFIGURE YOUR RHT AIR+

Below is a description of each of the possible configuration parameters, grouped by section.

### 11.3.1 GENERAL PARAMETERS

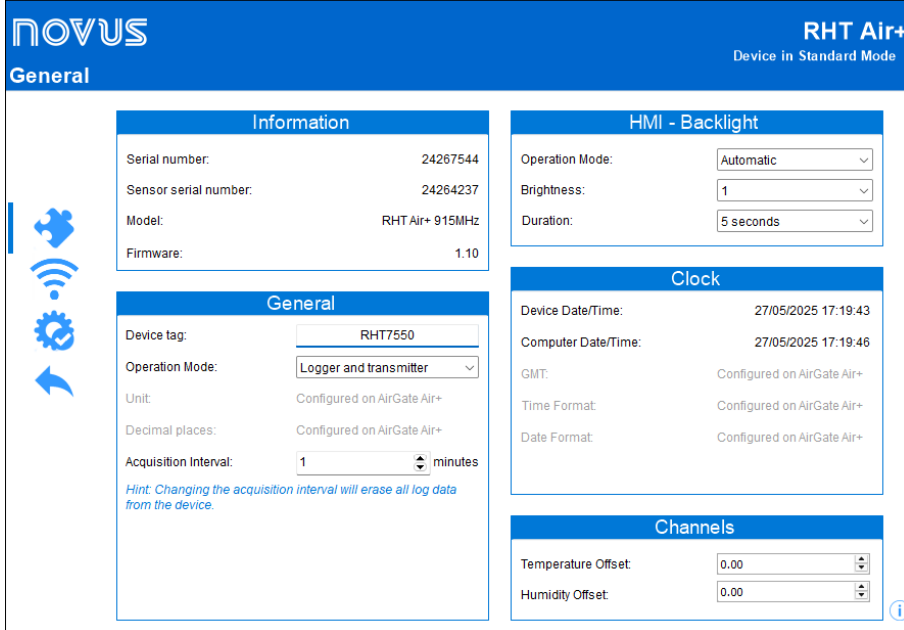

The screenshot shows the configuration interface for the NOVUS RHT Air+ device in Standard Mode. The 'General' section is active, displaying several configuration panels:

- Information:** Serial number: 24267544, Sensor serial number: 24264237, Model: RHT Air+ 915MHz, Firmware: 1.10.
- HMI - Backlight:** Operation Mode: Automatic, Brightness: 1, Duration: 5 seconds.
- General:** Device tag: RHT7550, Operation Mode: Logger and transmitter, Unit: Configured on AirGate Air+, Decimal places: Configured on AirGate Air+, Acquisition Interval: 1 minutes. A hint states: "Hint: Changing the acquisition interval will erase all log data from the device."
- Clock:** Device Date/Time: 27/05/2025 17:19:43, Computer Date/Time: 27/05/2025 17:19:46, GMT: Configured on AirGate Air+, Time Format: Configured on AirGate Air+, Date Format: Configured on AirGate Air+.
- Channels:** Temperature Offset: 0.00, Humidity Offset: 0.00.

Figure 30

#### INFORMATION

- **Serial number:** Displays the unique identification number of the device. The serial number is also used to register the device in **NOVUS Cloud**.
- **Sensor serial number:** Displays the identification number of the sensor.
- **Model:** Displays the model of the device.
- **Firmware version:** Displays the firmware version saved on the device.

## GENERAL SETTINGS

- **Device name:** Allows you to assign an ID to the device. The field allows up to 20 alphanumeric characters.  
In **AirGate Air+**, this information will be indicated as Tag.
- **Operation mode:** Allows you to set the operating mode of the **RHT Air+**.  
When configuring **RHT Air+** as a **Logger and Transmitter**, the **RHT Air+** will connect to an **AirGate Air+** and publish the data collected at each configured acquisition interval. The data will be recorded locally and then transmitted to the **AirGate Air+**.  
When configuring **RHT Air+** as a **Logger**, the device can be used without connecting to an **AirGate Air+** and without being provisioned to a network. This saves battery power and does not require a Gateway. This configuration is suitable for situations requiring a few devices and manual data collection. The data will only be recorded locally. For more information, see [USING RHT AIR+ AS A DATA LOGGER](#).
- **Unit:** The unit will be displayed as configured on the **AirGate Air+**.
- **Decimal places:** The decimal places will be displayed as configured on the **AirGate Air+**.
- **Acquisition interval:** Allows you to set the desired periodicity of temperature and humidity logs. This interval also defines the interval for sending information to **AirGate Air+**, since the data will be published as soon as it is recorded in memory.

## HMI

- **Operation mode:** Allows you to set the operating mode of the display to save energy. It is possible to always keep the display active or activate it by pressing the multifunction key.
- **Brightness:** Allows you to set the brightness of the display. The higher the intensity, the greater the energy consumption.
- **Duration:** Allows you to enable the Backlight. If enabled, it allows you to define how long (in seconds) it will remain active after the multifunction key is pressed.



The duration of the Backlight and the intensity of the Backlight are parameters that have a direct impact on the life of the internal batteries.

## CLOCK

- **Device Date/Time:** Displays the date and time set in the memory of the device.
- **PC Date/Time:** Displays the date and time of the Windows system, which will be used by **NXperience** to set the device's clock at the time the configuration is sent.
- **GMT:** The GMT will be displayed as configured on the **AirGate Air+**.
- **Time format:** The time format will be displayed as configured on the **AirGate Air+**.
- **Date format:** The date format will be displayed as configured on the **AirGate Air+**.

## CHANNELS

- **Temperature Offset:** Allows you to adjust the temperature reading by adding a configurable fixed value ( $\pm 10$ ) to all measurements.
- **Humidity Offset:** Allows you to adjust the humidity reading by adding a configurable fixed value ( $\pm 10$ ) to all measurements.

### 11.3.2 CONNECTIONS

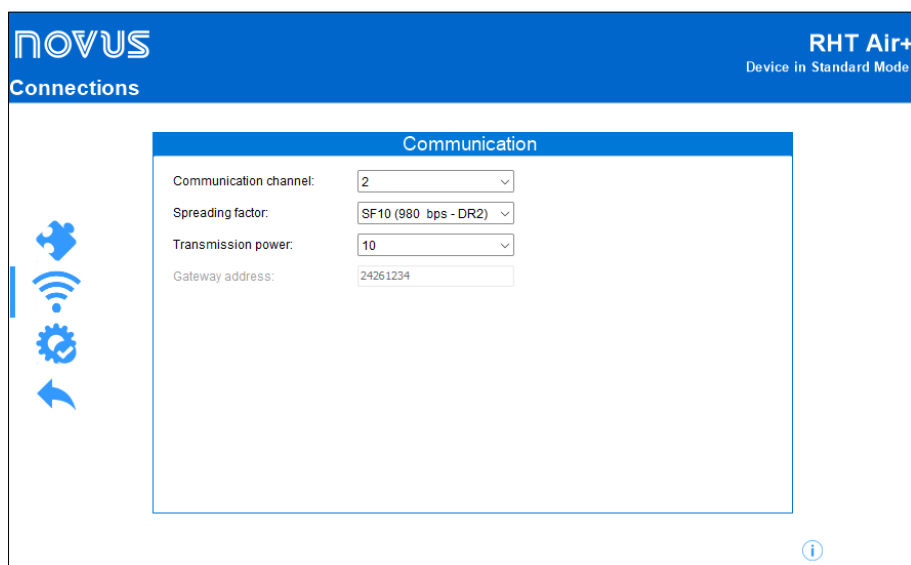

Figure 31

- **Communication channel:** Allows you to set a value for the communication channel. This parameter helps to resolve network conflicts.  
If there is another **AirGate Air+** in the coverage area, it is recommended that they operate on separate channels so that there are no communication failures between **AirGate Air+** and **RHT Air+**.

- **Spreading factor:** Characteristic parameter of LoRa communication, it defines the robustness of the **Air+** network communication. The side effect of this parameter is high energy consumption as the level of communication reliability increases.  
The propagation factors allowed are SF7 to SF11, the latter guaranteeing the best network robustness but with the highest energy consumption. In most cases, it is recommended to use SF10.
- **Transmission power:** By default and to save energy while maintaining communication with the **AirGate Air+**, **RHT Air+** automatically adjusts the transmission power. However, if there is no such link, **RHT Air+** will use the value set in this parameter as a basis for initiating communication with the **AirGate Air+**.

	<b>To establish communication between RHT Air+ and AirGate Air+, the <u>Spreading Factor</u> and <u>Channel</u> parameters must be identical in both devices.</b>
---	---

- **Gateway address:** Allows you to manually register the **AirGate Air+** to which the **RHT Air+** will request the link. By default, the **RHT Air+** scans the network for a connection to the **AirGate Air+**. If the link between the **AirGate Air+** and the **RHT Air+** is made, this register will be filled in automatically.

## 11.4 AIRGATE AIR+: DIAGNOSTIC

By clicking on the **Diagnostics** button on the **NXperience** home screen, you can view the diagnostics tab.

### 11.4.1 COMMUNICATION

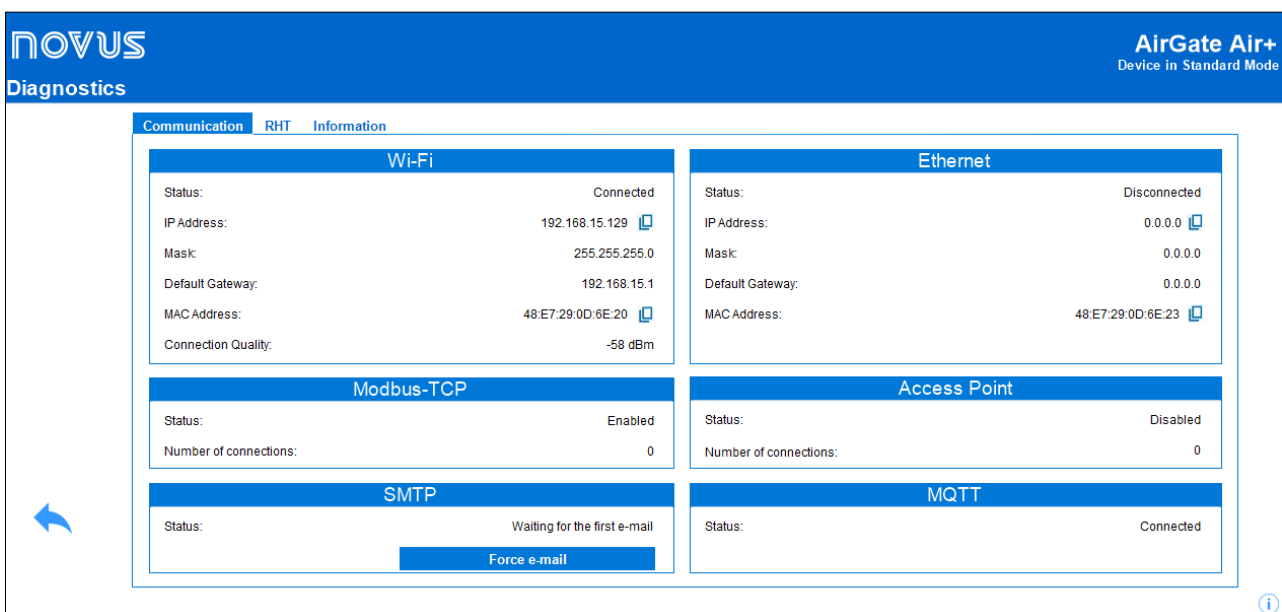

Figure 32

#### WI-FI

Displays information about the Wi-Fi connection of the device:

- **Status:** Displays information about the status of the Wi-Fi connection.
- **IP address:** Displays information about the IP address configured.
- **Mask:** Displays information about the mask configured.
- **Default gateway:** Displays information about the default Gateway configured.
- **MAC address:** Displays information about the MAC address of the device.
- **Connection Quality:** Displays information about the quality of the connection.

#### ETHERNET

Displays information about the Ethernet connection of the device:

- **Status:** Displays information about the status of the Ethernet connection.
- **IP address:** Displays information about the IP address configured.
- **Mask:** Displays information about the mask configured.
- **Default gateway:** Displays information about the default Gateway configured for the device.
- **MAC address:** Displays information about the MAC address of the device.

#### MODBUS-TCP

Informs whether the Modbus-TCP protocol is enabled. If enabled, it displays the number of currently active connections.

## ACCESS POINT

Informs whether the access point is being generated. If enabled, it displays the number of currently active connections.

## MQTT

Informs whether the MQTT protocol is enabled.

## SMTP

Informs whether the SMTP protocol is enabled. If enabled, it displays information about the last check performed and its status.

### 11.4.2 RHT

Slot	Tag	Humidity	Temperature	Dew Point	Latest publications			Via MQTT	Via SMTP	SN	FW
					Qty	First	Last				
1	RHT_CUR1	53.0 %	23.3°C	13.8°C	8952	24/01/2025 17:59:37	29/01/2025 13:51:18	29/01/2025 13:51:18	Disabled	24287549	1.01
2	RHT_LUK1	51.1 %	24.5°C	13.9°C	7152	24/01/2025 14:41:11	29/01/2025 13:52:07	29/01/2025 13:52:07	Disabled	24287559	1.02
3	RHT_ROD1	51.8 %	24.4°C	14.1°C	7205	24/01/2025 13:48:50	29/01/2025 13:51:22	29/01/2025 13:51:22	Disabled	24287554	1.02
4	RHT_SIL1	50.0 %	24.5°C	13.6°C	3596	24/01/2025 13:59:04	29/01/2025 13:51:11	29/01/2025 13:51:11	Disabled	24287582	1.02
5	RHT_SW1	51.2 %	24.8°C	13.9°C	3597	24/01/2025 13:59:37	29/01/2025 13:51:33	29/01/2025 13:51:33	Disabled	24287558	1.02
6	RHT_SAN1	58.8 %	23.5°C	14.8°C	3563	24/01/2025 15:07:48	29/01/2025 13:51:42	29/01/2025 13:51:42	Disabled	24287564	1.02
7	RHT_MIG1	64.6 %	23.0°C	15.9°C	3563	24/01/2025 15:07:35	29/01/2025 13:51:29	29/01/2025 13:51:29	Disabled	24287571	1.02
8	RHT_EuRo	51.1 %	24.3°C	13.7°C	7045	24/01/2025 16:27:48	29/01/2025 13:51:32	29/01/2025 13:51:32	Disabled	24287544	1.00
9	RHT_MAY1	46.6 %	23.4°C	11.2°C	288	28/01/2025 13:52:39	29/01/2025 13:47:37	29/01/2025 13:47:37	Disabled	24287586	1.02
10	RHT_MAY3	46.1 %	23.3°C	11.1°C	78	29/01/2025 07:27:01	29/01/2025 13:52:00	29/01/2025 13:52:00	Disabled	24287556	1.02
11	RHT_MAY4	58.7 %	21.9°C	13.8°C	1478	24/01/2025 10:42:57	29/01/2025 13:47:57	29/01/2025 13:47:57	Disabled	24287555	1.00
12	RHT_BAN1	51.8 %	25.4°C	14.8°C	7147	24/01/2025 14:46:15	29/01/2025 13:52:06	29/01/2025 13:52:06	Disabled	24287543	1.02
13	RHT_COZ1	49.0 %	25.4°C	14.0°C	7181	24/01/2025 14:12:03	29/01/2025 13:51:58	29/01/2025 13:51:58	Disabled	24287585	1.02
14	RHT_AUS1	51.1 %	23.0°C	12.9°C	7053	24/01/2025 16:19:19	29/01/2025 13:51:22	29/01/2025 13:51:22	Disabled	24287570	1.00
15	RHT_CAN1	69.1 %	23.7°C	18.3°C	7049	24/01/2025 16:23:14	29/01/2025 13:51:27	29/01/2025 13:51:27	Disabled	24287550	1.00
16	RHT_FOR1	64.8 %	23.8°C	17.4°C	3459	24/01/2025 18:34:53	29/01/2025 13:50:51	29/01/2025 13:50:51	Disabled	24149175	1.01

Figure 33

Displays information about all RHTs paired with AirGate Air+.

- **Slot:** Displays the position of the RHT Air+ in the internal table of the AirGate Air+. To access the logs of a specific RHT Air+ via Modbus-TCP, it will be necessary to link it to the slot.
- **Tag:** Displays the text identifier associated with the RHT Air+, information that can be defined by the user.
- **Humidity:** Displays the last humidity value received by RHT Air+.
- **Temperature:** Displays the last temperature value received by RHT Air+.
- **Internal channel:** Displays the value of the internal channel based on the latest humidity and temperature data received by RHT Air+.



The name of this parameter will change according to the variable selected in the **Calculated channel** parameter (see [AIR+ NETWORK](#) subsection of [USING NXPERIENCE TO CONFIGURE YOUR AIRGATE AIR+](#)).

- **Logs:** Displays the diagnosis of the memory area reserved for logs received by RHT Air+.
  - **Quantity:** Displays the number of logs stored in the memory of AirGate Air+.
  - **First:** Displays the time of the oldest log in the memory of AirGate Air+.
  - **Last:** Displays the time of the most recent log in the memory of AirGate Air+.
- **Via MQTT:** Displays the time of the last log published via MQTT.
- **Via SMTP:** Displays the time of the last alarm signaled via email.
- **SN:** Displays the serial number of RHT Air+.
- **FW:** Displays the firmware version of RHT Air+.



If the last temperature, humidity, and internal channel value is **-32000**, there is a problem with the temperature and humidity sensor tip on the RHT Air+.

If the disconnection alarm is enabled (see [ALARMS](#) section of [CONFIGURATION SOFTWARE](#)) and there is no data received from the RHT Air+ within the interval set for the alarm, the last humidity, temperature, and internal channel values will become invalid. This will return to **-22000**.

### 11.4.3 INFORMATION

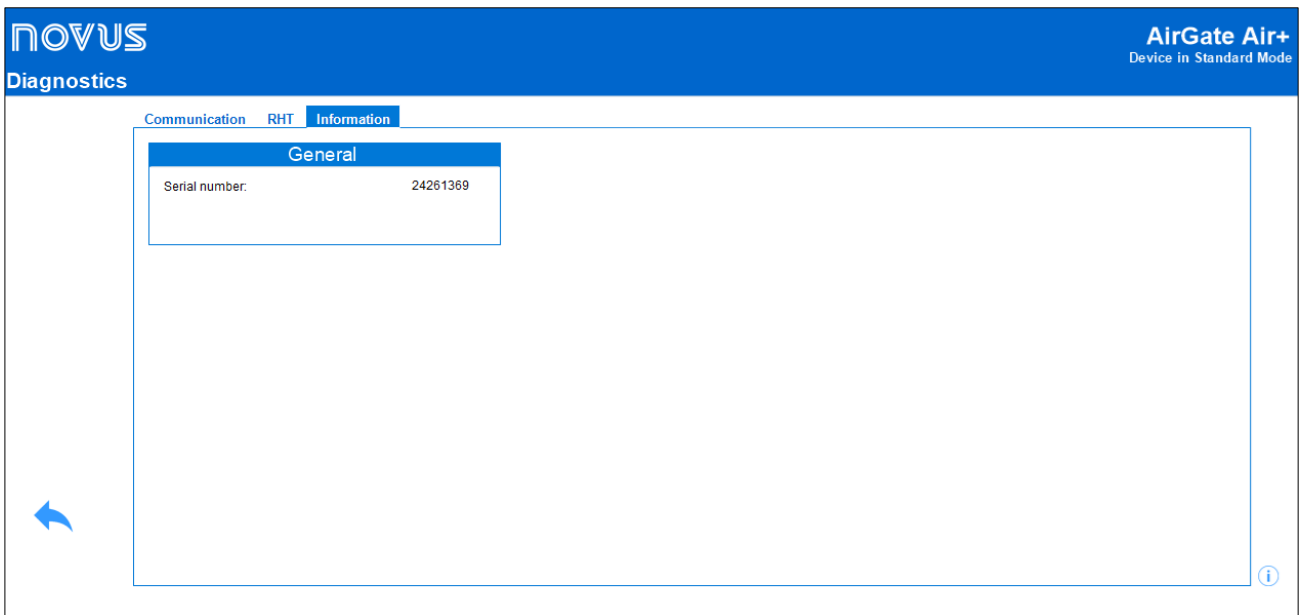

Figure 34

Displays the serial number of **AirGate Air+**.

### 11.5 RHT AIR+: DIAGNOSTIC

By clicking on the **Diagnostics** button on the **NXperience** home screen, you can view the diagnostics tab.

#### 11.5.1 LOGS

Displays information on the status of the logs, such as the number of recorded logs, the available memory, the date of the first and last log present in the memory of **RHT Air+**.

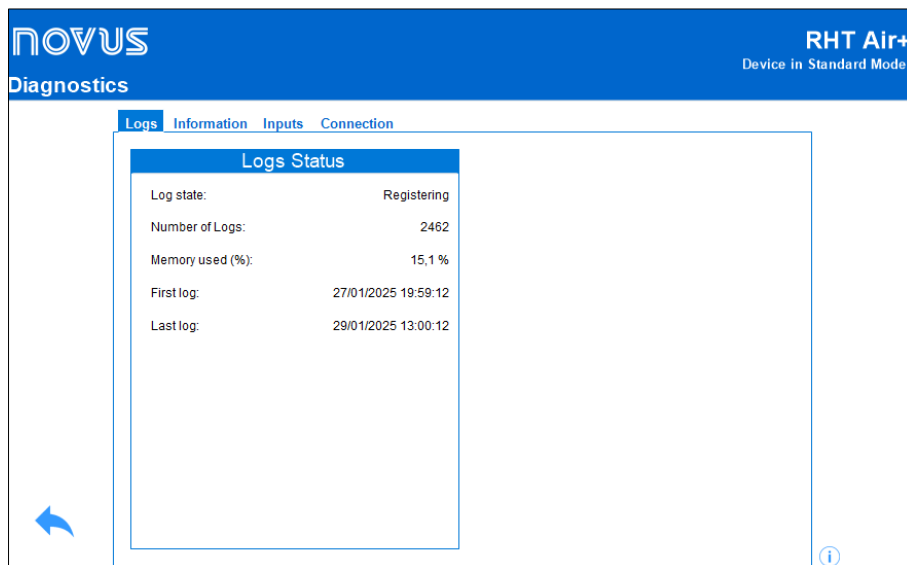

Figure 35

### 11.5.2 INFORMATION

Displays identification information about the device, such as tag and serial number, as well as firmware version and operating mode, among others. It also displays the battery voltage value and the available percentage level.

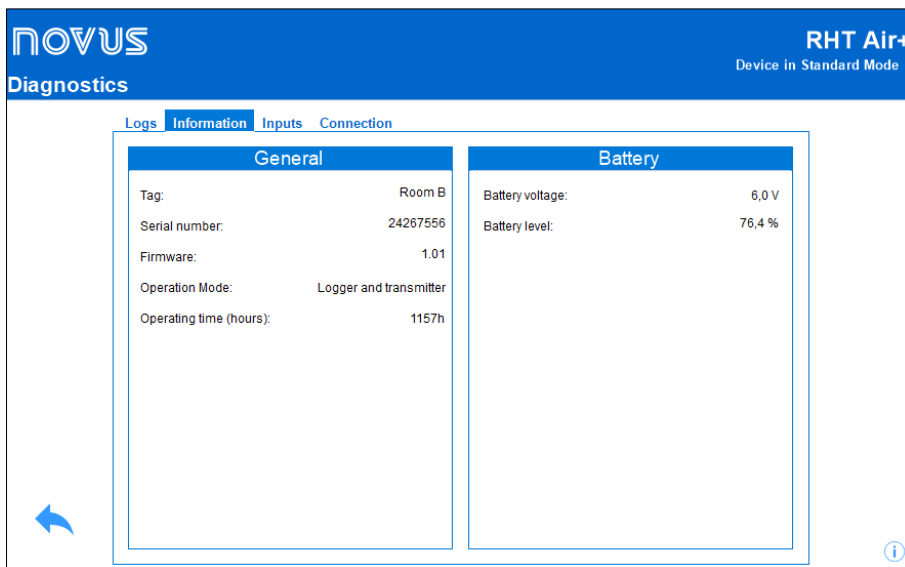

Figure 36

### 11.5.3 INPUTS

Displays information about the sensor and the temperature and humidity.

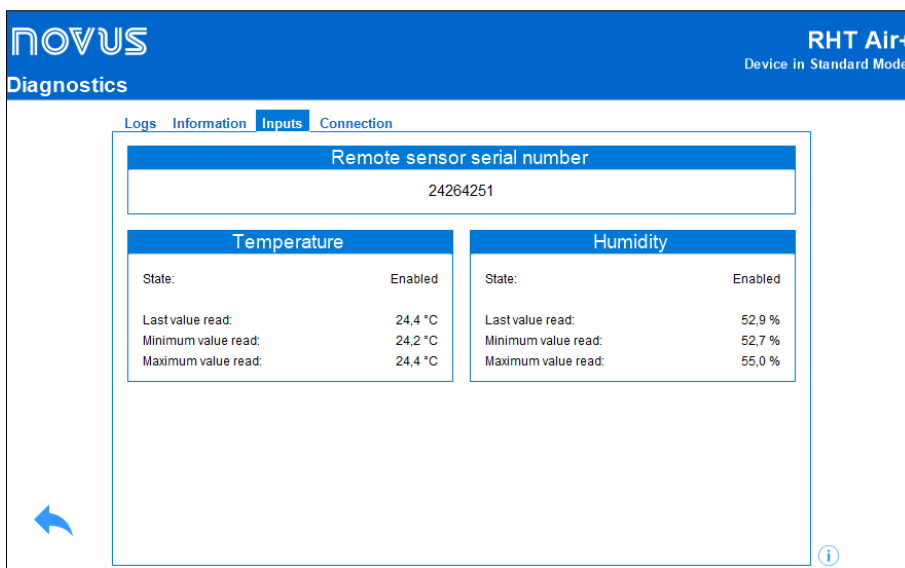

Figure 37

#### SENSOR PROBE SERIAL NUMBER

Displays the serial number of the sensor probe connected to the RHT Air+. If it is not present or in error, **NXperience** will display the value -1.

#### TEMPERATURE

Displays the minimum and maximum values recorded and the last temperature value.

#### HUMIDITY

Displays the minimum and maximum values recorded and the last humidity value.

## 11.5.4 CONNECTION

Displays information about the connection to the **AirGate Air+**, such as channel, propagation factor and serial number. Connection statistics are displayed by means of attempts and messages transmitted and received.

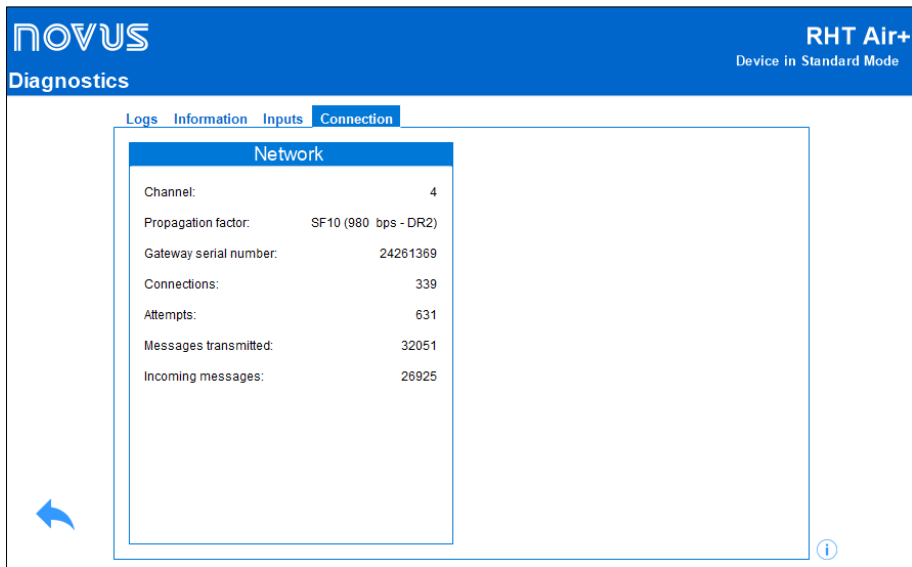

The screenshot shows the NOVUS RHT Air+ Diagnostics interface. The top bar is blue with the NOVUS logo on the left and 'RHT Air+ Device in Standard Mode' on the right. Below the bar, the 'Diagnostics' section is active, and the 'Connection' tab is selected. A 'Network' window is open, displaying the following statistics:

Network	
Channel:	4
Propagation factor:	SF10 (980 bps - DR2)
Gateway serial number:	24261369
Connections:	339
Attempts:	631
Messages transmitted:	32051
Incoming messages:	26925

There is a blue arrow icon in the bottom left corner of the main window and a help icon (i) in the bottom right corner.

Figure 38

## 12 USING RHT AIR+ AS A DATA LOGGER

### 12.1 DATA LOGGER MODE

This mode of operation is suitable for situations requiring only a few **RHT** devices and that can accommodate manual data collection. Logged data are stored locally in the device's internal memory, in a circular buffer. The frequency at which data must be collected (locally via USB using **NXperience** software) is directly related to the configured logging interval.

For example, if a 5-minute logging interval is set, **RHT Air+** will store approximately 16,000 logs, and those data should be downloaded within roughly 50 days to avoid log overlapping and consequent data loss.

When **RHT Air+** is configured as a data logger, the device can operate without connection to an **AirGate Air+** or being provisioned onto a network. This conserves battery life and does not require a Gateway.



1. In Data Logger mode, **RHT Air+** is **NOT** compatible with **NOVUS Air+** protocol.
2. If the device exceeds 16,000 logs, old data will be overwritten and lost. Make sure you perform the collection before then!

### 12.2 CONFIGURING NXPERIENCE

When configured via USB using the **NXperience** software, the **RHT Air+** can be set to logger-only mode. In this mode you can configure parameters such as temperature unit (°C or °F), number of decimal places, and acquisition interval (read-and-log interval). You can also adjust the device's internal clock.

While operating in logger-only mode, the date and time must be set from a computer. Simply choose **Synchronize with computer date and time** option in the **NXperience** software.

The screenshot shows the configuration interface for a NOVUS RHT Air+ device. The interface is titled "NOVUS RHT Air+ Device in Standard Mode" and "General". It is divided into several sections:

- Information:** Serial number: 24267544, Sensor serial number: 24264234, Model: RHT Air+ 915MHz, Firmware: 1.10.
- General:** Device tag: RHT7550, Operation Mode: Logger only, Unit: °C, Decimal places: 1, Acquisition Interval: 1 minutes. A hint states: "Hint: Changing the acquisition interval will erase all log data from the device."
- HMI - Backlight:** Operation Mode: Automatic, Brightness: 1, Duration: 5 seconds.
- Clock:** Device Date/Time: 02/06/2025 09:55:06, Computer Date/Time: 02/06/2025 09:55:15, GMT: -03:00, Time Format: 24h, Date Format: DD/MM/YYYY. A checkbox for "Synchronize with computer date and time" is checked.
- Channels:** Temperature Offset: 0.00, Humidity Offset: 0.00.

Figure 39



In this mode, data must always be collected locally, via USB.

## 13 TECHNICAL SPECIFICATION

### 13.1 AIRGATE AIR+

FEATURES	AirGate Air+				
Memory	Type	Circular			
	Capacity	1,024,000 logs (2 quantities)			
Recording interval	2 to 720 minutes*				
Communication interfaces	USB	1 USB Type C. For configuration, download and diagnostics.			
	LoRa	Models			
			915 MHz	868 MHz	865 MHz
		Frequency [MHz]	915.4~927.4	865.15~869.85	865.15~866.86
		Bandwidth [kHz]	500	250	250
		Spreading factor	7~11	7~12	7~12
		Transmission power [dBm]	20	14	20
	Reception sensitivity	-136 dBm			
Ethernet	10/100 Mb/s, IEEE standard 802.3u.				
Wi-Fi	IEEE standard 802.11 b/g/n 2.4G GHz. Support for WPA-Personal (PSK) WPA/WPA2 TKIP/AES/TKIP and AES encryption.				
Protocols	IP	SMTP, NTP, MQTT, and Modbus-TCP.			
Power supply	External power supply	8~30 Vdc			
Protection index	IP20				
Environment	<ul style="list-style-type: none"> <li>Operating temperature: -10 to 60 °C (14 to 140 °F)</li> <li>Storage temperature: -20 to 70 °C (-4 to 158 °F)</li> <li>Humidity: 5 to 95 % RH (Non-condensed)</li> </ul>				
Dimensions	220 mm x 180 mm x 38 mm				
Housing	ABS + PC				
Software	<b>NXperience</b> (via USB) <b>NXperience Trust</b> (FDA 21 CFR part 11)				
Certifications	Anatel	07859-24-07089			
	FCC	Contains Wi-Fi module, FCC ID: 2AC7Z-ESPWROOM32D Contains LoRA module, FCC ID: 2ADHKR34M			
	ISED	Contains Wi-Fi module, IC: 21098- ESPWROOM32D <sup>1</sup> Contains LoRA module, IC: 20266-R34M			
	CE				

Table 11

\* The 915 MHz model can be configured with a log interval of 1 to 720 minutes, but it is recommended to use a log interval of 5 minutes or more. To increase performance, consider the maximum number of devices on the network in the ratio of 6 devices for each minute of logging interval.

\*\* The communication distance is reduced as the number of obstacles between the Gateway and the sensor increases.

<sup>1</sup> <https://ised-isde.canada.ca/site/spectrum-management-telecommunications/en/devices-and-equipment/radio-equipment-standards/radio-standards-specifications-rss/rss-gen-general-requirements-compliance-radio-apparatus#s4.3> (itens 4.3, 8.4)

13.2 RHT AIR+

FEATURES	RHT AIR+				
Temperature measurement	<ul style="list-style-type: none"> <li>• Range: -10 to 70 °C (14 to 158 °F)</li> <li>• Resolution: 0.1 °C</li> <li>• Accuracy: Typical: ± 0.2 °C   Maximum: ± 0.3 °C</li> </ul>				
Other sources of error:					
<b>Reproducibility</b>		<b>0.04 %</b>			
<p><b>Note:</b> When calibrating the transmitter through a Metrology Laboratory, it is necessary to consider that the calibration uncertainty must be added to the accuracy of the device.</p>					
Relative humidity measurement	<ul style="list-style-type: none"> <li>• Range: 0 to 100 % RH</li> <li>• Resolution: 0.1 C</li> <li>• Accuracy:</li> </ul>				
Other sources of error:					
<b>Hysteresis @ 25°C</b>		0.8 %RH			
<b>Reproducibility</b>		0.08 %RH			
<p><b>Note:</b> When calibrating the transmitter through a Metrology Laboratory, it is necessary to consider that the calibration uncertainty must be added to the accuracy of the device.</p>					
Memory	<b>Type</b>	Circular			
	<b>Capacity</b>	16,000 logs (2 quantities) 50 days with a 5-minute recording interval			
<b>Recording interval</b>	2 to 720 minutes**				
<b>Battery life</b>	Up to 2 years with 10-minute publishing interval, S10 and 14 db power.				
Communication interfaces	<b>USB</b>	1 USB Type C. For configuration, download and diagnostics.			
	<b>LoRa</b>	<b>Models</b>			
			<b>915 MHz</b>	<b>868 MHz</b>	<b>865 MHz</b>
		<b>Frequency [MHz]</b>	915.4~927.4	865.15~869.85	865.15~866.86
		<b>Bandwidth [kHz]</b>	500	250	250
<b>Spreading factor</b>	7~11	7~12	7~12		

FEATURES	RHT AIR+				
		<b>Transmission power [dBm]</b>	20	14	20
		<b>Radio coverage</b>	Up to 3 km with clear line of sight**, SF11, 20 dBm	Up to 2 km with clear line of sight**, SF12, 14 dBm	Up to 3 km with clear line of sight**, SF11, 20 dBm
		<b>Reception sensitivity</b>	-136 dBm		
<b>Power supply</b>	<b>Non-rechargeable batteries</b>	2 x 3.6 V 2500 mAh Lithium AA			
	<b>USB</b>	5 V ~ 1 A***			
<b>Display</b>	2 lines, 4 digits				
<b>Protection index</b>	<ul style="list-style-type: none"> <li>Housing: IP65</li> <li>Sensor: IP40</li> </ul>				
<b>Environment</b>	<ul style="list-style-type: none"> <li>Operating temperature: -10 to 70 °C (14 to 158 °F)</li> <li>Storage temperature: -20 to 70 °C (-4 to 158 °F)</li> <li>Humidity: 5 to 95 % RH (Non-condensed)</li> </ul>				
<b>Dimensions</b>	70 mm x 175 mm x 45 mm				
<b>Housing</b>	Polycarbonate (V2 flame retardant)				
<b>Software</b>	<b>NXperience</b> (via USB) <b>NXperience Trust</b> (FDA 21 CFR part 11)				
<b>Certifications</b>	<b>Anatel</b>	07860-24-07089			
	<b>FCC</b>	Contains LoRA module, FCC ID: 2ADHKR34M			
	<b>ISED</b>	Contains LoRA module, IC: 20266-R34M <sup>2</sup>			
	CE				

**Table 12**

\* The 915 MHz model can be configured with a log interval of 1 to 720 minutes, but it is recommended to use a log interval of 5 minutes or more. To increase performance, consider the maximum number of devices on the network in the ratio of 6 devices for each minute of logging interval.

\*\* Do not use cables longer than 1.5 m.

\*\*\* The communication distance is reduced as the number of obstacles between the Gateway and the sensor increases.

### 13.3 CERTIFICATIONS

#### FCC

This equipment has been tested and found to comply with the limits for a Class A digital device, pursuant to Part 15 of the FCC Rules. These limits are designed to provide reasonable protection against harmful interference when the device is used in a commercial environment. This device generates, uses and can radiate radio frequency energy and, if not installed and used in accordance with the instructions in this manual, may cause interference to radio communications.

Any changes or modifications not expressly approved by the party responsible for compliance could void the user's authority to operate this equipment.

**RF Exposure:** A distance of 20 cm shall be maintained between the antenna and users, and the transmitter module may not be co-located with any other transmitter or antenna.

*This device complies with part 15 of the FCC Rules. Operation is subject to the following two conditions: (1) This device may not cause harmful interference, and (2) this device must accept any interference received, including interference that may cause undesired operation.*

#### ANATEL

This device is homologated by ANATEL, according to the regulated procedures for conformity assessment of telecommunications products, and meets the technical requirements applied.

This equipment is not subject to protection from harmful interference and may not cause interference with duly authorized systems.

For more information, see the ANATEL website: [www.gov.br/anatel](http://www.gov.br/anatel).

#### CE Mark

This is a Class A product. In a domestic environment, this product may cause radio interference in which case the user may be required to take adequate measures.

<sup>2</sup> <https://ised-isde.canada.ca/site/spectrum-management-telecommunications/en/devices-and-equipment/radio-equipment-standards/radio-standards-specifications-rss/rss-gen-general-requirements-compliance-radio-apparatus#s4.3> (itens 4.3, 8.4)

## **ISED**

This device contains licence-exempt transmitter(s)/receiver(s) that comply with Innovation, Science and Economic Development Canada's licence-exempt RSS(s). Operation is subject to the following two conditions:

1. This device may not cause interference.
2. This device must accept any interference, including interference that may cause undesired operation of the device.

## 14 WARRANTY

Warranty conditions are available on our website [www.novusautomation.com/warranty](http://www.novusautomation.com/warranty).

## 15 ATTACHMENT I – NOTIONS OF PSYCHROMETRICS

Psychrometry is the study of the thermodynamic properties of dry air and water vapor mixtures. Obtaining psychrometric properties is of fundamental importance in the psychrometric processes of air conditioning, refrigeration, cooling and freezing, humidification and dehumidification of air, drying and dehydration of humid devices, as well as in environmental control and meteorology.

The psychrometric properties provided by RHT Air+ are:

- Dry Bulb Temperature
- Wet Bulb Temperature
- Frost Point Temperature
- Dew Point Temperature
- Specific Enthalpy
- Partial Vapor Pressure
- Mixture Ratio
- Relative Humidity
- Absolute Humidity
- Heat Index

### 15.1 DRY BULB TEMPERATURE | [°C] OR [°F]

It is simply the temperature of the air and water vapor mixture surrounding the thermometer.

### 15.2 WET BULB TEMPERATURE | [°C] OR [°F]

The wet bulb temperature is measured by a thermometer with bulb covered by a mesh (usually cotton) that is submerged in a recipient containing distilled water. Water evaporation draws out heat from the bulb, making the wet bulb thermometer indicate a temperature lower than the ambient air. Evaporation consumes heat, causing cooling. This evaporation, and consequently the wet bulb temperature, is greater when the atmospheric air is drier, and is null when the atmosphere is saturated with water vapor (relative air humidity equal to 100%).

### 15.3 FROST POINT TEMPERATURE | [°C] OR [°F]

The frost point temperature is the temperature to which air must be cooled, with constant pressure, to reach saturation (in relation to liquid water) and to settle in the form of frost on a surface.

### 15.4 DEW POINT TEMPERATURE | [°C] OR [°F]

The dew point is defined as the temperature to which the air must be cooled for water condensation to begin, meaning for the air to be saturated with water vapor. At a dew point temperature, the amount of water vapor present in the air is maximum.

The capacity to retain water by air is heavily dependent on temperature: warm air can retain more water. The dew point is typically used to represent the amount of water vapor in dry air or gas. At low humidity, changes in dew point temperature are greater than changes in relative humidity, allowing for greater measurement precision and control.

### 15.5 SPECIFIC ENTHALPY | [KJ/KG] OR [BTU/LB]

It is the energy contained in moist air by the amount of dry air. For a given mass of air to occupy a given volume at a given pressure, this occurs at the expense of energy. The higher the relative air humidity, the higher its specific enthalpy will be.

### 15.6 PARTIAL VAPOR PRESSURE [MBAR] OR [PSI]

The partial pressure of a gas in a gaseous mixture of ideal gases corresponds to the pressure that it would exert if it were occupying the whole container alone, at the same temperature as the ideal mixture. As such, the total pressure is calculated via the sum of partial pressures of the gases that make up the mixture.

### 15.7 MIXTURE RATIO | [G/KG] OR [GR/LB]

The mixture ratio is expressed as the ratio of the mass of water vapor per kilogram of dry air into any portion of the atmosphere separated for study. The mixture ratio varies with temperature, except if the temperature is lower than the dew point, or when the air is completely saturated with water vapor. In these conditions, the drop in temperature will cause forced water condensation.

### 15.8 RELATIVE HUMIDITY | [%RH]

Relative humidity expresses the percentage of water vapor contained in a certain amount of air. When the air reaches 100% relative humidity, it will have reached its maximum water absorption capacity. In this condition, the air is said to be saturated and water vapor condensation starts to be evident on the surfaces surrounded by this mixture.

### 15.9 ABSOLUTE HUMIDITY | [G/M<sup>3</sup>] OR [GR/FT<sup>3</sup>]

Absolute humidity expresses the mass of water vapor contained in each volume. If all the water of one cubic meter of air is condensed in a vessel, this vessel will contain all the absolute humidity of that portion of air and the amount of condensed water can be weighed to quantify the absolute humidity.

## 15.10 HEAT INDEX | [°C] OR [°F]

The heat index is a measure that combines air temperature with relative humidity to estimate the thermal sensation in hot conditions. It reflects how the human body perceives heat, considering the ability of sweat to evaporate and cool the body. When humidity is high, sweat evaporates more slowly, making the body feel hotter than the actual air temperature. Thus, the heat index is usually higher than the measured temperature, indicating a greater risk of discomfort and even conditions such as exhaustion or heatstroke.