



# NP785 Ultra Low Differential Pressure Transmitter



USER GUIDE V 2.0x C



	Recommended for devices with firmware version V 2.0x and higher.
--	------------------------------------------------------------------



1	SAFETY ALERTS.....	3
2	PRESENTATION.....	4
3	IDENTIFICATION.....	5
3.1	DEVICE IDENTIFICATION.....	5
3.2	DEVICE MODEL.....	5
4	INSTALLATION.....	7
4.1	MECHANICAL INSTALLATION.....	7
4.1.1	INSTALLATION RECOMMENDATIONS.....	7
4.1.2	DIMENSION.....	8
4.2	ELECTRICAL INSTALLATION.....	8
4.2.1	INSTALLATION RECOMMENDATIONS.....	8
4.2.2	SPECIAL PRECAUTION.....	8
4.2.3	ELECTRICAL CONNECTIONS.....	8
4.2.4	USB CONNECTION.....	9
4.2.5	AUTO-ZERO KEY.....	9
4.2.6	DIAGNOSTIC LED.....	9
5	SETTINGS.....	10
5.1	GENERAL SETTINGS.....	10
5.2	ALARM SETTINGS.....	10
5.3	ANALOG OUTPUT CONFIGURATION.....	11
6	USB INTERFACE.....	12
9.1	CONNECTING TO A COMPUTER.....	12
9.2	CONNECTING TO A SMARTPHONE.....	12
7	SERIAL COMMUNICATION.....	13
7.1	REGISTERS TABLE.....	13
8	SIGNOW SOFTWARE AND APP.....	17
8.1	SIGNOW SOFTWARE.....	17
8.2	SIGNOW APP.....	17
8.3	STARTING SIGNOW.....	17
8.4	CONNECTING TO SIGNOW SOFTWARE.....	18
8.5	CONNECTING TO SIGNOW APP.....	19
8.6	CONFIGURING THE DEVICE.....	20
8.6.1	GENERAL / BASIC.....	20
8.6.2	COMMUNICATION.....	20
8.6.3	INPUT.....	21
8.6.4	OUTPUT.....	21
8.6.5	ALARM.....	22
8.6.6	DIAGRAM.....	22
8.6.7	SECURITY.....	23
8.6.8	FIRMWARE UPDATE.....	23
8.7	PERFORMING DIAGNOSTICS.....	24
9	TECHNICAL SPECIFICATION.....	26
10	WARRANTY.....	28

## 1 SAFETY ALERTS

The symbols below are used in the device and throughout this manual to draw the user's attention to important information related to device safety and use.

		
<b>CAUTION</b> Read the manual fully before installing and operating the device.	<b>CAUTION OR HAZARD</b> Risk of electric shock.	<b>ATTENTION</b> Material sensitive to static charge. Check precautions before handling.

All safety recommendations appearing in this manual must be followed to ensure personal safety and prevent damage to the instrument or system. If the instrument is used in a manner other than that specified in this manual, the device's safety protections may not be effective.

## 2 PRESENTATION

**NP785 Ultra Low Differential Pressure Transmitter** uses a high precision differential pressure sensor and has the stability required to perform measurements in applications that require high sensitivity. It is a micro processed device with two communication interfaces: USB and RS485 via Modbus RTU protocol. The magnitude read by the sensor is provided through any of its interfaces, converted to a selected pressure unit from a set of options.

This device has a digital alarm output, which supports the configuration of the alarm condition, adjustable Setpoints and custom timing, among other functions. Its transmission output can be configured to operate in the 0-10 V and 4-20 mA standards, with adjustable range within the sensor limits, and has adjustable behavior options in case of sensor error.

The **SigNow** software and app are the key tools for configuring, downloading, and analyzing **NP785** data. They allow you to explore all features of the device.

**NP785 Ultra Low Differential Pressure Transmitter** is suitable for use in HVAC applications such as environmental monitoring or climate control or environmental monitoring of industrial processes where high accuracy is required at low pressure ranges.

### 3 IDENTIFICATION

#### 3.1 DEVICE IDENTIFICATION

The identification of the device model is described on its side label, together with information regarding its electrical connections and its serial number. **Figure 1** shows the information available in the device housing:

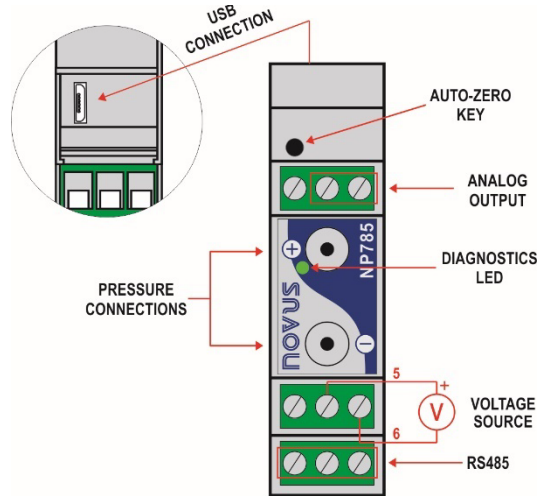

Figure 1 – NP785

#### 3.2 DEVICE MODEL

The NP785 Ultra Low Differential Pressure Transmitter line is available in 7 models:

- NP785-50 of  $\pm 50$  Pa
- NP785-100 of  $\pm 100$  Pa
- NP785-05 of  $\pm 5$  mbar
- NP785-20 of  $\pm 20$  mbar
- NP785-68 of  $\pm 68$  mbar
- NP785-400 of  $\pm 400$  mbar
- NP785-1000 of  $\pm 1000$  mbar

Model	Minimum Pressure Extended Range [-3.13%]	Minimum Pressure Extended Range [-1,25%]	Minimum Pressure	Maximum Pressure	Maximum Pressure Extended Range [103.13%]	Unity	Standard Configuration
50 Pa	-0.531	-0.513	-0.500	0.500	0.531	mbar	
	-7.97	-7.69	-7.50	7.50	7.97	mpsi	
	-0.213	-0.205	-0.200	0.200	0.213	inH2O	
	-5.42	-5.23	-5.10	5.10	5.42	mmH2O	
	-53.1	-51.3	-50.0	50.0	53.1	Pa	✘
100 Pa	-1.063	-1.025	-1.000	1.000	1.063	mbar	
	-15.94	-15.38	-15.0	15.00	15.94	mpsi	
	-0.425	-0.410	-0.400	0.400	0.425	inH2O	
	-10.84	-10.46	-10.20	10.20	10.84	mmH2O	
	-106.3	-102.5	-100.0	100.0	106.3	Pa	✘
5 mbar	-5.313	-5.125	-5	5	5.313	mbar	✘
	-77.06	-74.33	-72.52	72.52	77.06	mpsi	
	-2.133	-2.057	-2.007	2.007	2.133	inH2O	
	-54.17	-52.25	-50.98	50.98	54.17	mmH2O	
	-531.3	-512.5	-500	500	531.3	Pa	
20 mbar	-21.252	-20.500	-20	20	21.252	mbar	✘
	-308.24	-297.33	-290.08	290.08	308.24	mpsi	

Model	Minimum Pressure Extended Range [-3.13%]	Minimum Pressure Extended Range [-1,25%]	Minimum Pressure	Maximum Pressure	Maximum Pressure Extended Range [103.13%]	Unity	Standard Configuration
	-8.532	-8.230	-8.029	8.029	8.532	inH2O	
	-216.71	-209.04	-203.94	203.94	216.71	mmH2O	
	-2125.2	-2050.0	-2000	2000	2125.2	Pa	
68 mbar	-72.257	-69.700	-68	68	72.257	mbar	<b>x</b>
	-1062.60	-1025.00	-1000	1000	1062.60	mpsi	
	-29.753	-28.700	-28	28	29.753	inH2O	
	-743.82	-717.50	-700	700	743.82	mmH2O	
	-7438.2	-7175.0	-7000	7000	7438.2	Pa	
400 mbar	-425.040	-410.000	-400	400	425.040	mbar	<b>x</b>
	-6163.08	-5945.00	-5800	5800	6163.08	mpsi	
	-170.016	-164.000	-160	160	170.016	inH2O	
	-4250.40	-4100.00	-4000	4000	4250.40	mmH2O	
	-42504.0	-41000.0	-40000	40000	42504.0	Pa	
1000 mbar	-1062.600	-1025.000	-1000	1000	1062.600	mbar	<b>x</b>
	-15939.00	-15375.00	-15000	15000	15939.00	mpsi	
	-425.040	-410.000	-400	400	425.040	inH2O	
	-11157.30	-10762.50	-10500	10500	11157.30	mmH2O	
	-109872.8	-105985.0	-103400	103400	109872.8	Pa	

Table 1 – Measuring ranges

## 4 INSTALLATION

### 4.1 MECHANICAL INSTALLATION

NP785 Ultra Low Differential Pressure Transmitter is designed to be fixed on 35 mm DIN rail, as shown in Figure 2. The 35 mm DIN rail installation must be carried out after the device has been configured.

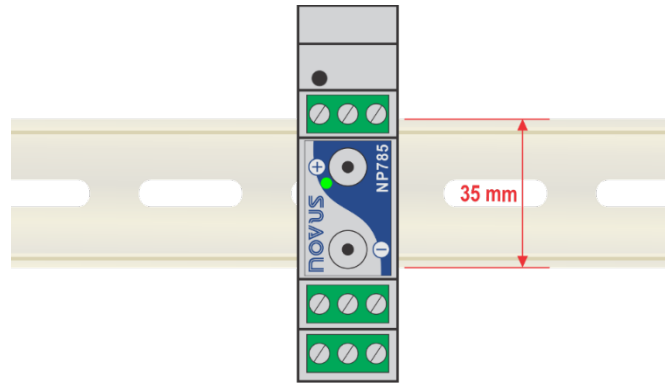

Figure 2 – Mechanical installation

#### 4.1.1 INSTALLATION RECOMMENDATIONS

- The pneumatic hoses must be installed after the device has been fitted to the 35 mm DIN rail.
- To avoid problems with condensation, the device must be installed above the point to be measured.
- The extension of the hoses does not affect the device accuracy. Very long hoses, however, can result in measurement delays.
- Hoses should not be bent, and sharp curves should not be taken. Such actions may result in airflow interruption and possible sensor reading blockage.

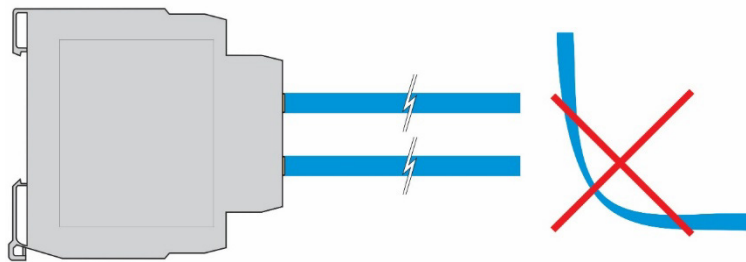

Figure 3 – Hose handling



The hose does not come with the device.

**Overpressure:** Excessive pressure, which exceeds the NP785 Ultra Low Differential Pressure Transmitter capacity, can cause irreversible mechanical and electrical damage to the device. To avoid damaging the operator or the device installer, follow the installation instructions and use the appropriate protection and device.

## 4.1.2 DIMENSION

Figure 4 shows the device dimensions:

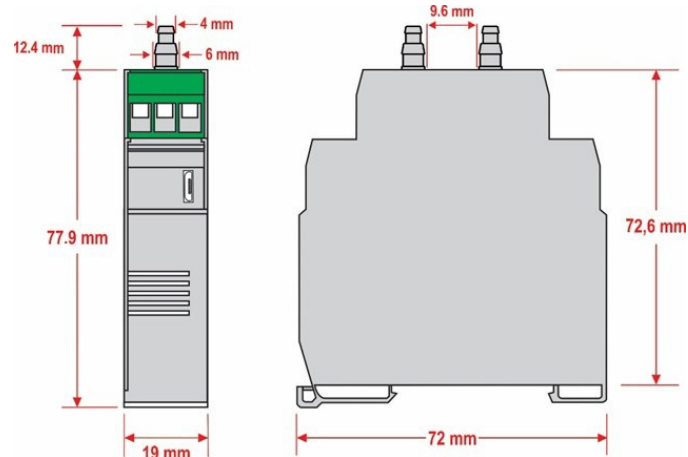

Figure 4 – Dimensions

## 4.2 ELECTRICAL INSTALLATION

### 4.2.1 INSTALLATION RECOMMENDATIONS

- Signal conductors should run through the plant separately from the power supply and output conductors. If possible, in grounded conduits.
- The power supply for electronic instruments must come from an appropriate grid for instruments.
- RC FILTERS (noise suppressor) are recommended in contactor coils, solenoids, etc.
- In control applications, it is essential to consider what could happen when some part of the system fails. The device's internal devices do not ensure total protection.
- Grounding helps limit the effects of noise due to electromagnetic interference (EMI). Run the grounding connection by using the grounding bolt and the grounding plane before turning on the device.

### 4.2.2 SPECIAL PRECAUTION

Because it is an electronic module, the device needs some care when handling:

- Due to the risk of damage caused by static electricity and may occur if the electronic circuit is exposed, the device should not be opened.
- Pay close attention when connecting the wires.
- Remember to pass all wires through a cable clip before completing electrical connections.
- When closing the housing, the cover should be placed again properly, ensuring proper sealing for this device.



### 4.2.3 ELECTRICAL CONNECTIONS

Figure 5 shows the device electrical connections:

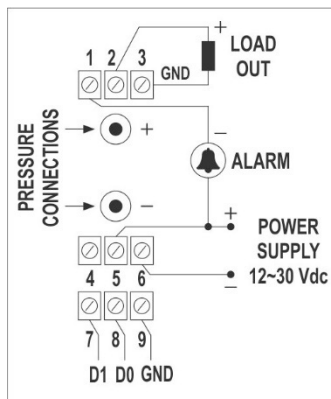

Figure 5 – Electrical connections

	Electrical Connection	Input
Output	1	ALARM
	2	OUT (Retransmission)
	3	GND
Power Supply	4	NC
	5	POWER
	6	GND
RS485	See table below.	

Table 2 – Electrical connections

The table below helps you connect the RS485 communication interface connectors:

D1	D	D+	B	Bi-directional data line.	Terminal 7
D0	$\bar{D}$	D-	A	Inverted bi-directional data line.	Terminal 8
C			Optional connection that improves communication performance.	Terminal 9	
GND					

Table 3 – RS485 connections

#### 4.2.4 USB CONNECTION

The USB connection is used exclusively for the device diagnosis and configuration. The USB interface is on the **NP785 Ultra Low Differential Pressure Transmitter** side.

It is recommended to configure the device before attached it to the DIN rail.

For more information, see [USB INTERFACE](#) chapter.

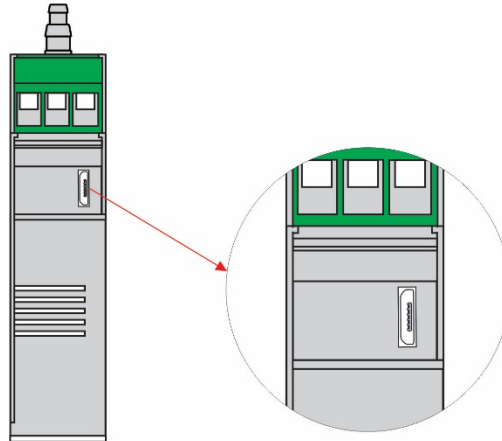

Figure 6 – USB Cable connection

#### 4.2.5 AUTO-ZERO KEY

You can use the Auto-Zero function to automatically reset the sensor by pressing the key located next to the USB interface for more than 2 seconds. If the pressure read from the sensor is within the allowable range (see **Table 10**), the sensor reading will be reset to zero.

You can also perform this function through the software (see [SIGNOW SOFTWARE AND APP](#) chapter). For more information about the Auto-Zero function, see [GENERAL SETTINGS](#) chapter.



**You can also define in the software whether the Auto-Zero function will reset the User Offset. By factory default the Auto-Zero function does not change previous Offset settings.**

#### 4.2.6 DIAGNOSTIC LED

This LED is used to perform a diagnosis during the operation of the device. When turning the device on, the LED will remain on for about 3 seconds and will flash in the following circumstances:

- LED on: The device is operating correctly, within the configured limits.
- LED flashing slowly: An alarm is triggered.
- LED flashing quickly: The measured pressure is outside the configured relay limits.
- One long flash: The Auto-Zero function has been performed successfully.
- Three short flashes: The Auto-Zero function was not performed.
- LED off: There was an error in the device.

**NP785 Ultra Low Differential Pressure Transmitter** is configurable by any of its interfaces. Due to the ease of use of the interface, it is recommended to configure via USB using the **SigNow** software or app, but the device can also be configured via Modbus RTU by writing directly in their configuration registers.

The description of the device registers, together with the configuration tables, can be found in the [SERIAL COMMUNICATION](#) chapter.

### 5.1 GENERAL SETTINGS

The differential pressure value is obtained by counting the digital analog converter of the device internal sensor. It is possible to select any of the following pressure units: mbar, mpsi, inH<sub>2</sub>O, mmH<sub>2</sub>O or Pa. Changing this setting reverts the transmission limits and alarm setpoints to the default values, which are the operation limits of the device.

The device also features **Auto-Zero** and **Offset** functions and an internal digital filter to process the measured signal.

You can use the **Auto-Zero** function to correct small differences in the sensor read value with no differential pressure applied, caused by mounting, device position or natural variations of the sensor over time. You can use the **Auto-Zero** function by pressing the **Auto-Zero** key for another 2 seconds or by using the **SigNow** software or app. If the pressure value read is within the allowable limits, the pressure reading will be reset to zero. You can also use the software to determine if the **Auto-Zero** function will reset the Offset value.

You can set an **Offset** value, which will be described in the selected pressure unit, to make small adjustments to the output value. The digital filter, in turn, allows you to set the 1st order filter time constant (in seconds). This helps to reduce the occurrence of noise effects and pressure peaks at the expense, however, of a faster response.

It is recommended to run the **Auto-Zero** function after changing the configuration of the device.

It is also possible to configure the parameters of Modbus RTU communication, such as Baud Rate, parity, and slave address of the device.

To differentiate between units of the same model, you can set an identifier on the device.

For test purposes, the device allows forcing the measurement of differential pressure, analog output, and alarm output. For each of these cases, you can configure a value to be forced and enable or disable forcing.

### 5.2 ALARM SETTINGS

**NP785 Ultra Low Differential Pressure Transmitter** has a digital alarm output. The digital output will be activated whenever an alarm situation is satisfied, except cases defined by some of its settings.

You can configure the alarm operation mode, high and low setpoints, hysteresis value, status transition timers, error condition and initial blocking.

Alarm configuration can be performed through the **SigNow** software or app (see [OUTPUT PARAMETER](#) section), allowing different operation modes:

- **Off:** No alarm situation is active.
- **Sensor Error:** While there is some error reading the sensor, the alarm output will remain on.
- **Below Lower Setpoint:** The alarm output will be activated when the current pressure is lower than the lower setpoint. To exit the alarm condition, the differential pressure must be greater than the lower setpoint plus the hysteresis value.
- **Above Higher Setpoint:** The alarm output will be activated when the differential pressure is higher than the upper setpoint. To exit the alarm condition, the differential pressure must be lower than the lower setpoint minus the hysteresis value.
- **Intra-range:** The alarm output will be activated when the differential pressure is higher than the lower set point and lower than the upper set point. To exit the alarm condition, the differential pressure must be greater than the upper setpoint plus the hysteresis value or lower than the lower setpoint minus the hysteresis value.
- **Extra-range:** The alarm output will be activated when the differential pressure is higher than the setpoint higher or lower than the lower setpoint. To exit the alarm condition, the differential pressure must be less than the upper setpoint minus the hysteresis value and higher than the lower setpoint plus the hysteresis value.

In addition to the alarm operation modes, other parameters, which do not apply to the Sensor Error mode, can be configured to refine the behavior of the alarm output:

- **Initial Blocking:** This parameter determines the use of the alarm output lock soon after the device is started. After initialization, a non-alarm condition is required for the alarm output to be enabled.
- **Error Condition:** The status of this parameter determines whether the alarm output will remain on or off in case of sensor failure.
- **Hysteresis:** This parameter stores the pressure value that, with the values of the set points, determines the limit value to leave the alarm situation. **Figure 7** shows the conditions for alarm activation and deactivation.

The alarm output can be timed by means of the **Time On** and **Time Off** parameters. For a given status transition to occur, the device must remain in the new status for a period equal to the one configured in the respective transition parameter. These values are initialized to 0 by default.

**Extra-range** mode is the default mode of alarm output. The default values of the setpoints, in turn, are the operating limits of the device. Any changes in the pressure unit configuration readjust the values of the set points to the operating limits.

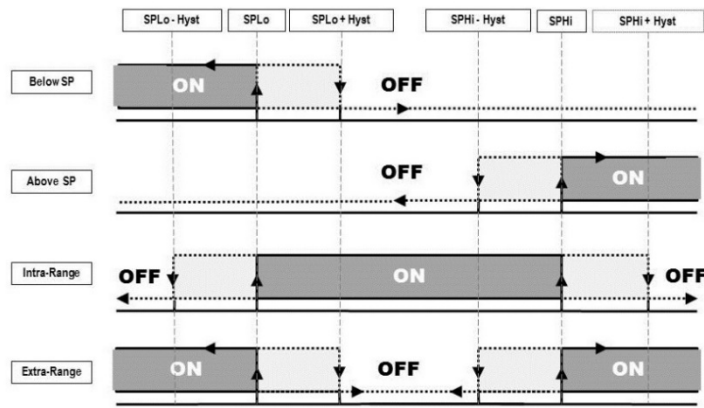

Figure 7 – Conditions of activation and deactivation of the different alarm modes

### 5.3 ANALOG OUTPUT CONFIGURATION

The device has a configurable analog output. You can configure it using the **SigNow** software or app (see [OUTPUT PARAMETERS](#) section), and you can define: the electrical pattern, the error mode, and the excursion range of the pressure to be transmitted.

The electrical pattern can be selected between 0-10 V and 4-20 mA modes, and the error mode determines the behavior of the analog output in case of sensor failure, as shown in table below:

Mode	ERROR MODE		
	Low	High	Low/High*
0 – 10 V	0 V	10 V	< Minimum Limit → 0 V
			Sensor error → 10 V
			> Maximum Limit → 10 V
4 – 20 mA	3.6 mA	21.0 mA	< Minimum Limit → 3.6 mA
			Sensor error → 21.0 mA
			> Maximum Limit → 21.0 mA

\* Available starting with firmware version 1.20.

Table 4 – Behavior of the analog output in case of sensor failure

The excursion of the electric signal respects the values set in the configuration of the lower and upper transmission limits, which allows customizing the differential pressure range. The factory setting also defines the upper and lower limits of the sensor as the maximum operating limits of each respective model.

The 4-20 mA output follows the NAMUR NE-43 recommendations:

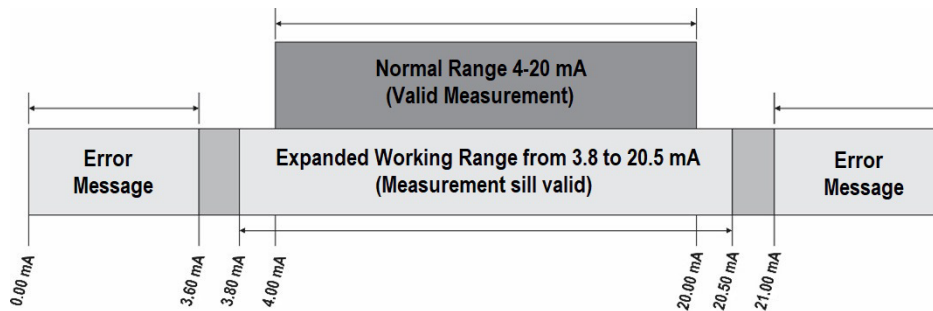

Figure 8 – 4-20 mA output

The device leaves the factory with the 4-20 mA electrical standard and with the pressure unit configured according to the selected model (see [Table 1](#)). Any changes in the pressure unit configuration readjust the values of the transmission limits to the device operating limits.

## 6 USB INTERFACE

### 9.1 CONNECTING TO A COMPUTER

The USB interface is used to CONFIGURE or MONITOR the device.

To CONFIGURE, you should use **SigNow** software or **SigNow** app, which offer features to create, view, save, and open configurations from the device or from files on your computer. The feature to save and open settings in files allows you to transfer settings between devices and create backups.

You can update the **NP785 Ultra Low Differential Pressure Transmitter** firmware (internal software) via the USB interface.

To MONITOR, you can use any supervisory (SCADA) or laboratory software that supports Modbus RTU communication over a serial communication port. When connected to the USB interface of a computer, **NP785 Ultra Low Differential Pressure Transmitter** will be recognized as a conventional serial port (COM x).

You should use **SigNow** software or consult the Device Manager in the Windows Control Panel to identify the COM port assigned to the device. To MONITOR, refer to the Modbus memory mapping in the device communication manual and the supervisory software documentation.

To use the USB communication, follow the steps below:

- Download **SigNow** software (see [SIGNOW SOFTWARE](#) section) from our website.
- Install the software on the computer to be used. The USB drivers required for the operation of the communication will be installed along with the software.
- Connect the USB cable between the device and the computer. The device does not need to be powered. The USB interface will provide enough power for communication operation (other device functions may not operate).
- Run the software, configure the communication, and start the device recognition.



The USB interface IS NOT ISOLATED from the relay outputs and alarm outputs. Its purpose is temporary use during CONFIGURATION and MONITORING periods. For the safety of people and devices, it should only be used when the device is fully disconnected from the external power input.



In any other situation it is possible to use the USB interface, but it requires careful consideration by the people performing the installation.

For MONITORING over long periods and with the inputs and outputs connected, it is recommended to use the RS485 interface, available or optional in most of our devices.

### 9.2 CONNECTING TO A SMARTPHONE

Smartphones with On the Go (OTG) technology can be directly connected to the device via the USB input. By connecting the OTG cable to the smartphone, you can recognize and configure your **NP785 Ultra Low Differential Pressure Transmitter** by running **SigNow** app.

To use the USB communication, follow the steps below:

- Download **SigNow** app from *Google Play Store* or *App Store*.
- Install the app on the smartphone to be used.
- Connect the USB cable between the device and the computer. The device does not need to be powered. The USB interface will provide enough power for communication operation (other device functions may not operate).
- Run the software, configure the communication, and start the device recognition.



If you position the cable end incorrectly, it is possible that the device will not be recognized by the application.

## 7 SERIAL COMMUNICATION

NP785 Ultra Low Differential Pressure Transmitter can be recognized on an RS485 network with Modbus RTU protocol as a slave device. All the configurable parameters of the device can be read and/or written via serial communication.

The device supports writing in Broadcast mode, using the slave address Modbus 0.

The available Modbus commands are as follows:

03 – Read Holding Register

05 – Write Single Coil

06 – Write Single Register

16 – Write Multiple Register

### 7.1 REGISTERS TABLE

OUTPUT REGISTERS						
Address	Register	Description	Type	Minimum	Maximum	Decimal
0	HR_PRESS	Differential pressure value	RO	Depends on model and unit of measure selected <sup>1</sup>		mbar: 3 decimal places mpsi: 2 decimal places inH2O: 3 decimal places mmH2O: 2 decimal places Pa: 1 decimal place
1	HR_PRESS_H					
2	HR_PRESS_MIN	Minimum differential pressure value	RO	Depends on model and unit of measure selected <sup>1</sup>		
3	HR_PRESS_MIN_H					
4	HR_PRESS_MAX	Maximum differential pressure value	RO	Depends on model and unit of measure selected <sup>1</sup>		
5	HR_PRESS_MAX_H					
6	HR_F_PRESS	Floating point differential pressure value <sup>2</sup>	RO	Depends on model and unit of measure selected <sup>1</sup>		Does not apply
7	HR_F_PRESS_H					
8	HR_F_PRESS_MIN	Minimum value of differential pressure in floating point <sup>2</sup>	RO	Depends on model and unit of measure selected <sup>1</sup>		
9	HR_F_PRESS_MIN_H					
10	HR_F_PRESS_MAX	Maximum value of differential pressure in floating point <sup>2</sup>	RO	Depends on model and unit of measure selected <sup>1</sup>		
11	HR_F_PRESS_MAX_H					

<sup>1</sup> Maximum and minimum values according to **Table 1**.

<sup>2</sup> The value of the registers should be interpreted as little-indian with byte inversion.

**Table 5 – Output registers**

ANALOG OUTPUT TRANSMISSION REGISTERS						
Address	Register	Description	Type	Minimum	Maximum	Standard
100	HR_SENSOR_TYPE	Sensor type	RO		0 → 5 mbar 1 → 20 mbar 3 → 68 mbar 4 → 400 mbar 5 → 1000 mbar 6 → 50 Pa 7 → 100 Pa	Depends on the model
101	HR_OUT1_TYPE	Retransmission output type	RW		0 → 4 a 20 mA 1 → 0 a 10 V	0
103	HR_OUT1_IN_HIGH_LIMIT	Upper limit of retransmission input	RW	Depends on model and unit of measure selected <sup>1</sup>		
104	HR_OUT1_IN_HIGH_LIMIT_H					
105	HR_OUT1_IN_LOW_LIMIT	Lower limit of retransmission input	RW	Depends on model and unit of measure selected <sup>1</sup>		
106	HR_OUT1_IN_LOW_LIMIT_H					
107	HR_OUT1_ERR	Error value	RW		0 → Low error 1 → High error 2 → Low/high error <sup>2</sup>	0
108	HR_OUT1_HIGH_LIMIT	Retransmission upper limit	RO	Depends on model and unit of measure selected <sup>1</sup>		
109	HR_OUT1_HIGH_LIMIT_H					
110	HR_OUT1_LOW_LIMIT	Retransmission lower limit	RO	Depends on model and unit of measure selected <sup>1</sup>		
111	HR_OUT1_LOW_LIMIT_H					

<sup>1</sup> Maximum and minimum values according to **Table 1**.

<sup>2</sup> Output behavior in case of error according to **Table 4**.

**Table 6 – Analog output transmission registers**

FILTER AND UNITY SYSTEM REGISTERS						
Address	Register	Description	Type	Minimum	Maximum	Standard
113	HR_PRESS_FLTR	Filter for differential pressure reading	RW	0	300	0
115	HR_UNIT_SYSTEM	Unit configuration	RW	0 → mbar 1 → mpsi 2 → inH2O 3 → mmH2O 4 → Pa		0

Table 7 – Filter and unity system registers

ALARM OUTPUT REGISTERS						
Address	Registers	Description	Type	Minimum	Maximum	Standard
178	HR_A1FU	Alarm type	RW	0 → Off 1 → Sensor error 2 → Below Setpoint 3 → Above Setpoint 4 → Inside range 5 → Out-of-range		0
179	HR_A1SPHI_IN	Alarm High setpoint for input	RW	Depends on model and unit of measure selected <sup>1</sup>		
180	HR_A1SPHI_IN_H					
181	HR_A1SPLO_IN	Alarm Low setpoint for input	RW	Depends on model and unit of measure selected <sup>1</sup>		
182	HR_A1SPLO_IN_H					
183	HR_A1BL	Alarm blocking	RW	0	1	0
184	HR_A1HY_IN	Alarm hysteresis input	RW	0	20 % of the maximum value <sup>1</sup>	0
185	HR_A1HY_IN_HI					
186	HR_A1HY	Alarm hysteresis	RO	0	20 % of the maximum value <sup>1</sup>	0
187	HR_A1HY_H					
188	HR_A1T1	Alarm ON time	RW	0	6500	0
189	HR_A1T2	Alarm OFF time	RW	0	6500	0
190	HR_A1IERR	Defines alarm status in case of sensor failure	RW	0	1	0
191	HR_A1SPHI	Alarm High Setpoint	RO	Depends on model and unit of measure selected <sup>1</sup>		
192	HR_A1SPHI_H					
193	HR_A1SPLO	Alarm Low Setpoint	RO	Depends on model and unit of measure selected <sup>1</sup>		
194	HR_A1SPLO_H					

<sup>1</sup> Maximum and minimum values according to Table 1.

Table 8 – Alarm output registers

MODBUS RS485 COMMUNICATION PORT CONFIGURATION REGISTERS						
Address	Register	Description	Type	Minimum	Maximum	Standard
137	HR_BAUD	Baud Rate	RW	0 → 1200 1 → 2400 2 → 4800 3 → 9600 4 → 19200 5 → 38400 6 → 57600 7 → 115200		4
138	HR_PRTY	Parity	RW	0 → No parity 1 → Odd parity 2 → Even parity		0
139	HR_ADDR	Slave Address	RW	1	247	1

Table 9 – Modbus RS485 communication port configuration registers

OFFSET REGISTERS						
Address	Registers	Description	Type	Minimum	Maximum	Standard
142	HR_F_OFFSET_IN	Input for differential pressure offset in floating point	RW	20 % of the minimum value <sup>1</sup>	+ 20 % of the maximum value <sup>1</sup>	0
143	HR_F_OFFSET_IN_HI					
144	HR_F_OFFSET	Differential pressure offset in floating point	RO	20 % of the minimum value <sup>1</sup>	+ 20 % of the maximum value <sup>1</sup>	0
145	HR_F_OFFSET_H					
147	HR_AZ_CLEAR_OFFSET	Sets the Auto-Zero action on Offset	RW	0	1	0
148	HR_FORCE_ZERO	Runs Auto-Zero function	RW	0	1	0
149	HR_PRESSURE_ZERO	Auto-Zero value	RO	-20 % of the minimum value <sup>1</sup>	+20 % of the maximum value <sup>1</sup>	Factory default
150	HR_PRESSURE_ZERO_H					

<sup>1</sup> Maximum and minimum values according to **Table 1**.

**Table 10 –** Offset registers

FORCE AND MINIMUM AND MAXIMUM REGISTERS						
Address	Register	Description	Type	Minimum	Maximum	Standard
152	HR_OUT1_FORCE_ENAB	Enables you to force the exit	RW	0	1	0
153	HR_OUT1_FORCE_VAL	Forced value for output	RW	0.00 V 3.60 mA	10.00 V 21.00 mA	0
154	HR_A1_FORCE_ENAB	Enables you to force the alarm	RW	0	1	0
155	HR_A1_STATE	Changes the alarm status	RW	0	1	0
156	HR_FORCE_IN_PRESS	Enables you to force the differential pressure	RW	0	1	0
157	HR_FORCE_PRESS	Input for the differential pressure value that was forced	RW	Depends on model and unit of measure selected <sup>1</sup>		
158	HR_FORCE_PRESS_HIGH					
159	HR_FORCE_PRESS	Differential pressure value that was forced	RO	Depends on model and unit of measure selected <sup>1</sup>		
160	HR_FORCE_PRESS_HIGH					
161	HR_RESET_MIN_MAX	Reset of all min and max	RW	0	1	0

<sup>1</sup> Maximum and minimum values according to **Table 1**.

**Table 11 –** Force and minimum and maximum registers

DEVICE TAG REGISTERS						
Address	Register	Description	Type			
166	HR_PRODUCT_TAG01	Device name string	RW	ASCII	CARACTER 2	CARACTER 1
167	HR_PRODUCT_TAG02		RW	ASCII	CARACTER 4	CARACTER 3
168	HR_PRODUCT_TAG03		RW	ASCII	CARACTER 6	CARACTER 5
169	HR_PRODUCT_TAG04		RW	ASCII	CARACTER 8	CARACTER 7
170	HR_PRODUCT_TAG05		RW	ASCII	CARACTER 10	CARACTER 9
171	HR_PRODUCT_TAG06		RW	ASCII	CARACTER 12	CARACTER 11
172	HR_PRODUCT_TAG07		RW	ASCII	CARACTER 14	CARACTER 13
173	HR_PRODUCT_TAG08		RW	ASCII	CARACTER 16	CARACTER 15
174	HR_PRODUCT_TAG09		RW	ASCII	CARACTER 18	CARACTER 17
175	HR_PRODUCT_TAG10		RW	ASCII	CARACTER 20	CARACTER 19

**Table 12 –** Device tag registers

The registers 103 to 106, 123 to 126, 157 and 158 must be used by the user to enter the values of their respective parameters. If they are within limits, the device will automatically pass these values to registers 108 to 111, 132 to 135, 159 and 160, which show the values considered during the operation. In case of extrapolation of limits, this condition will be signaled in register 343 (HR\_DIAGNOSE03).

For 32-bit data, the two registers that compose them must be read and/or written for the values to be updated.

DIAGNOSTIC REGISTERS				
Address	Register	Description	Type	Bit
341	HR_DIAGNOSE01	Unit configuration error	RO	0
		Overload detection at alarm output		1
		Forced alarm status		3
		Alarm status		5
		Alarm forcing is enabled		10
		Forcing the exit is enabled		12
342	HR_DIAGNOSE02	Differential pressure sensor error	RO	0
343	HR_DIAGNOSE03	The input of retransmission limits is out of range	RO	1
		Alarm setpoint input is out of range		3
		Pressure forcing value input is out of range		6
344	HR_DIAGNOSE04	Indicates that the lower range limit has been exceeded	RO	1
		Indicates that the upper range limit has been exceeded		2

Table 13 – Diagnostic registers

LIMIT REGISTERS					
Address	Register	Description	Type	Minimum	Maximum
359	HR_PRESS_HIGH_LIMIT	Maximum limit	RO	Depends on model and unit of measure selected <sup>1</sup>	
360	HR_PRESS_HIGH_LIMIT_H		RO		
361	HR_PRESS_LOW_LIMIT	Minimum limit	RO	Depends on model and unit of measure selected <sup>1</sup>	
362	HR_PRESS_LOW_LIMIT_H		RO		

<sup>1</sup> Maximum and minimum values according to Table 1.

Table 14 – Limit registers

## 8 SIGNOW SOFTWARE AND APP

### 8.1 SIGNOW SOFTWARE

**SigNow** software is the main tool for configuring, downloading, and analyzing data from **NP785 Ultra Low Differential Pressure Transmitter**. It allows you to use all the features of the device, communicating through the USB interface.

To install **SigNow**, just download and run the **SigNowSetup.exe** file, available on our website.

This manual describes the generic features of the software. For detailed instructions on setting up other devices and operating certain tools, you should check the specific operation manual. The software and its respective manual can be downloaded for free in the Download Area of our website [www.novusautomation.com](http://www.novusautomation.com).

### 8.2 SIGNOW APP

**SigNow** app is the ideal tool for the daily use of **NP785 Ultra Low Differential Pressure Transmitter**. It is compatible with both Android and iOS devices, making it accessible to everyone.

**SigNow** app can be downloaded for free from *Google Play Store* or *App Store*.

To configure the device through the app, you must connect it to the smartphone via an OTG cable (see [USB INTERFACE](#) chapter).

### 8.3 STARTING SIGNOW

When running **SigNow**, the following screens will appear:



Figure 9 – SigNow main screen

To communicate with the software, **NP785 Ultra Low Differential Pressure Transmitter** must be connected to the computer and have the USB drivers previously installed (see [CONNECTING TO A COMPUTER](#) section). To communicate with the app, you must connect the device to the smartphone via an OTG cable (see [CONNECTING TO A SMARTPHONE](#) chapter).

Next, you can click either **Configuration** or **Diagnostics**.

The **Create Configuration** option allows you to create a configuration. The device does not need to be connected. This configuration can be saved to a file for future use or be written to a connected device. The **Open Configuration** option, on the other hand, allows you to read an already created configuration file.

## 8.4 CONNECTING TO SIGNOW SOFTWARE

Once the **SigNow** software is running, it is possible to read a device. To do this, you must click **Configuration**, select the **USB** option, and then the connected device:



Figure 10 – Selecting a device

When you click on the **NP785 Ultra Low Differential Pressure Transmitter** icon, the software will read the current device configuration and present all available features, as shown in the figure below:

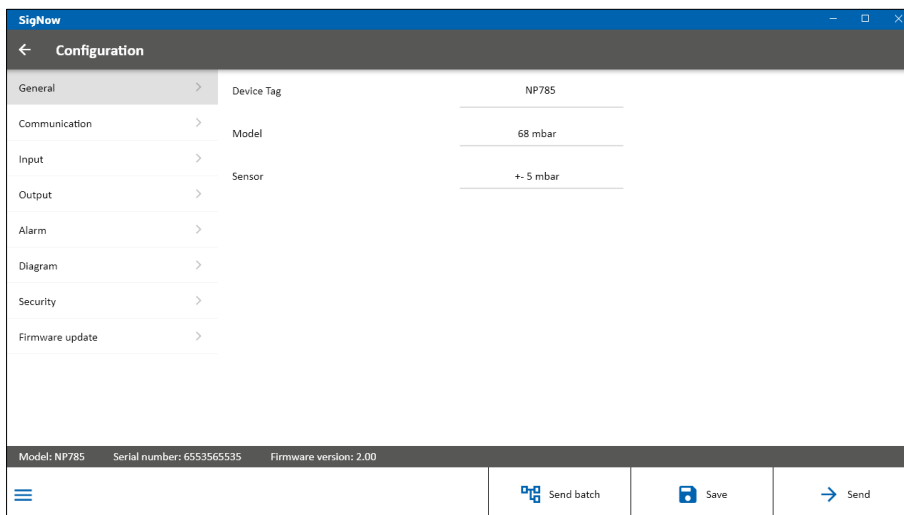



Figure 11 – Device configuration screen

The configuration screen is divided into 8 sections: **General**, **Communication**, **Input**, **Output**, **Alarm**, **Diagram**, **Security**, and **Firmware Update**. You can access these sections via side menu. The **General** screen is the first screen to appear.

The bottom part of the screen displays information about model, serial number, and firmware version, non-editable fields that are read by the software directly from the device. In addition, it displays the following buttons: , **Send Batch**, **Save**, and **Send**.

The  button compiles the following options:

- 1) **Manual:** Allows you to access the online manual for the device.
- 2) **Support:** Allows you to access the Technical Support page.
- 3) **Event Log:** Allows you to access a window that displays information about the settings made so far.
- 4) **Report:** Allows you to create a report with a .pdf extension, displaying all settings of the device.

## 8.5 CONNECTING TO SIGNOW APP

When using **SigNow** app, however, there is no need to select the device. It will be automatically recognized by the smartphone, as shown in the figure below:

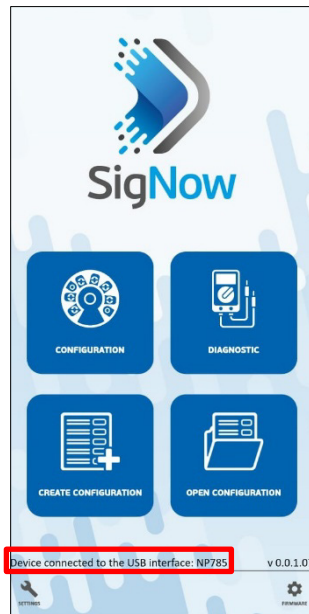



Figure 12 – Recognized device

Clicking the **Configuration** button on the home screen will take you directly to the device information screen:



Figure 13 – Information screen

This screen can be accessed at any time by clicking the **Info** button and displays information about product model and serial number, non-editable fields that are read by the app directly from the device. In addition, it displays the following buttons:  , **Home**, **Basic**, and **Advanced**.

The  button compiles the following options:

- 1) **Manual:** Allows you to access the online manual for the device.
- 2) **Support:** Allows you to access the Technical Support page.
- 3) **Save:** Allows you to save the settings made so far.
- 4) **Send:** Allows you to send the settings to the device.

## 8.6 CONFIGURING THE DEVICE

The connection mode is slightly different between software and app, but the configuration and distribution of information and parameters is the same between both.

### 8.6.1 GENERAL / BASIC

This screen allows you to view general device information. The name of the screen changes between software (called **General**) and app (called **Basic**):

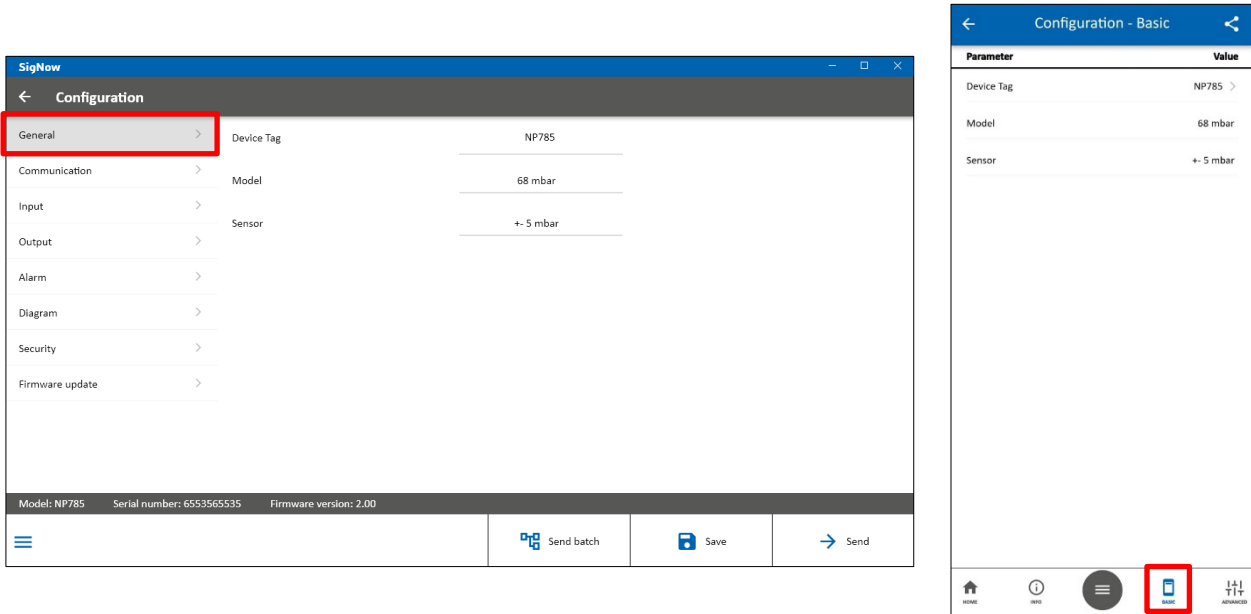

Figure 14 – General Screen

In the **Device Tag** field, you can assign a name to the device to be configured. This way, the device can be easily recognizable within a network with multiple devices.

**Model**, **Serial Number**, and **Firmware Version** are non-editable fields read by the software directly from the device.

### 8.6.2 COMMUNICATION

This screen allows you to configure the communication parameters of the device:

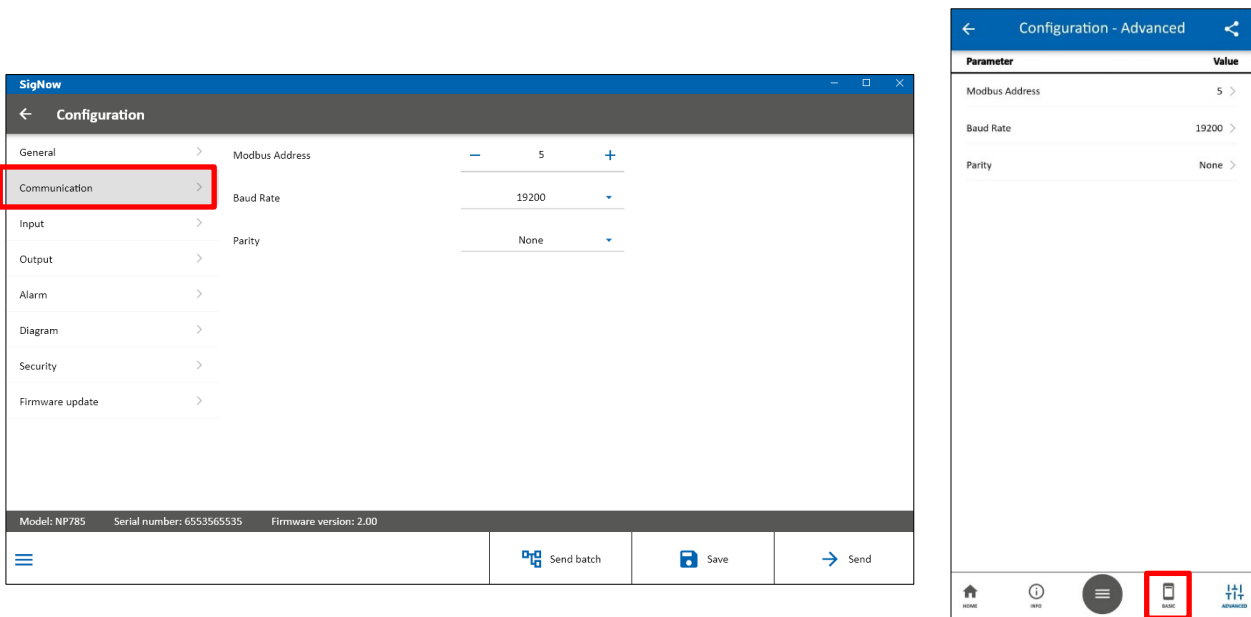

Figure 15 – Communication screen

For **NP785 Ultra Low Differential Pressure Transmitter** to be recognized as a slave device in an RS485 Modbus network, you need to set a unique **Modbus address** on the network, as well as **Baud Rate** and **Parity**.

### 8.6.3 INPUT

This screen allows you to configure the input channel of the pressure sensor:

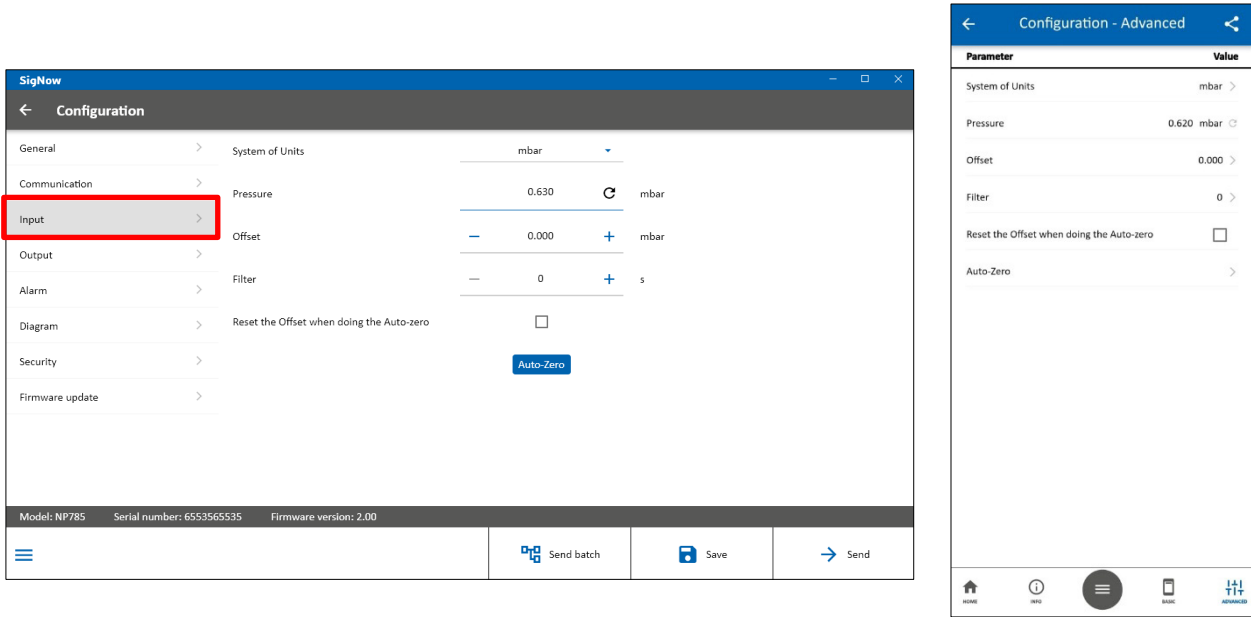



Figure 16 – Input screen

In **System of Units** parameter, you can select the following units: mbar, mpsi, inH2O, mmH2O, or pascal. By factory default, the unit of the device is set to mbar.

The **Pressure** parameter informs the differential pressure of the device when the window is opened. Click the  button allows you to update this value.

The **Differential Pressure Offset** and **Filter** parameters allow you to make small corrections to the sensor readings and change its response speed.

By clicking the  button, you can perform automatic adjustment of the Offset. To do so, it is necessary to ensure that the pressure inputs are depressurized.

By enabling the **Reset Offset when performing Auto-Zero**, the device will reset the Offset whenever it performs the Auto-Zero function. If this option is disabled, the device will correct the sensor reading error, keeping the configured Offset value.

If the pressure read by the sensor is 0, for example, and the Offset has been set to 2, using the **Auto-Zero** function without resetting the Offset means that the output will stay at 2. If you select the option to reset the Offset, the output will be 0.

### 8.6.4 OUTPUT

This screen allows you to configure the analog output of the device:

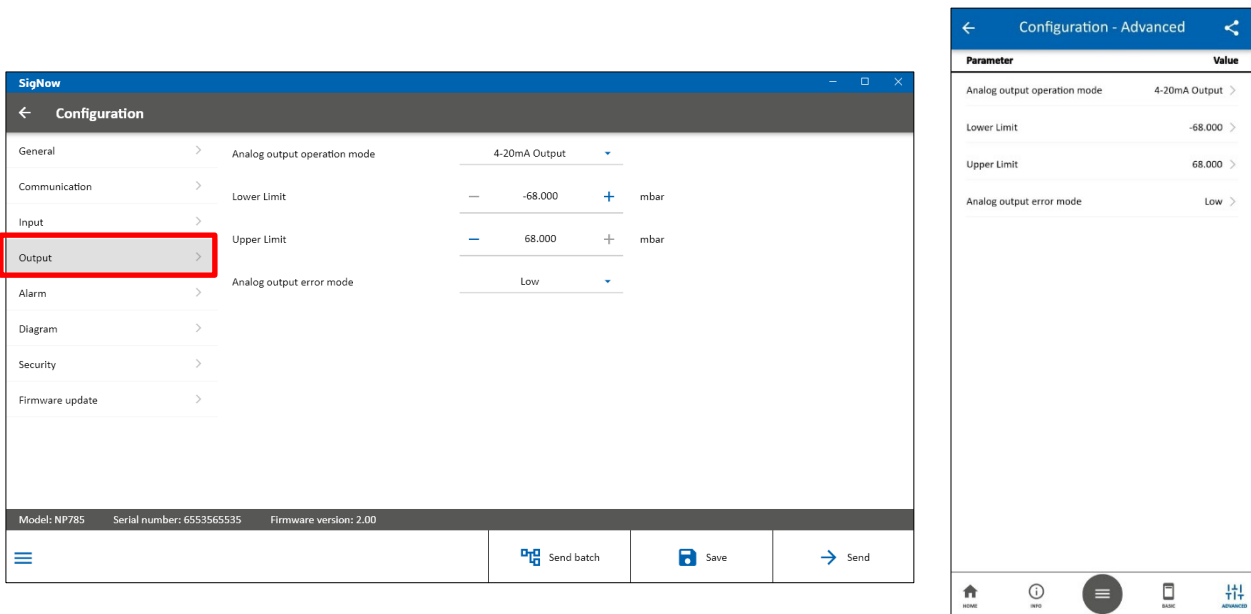

Figure 17 – Alarm screen

The **Analog output operation mode** function allows you to select the electrical standard to be used for transmission: 0-10 V or 4-20 mA. The electrical output signal will be proportional to the selected quantity, respecting the values set in the parameters **Lower Limit** and **Upper Limit**. In case of a sensor failure, the quantity to be transmitted by the analog output will go into error mode. For the error condition, you must select the **High, Low, or Low-High** status (see **Table 4**).

### 8.6.5 ALARM

This screen allows you to configure the alarm output of the device:

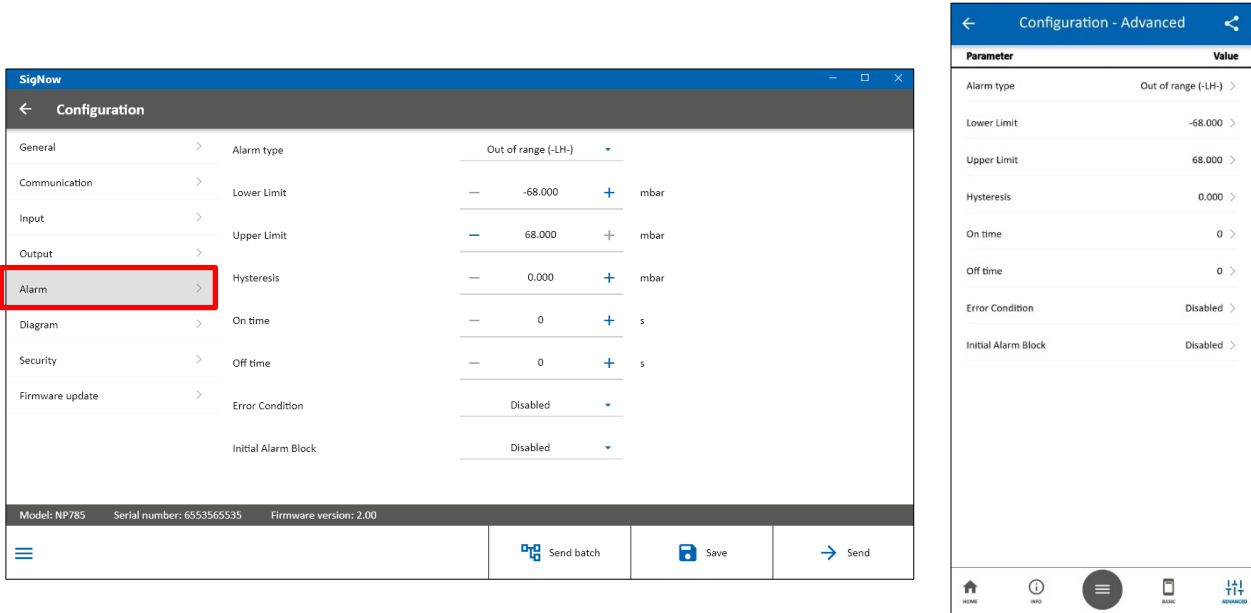

Figure 18 – Alarm screen

The alarm output can be timed using the parameters **On Time** and **Off Time**.

If the device is configured in **Value Below SPLo, Value Above SPHi, Within Range** or **Out of Range** modes, the **Error Condition** parameter allows you to configure a safe status of the alarm output in case of sensor failure. Therefore, the output will be turned on or off according to the value set in these parameters.

The **Upper Limit** and **Lower Limit** are the differential pressure values that act as alarm activation conditions that, with the **Hysteresis**, define the barrier to be passed for the channel to leave the alarm situation. For more information about the alarm configuration, see [ALARM SETTINGS](#) section.

### 8.6.6 DIAGRAM

This screen shows information about the basic electrical connections and the dimension of the device:

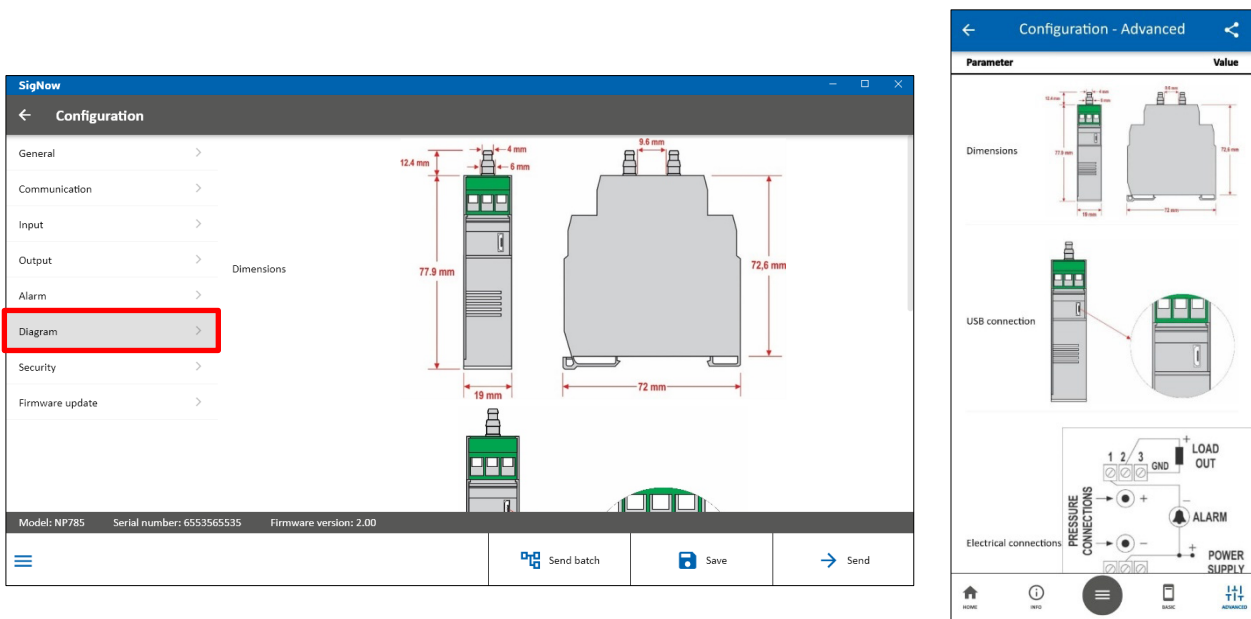

Figure 19 – Diagram screen

## 8.6.7 SECURITY

This screen allows you to configure a password to protect the configuration:

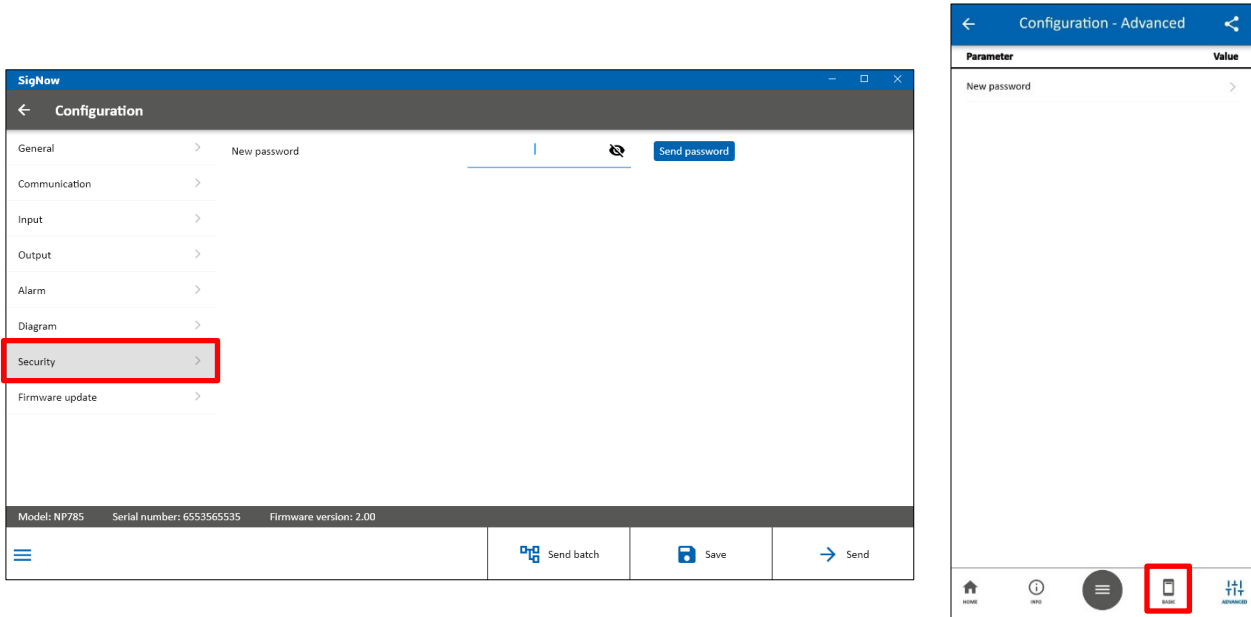

Figure 20 – Security screen

You can set a password with 4 numbers. Once it has been sent to the device via **Send password** button, the software will request it whenever a new configuration needs to be sent.

Once a password is set, you can remove it by simply emptying the **New Password** parameter field and clicking the **Send password** button again.

## 8.6.8 FIRMWARE UPDATE

This screen allows you to update the firmware of the device:

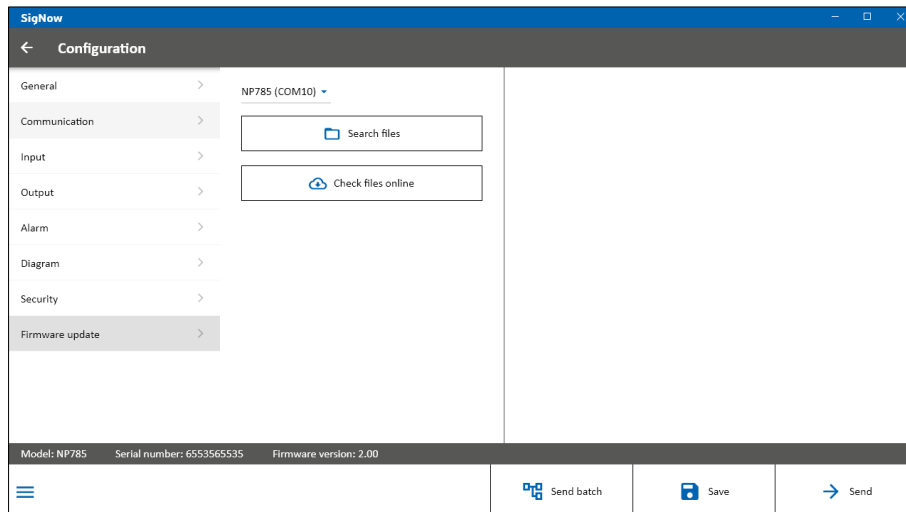

Figure 21 – Firmware update screen

The firmware update process is standard for all **NOVUS** devices linked to **SigNow** and can be viewed in detail in the software manual.

To update the firmware through the app, however, you must click on the **Firmware** button, located on the start screen, and then proceed in the same way, searching for the desired file or checking online for its existence.



Figure 22 – Upgrading firmware via app

## 8.7 PERFORMING DIAGNOSTICS

From the **SigNow** home screen, you can access the **Diagnostic** screen and monitor some device status. The information update interval is 1 second.

To access it, you must click **Diagnostic**, select the **USB** option, and then the connected device:

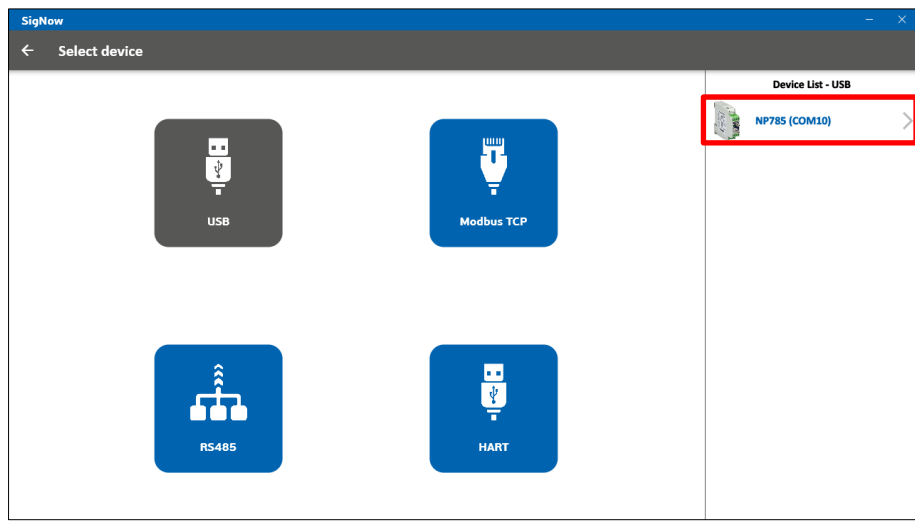

Figure 23 – Selecting a device

Since the app performs device recognition from the first moment of connection, the above process should be disregarded if you are using **SigNow** app.

Then both software and app will read the current device configuration and present all available features, as shown in the figure below:

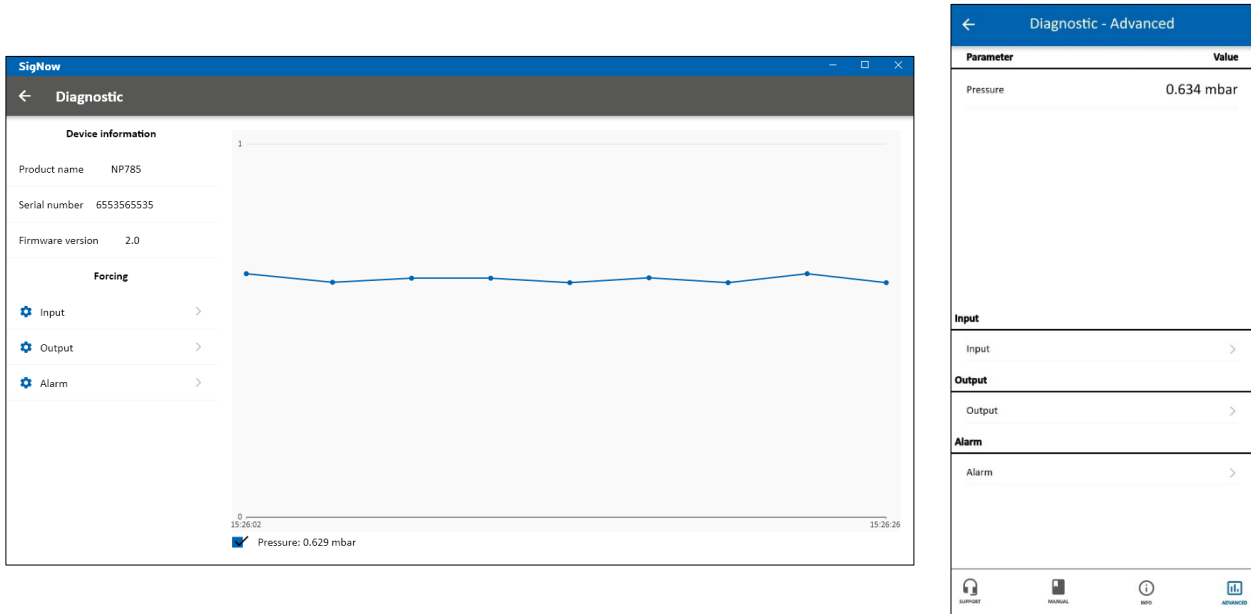



Figure 24 – Device diagnostic screen

Thus, it is possible to analyze the operation of the device when forcing pressure readings. To force a value, you must type the desired value in the parameter's field or use the  $-$  or  $+$  keys to reach the desired value. After that, press  button.

In the **Input Diagnostic** screen, you can view the current value of the differential pressure or force a certain value.

In the **Input Diagnostic** screen, you can view the current value of the analog output or force a certain value. This interface depends on the type of analog output configured (0-10 V or 4-20 mA) and will be set automatically.

You can also force an error value to be transmitted by checking the **Min. Error.** and **Max. Error.** These values depend on the mode (0-10 V or 4-20 mA) configured for each output.

In the **Alarm Diagnostic** screen, you can force the following conditions: **1) Off**, if none of the options are checked; **2) Forced-On**, if the **Turns On** option is checked; or **3) Forced-Off**, if the **Turns Off** option is checked.

## 9 TECHNICAL SPECIFICATION

	NP785-50PA MODEL	NP785-100PA MODEL	NP785-05 MODEL	NP785-20 MODEL	NP785-68 MODEL	NP785-400 MODEL	NP785-1000 MODEL
Measurement Range	-50 to 50 Pa	-100 to 100 Pa	-5 to 5 mbar	-20 to 20 mbar	-68 to 68 mbar	-400 to 400 mbar	-1000 to 1000 mbar
Proof Pressure*	68 mbar	68 mbar	100 mbar	300 mbar	136 mbar	800 mbar	2000 mbar
Burst Pressure	200 mbar	200 mbar	200 mbar	400 mbar	2000 mbar	4000 mbar	4000 mbar
Line Pressure**	68 mbar	68 mbar	100 mbar	300 mbar	136 mbar	800 mbar	2000 mbar
Accuracy (RSS, includes linearity, hysteresis, and repeatability)	1.5 % of maximum range F.S.***	1 % of maximum range F.S.	1 % of maximum range F.S.	0.5 % of maximum range F.S.	1 % of maximum range F.S.	0.5 % of maximum range F.S.	0.5 % of maximum range F.S.
Total error (RSS, includes linearity, hysteresis, repeatability, and temperature variation)	< ± 3.1 % of maximum range F.S.	< ± 1.6 % of maximum range F.S.	< ± 1.5 % of maximum range F.S.	< ± 1 % of maximum range F.S.	< ± 2 % of maximum range F.S.	< ± 1 % of maximum range F.S.	< ± 1 % of maximum range F.S.
Mounting Position Influence	< ± 0.03 % of maximum range. Can be corrected by adjusting the zero.						
Supply Voltage Influence	< 0.001 % F.S. / V						
Zero Setting	± 10 % of maximum range. Can be done through software, app or Auto-Zero key.						
Effective Sensor Resolution	0.005 % F.S.	0.002 % F.S.	0.008 % F.S.	0.008 % F.S.	0.032 % F.S.	0.013 % F.S.	0.01 % F.S.
	14.4 bits	15.4 bits	13.6 bits	13.6 bits	11.6 bits	12.9 bits	13.4 bits
Digital reading resolution****	8.6 bits	9.6 bits	12 bits	13.6 bits	11.6 bits	12.9 bits	13.4 bits
Start-Up Time	< 2 s						
Measurement Update Time	< 15 ms****		< 50 ms****			< 15 ms****	
Response Time for the RS485	< 41ms, reading 125 registers at 115200 bps.						
Response Time for the analog output (0 – 95%)	< 55 ms****		< 90 ms****			< 55 ms****	
Digital Filter	Configurable via software or app. From 0 to 300s.						
Operation Temperature	-20 to 70 °C (-4 to 158 °F)		-5 to 65 °C (23 to 149 °F)		-20 to 70 °C (-4 to 158 °F)		
Storage Temperature	-20 to 85 °C (-4 to 185 °F)						
Alarm Output	<ul style="list-style-type: none"> <li>Channel N 30 V / 200 mA type output.</li> <li>Protection against overcurrent &gt; 200 mA.</li> <li>Overcurrent protection reset time: 5 seconds.</li> </ul>						
Power Supply Voltage	<ul style="list-style-type: none"> <li>Power supply through PWR terminals: 12 Vdc to 30 Vdc.</li> <li>Power supply through the USB cable: 4.75 Vdc to 5.25 Vdc.</li> </ul> Internal protection against power supply voltage polarity inversion.						
Supply Current	< 45 mA ± 10 % @ 24 Vdc						
Input	2 inputs for connecting 4 or 6 mm internal diameter pneumatic hose.						
Output	It can be independently configured to operate with 0-10 V or 4-20 mA signals. <ul style="list-style-type: none"> <li>0-10 V:               <ul style="list-style-type: none"> <li>Maximum current: 2 mA.</li> <li>Resolution: 0.003 V.</li> </ul> </li> <li>4-20 mA:               <ul style="list-style-type: none"> <li>Maximum Load: 500 R.</li> <li>Resolution: 0.006 mA.</li> </ul> </li> </ul>						
Protection Index	IP20						
Wetted Parts	Materials include silicone, glass, RTV, gold, aluminum, copper, nickel, palladium, epoxy, stainless steel, and plastic.						
Housing	ABS + PC						
Electromagnetic Compatibility	EN/IEC 61326-1						
Configurator Software	<ul style="list-style-type: none"> <li>SigNow software, compatible with Windows 10 or higher.</li> <li>SigNow app, compatible with Android and iOS smartphones.</li> </ul>						
Certifications	<b>CE Mark / UKCA</b> This is a Class A product. In a domestic environment, this product may cause radio interference in which case the user may be required to take						

adequate measures.
--------------------

\* **Proof Pressure:** The maximum pressure that the device can be subjected to and still perform within specifications after returning to operating range.

\*\* **Line pressure:** The maximum pressure that can be applied simultaneously to both pressure ports of the sensor without causing permanent damage and without applying differential pressure.

\*\*\* **Full Scale (F.S.):** Under reference conditions: Ambient  $23\text{ }^{\circ}\text{C} \pm 3^{\circ}\text{C}$ , 24 V supply,  $250\ \Omega$  load. Vertical mounting. Line pressure: 0 mbar when applying Auto-Zero.

\*\*\*\* With 0s filter.

\*\*\*\*\* The resolution shown corresponds to the digital values read from registers 0 to 5 and is lower than the sensor resolution due to the limitation of decimal places. The digital values read from registers 6 to 11 have the same resolution as the sensor.

**Table 15 –** Technical specifications

## 10 WARRANTY

Warranty conditions are available on our website [www.novusautomation.com/warranty](http://www.novusautomation.com/warranty).